

# All-India Survey of Photovoltaic Module Degradation: 2013



**National Centre for Photovoltaic Research and Education  
(NCPRE), IIT Bombay**

**&**

**Solar Energy Centre, Gurgaon**

**May-June 2013**



# All-India Survey of Photovoltaic Module Degradation: 2013

Rajiv Dubey, Shashwata Chattopadhyay, Vivek Kuthanazhi,  
Jim Joseph John, B. M. Arora, Anil Kottantharayil, K. L. Narasimhan,  
Chetan S. Solanki, Vaman Kuber and Juzer Vasi

*National Centre for Photovoltaic Research and Education  
Indian Institute of Technology Bombay  
Powai, Mumbai 400076, India*

and

Arun Kumar and O. S. Sastry

*Solar Energy Centre  
National Institute of Solar Energy  
Gwalpahari, Gurgaon, Haryana 122003, India*

May-June 2013  
Report dated March 2014



## Acknowledgements

---

The suggestion for a survey of old PV modules in different zones in India to assess field degradation came up at a meeting of the “High Powered Task Force under JNNSM for Solar Photovoltaics”. It was agreed that the National Centre for Photovoltaic Research and Education (NCPRE) at IIT Bombay, together with Solar Energy Centre (SEC), Gurgaon could undertake this survey. NCPRE and SEC would like to thank the various participants in the survey at various levels (PV system owners, state Renewable Energy nodal agencies, private EPC contractors and local installers) who have helped us in multiple ways to bring the survey to fruition. These include Dr. Bibek Bandyopadhyay in SEC; Dr. S. P. Gon Chaudhuri, Mr. P. K. Chandra and Prof. Susanta Sen in West Bengal; Dr. K. M. Dhariesan, Shri. T. P. Sadananda Pai, Mr. M. P. Antoni and Mr Aji Augustine, in Kochi (Kerala); Mr. Hemant Lamba in Auroville; Mr. Bunker Roy, Mr. Bhagwat Nandan and Mr. Satyanarayana in Tilonia (Rajasthan); Mr. Gaurav Kumar in Patna; Prof. B.S. Acharya, Prof. T.P. Prabhu and Mr. Dorje Angchuk in Hanle (Ladakh); Prof. M. Kumaravel in IIT Madras; Mr. Sandeep Sonigra in Pune; and Mr. Prakash Suratkar in Bangalore.

Special mention may be made of the hospitality received from the Indian Institute of Astrophysics for allowing us to visit the highest astronomical observatory in the country at Hanle, situated very close to the Chinese border, which necessitated special permissions from the Indian Army. We are especially thankful also to Mr. Hemant Lamba who initiated this survey through his suggestion at the Task Force meeting, as well as to him and Dr. S. P. Gon Chaudhuri for giving much support in organizing the survey. Mr. Lamba and Dr. Gon Chaudhuri as well as Dr. Rajesh Kumar of SEC also provided valuable comments on the results. We are also thankful to Dr. Sarah Kurtz and Dr. Dirk Jordan of National Renewable Energy Laboratories of USA for their insights into statistical analysis of the survey data. Finally, NCPRE would like to thank the Ministry of New and Renewable Energy (MNRE) for funding which enabled this survey to be undertaken.



# Contents

---

<b>Executive Summary</b>	<b>xvii</b>
<b>Chapters</b>	
<b>1. Introduction</b>	<b>1</b>
1.1 Introduction to the Survey	
1.2 Structure of the report	
<b>2. Literature Review</b>	<b>3</b>
2.1 Introduction	
2.2 Review of PV Survey Methodologies	
2.3 Performance of different PV Module Technologies	
2.3.1 Electrical Performance	
2.3.2 Module Component degradation	
2.4 Socio-economic aspects	
2.5 Conclusion	
<b>3. Survey Methodology</b>	<b>19</b>
3.1 Introduction	
3.2 Equipment Specifications	
3.3 Survey Checklist	
3.4 Precautions	
3.5 Conclusion	
<b>4. Climatic Zones of India</b>	<b>23</b>
4.1 Introduction	
4.2 Climatic zone classification criteria	
4.3 Sites surveyed in different climatic zones	
4.4 Conclusion	
<b>5. Analysis and Corrections applied to Survey Data</b>	<b>27</b>
5.1 Introduction	
5.2 IEC 60891-1 correction procedures	

- 5.2.1 Correction procedure 1
- 5.2.2 Correction procedure 2
- 5.2.3 Correction procedure 3
- 5.3 Correction Procedure adopted for survey data
  - 5.3.1 Correction Procedure 1a
  - 5.3.2 Low irradiance correction
- 5.4 Software package for STC correction
- 5.5 Choice of using the Median versus the Mean
- 5.6 Uncertainties in Degradation rate calculation
  - 5.6.1 Uncertainties in Measurements
  - 5.6.2 Uncertainties in Correction Procedure
  - 5.6.3 Uncertainties in power at STC
- 5.7 Conclusions

**6. Information on Modules Surveyed 43**

- 6.1 Introduction
- 6.2 Sites Surveyed
- 6.3 Histograms of Module Details
- 6.4 Conclusions

**7. Analysis of Electrical Degradation 57**

- 7.1 Introduction
- 7.2 Performance Degradation in crystalline Silicone modules
  - 7.2.1 Degradation in Power output
  - 7.2.2 Degradation in Maximum Power Point Parameters ( $P_{max}$ ,  $I_{max}$ ,  $V_{max}$ )
  - 7.2.3 Degradation in I-V curve parameters ( $I_{sc}$ ,  $V_{oc}$ ,  $FF$ )
  - 7.2.4 Correlation between  $P_{max}$  & I-V curve parameters' degradation
  - 7.2.5 Performance degradation of similar modules in different climatic zones
- 7.3 Performance Degradation in Thin film Modules
  - 7.3.1 Degradation in Power
  - 7.3.2 Degradation in I-V parameters
- 7.4 Conclusions

<b>8. Analysis of Visual Degradation</b>	<b>75</b>
8.1. Introduction	
8.2. Visual Degradation Modes observed in crystalline silicon modules	
8.2.1. Discoloration of Encapsulant	
8.2.2. Front-side Delamination of Encapsulant	
8.2.3. Corrosion of metallization, Interconnects & Output terminals	
8.2.4. Bubbles & Delamination in backsheet	
8.2.5. Chalking (white powder) from backsheet	
8.2.6. Junction Box Damage	
8.2.7. Frame Damage	
8.3. Visual Degradation Modes observed in thin film modules	
8.4. Correlation of Visual degradation with electrical degradation	
8.4.1. Discoloration of Encapsulant	
8.4.2. Corrosion in the Metallization, Interconnects and Terminals	
8.4.3. Delamination	
8.5. Champion Modules	
8.6. Conclusions	
<b>9. Socio-Economic Perspective</b>	<b>121</b>
9.1. Introduction	
9.2. Framework for Analysis: Categorization of Surveyed PV Installations	
9.2.1. Categorization based on type of ownership	
9.2.2. Categorization based on financial models	
9.2.3. Categorization based on End Purpose of Installation	
9.3. Parameters for analysing appropriateness in installation: Location and accessibility, support structure, shading, tilt angle and orientation	
9.4. Parameters for analysing appropriateness of system maintenance: Module cleaning, maintenance and skill level of technicians	
9.5. Linkages between ownership, financial model and purpose of the installation with appropriateness in installation and maintenance of systems	
9.6. Conclusions	
<b>10. Future Work</b>	<b>141</b>

<b>11. Conclusions &amp; Recommendations</b>	<b>143</b>
11.1. Overall Summary	
11.2. Key Observations and Conclusions	
11.3. Surprise Findings	
11.4. Recommendations	
<b>References</b>	<b>149</b>
<b>List of Appendices</b>	
Appendix I Survey Checklist	155
Appendix II Software package for STC correction	170
Appendix III Site-wise Analysis	175

# List of Figures

---

Fig. 3.1	Schematic of the I-V Tracer, showing the Temperature sensor and the Irradiance meter.	21
Fig. 3.2	EasIR-4 Infrared Camera	21
Fig. 4.1	Climatic Zones of India (Sites covered in the Survey have been marked in red)	25
Fig. 5.1	Irradiance and Temperature Correction	31
Fig. 5.2	Error in $P_{max}$ at different irradiances for Mono c-Si	33
Fig. 5.3	Error in $P_{max}$ at different irradiances for Multi c-Si	34
Fig. 5.4	Error in $P_{max}$ at different irradiances for a-Si	34
Fig. 5.5	Error in $P_{max}$ at different irradiances for CIGS	35
Fig. 5.6	Correlation between percentage changes in $P_{max}$ vs. sum of percentage change in $V_{oc}$ , $I_{sc}$ and $FF$	37
Fig. 5.7	Degradation rates of IV parameters showing both the Median and Mean values	38
Fig. 5.8	Major influences on the combined uncertainty of power at STC	38
Fig. 5.9	Percentage Error in $P_{max}$ at STC vs. temperature.	40
Fig. 5.10	The contributors to the combined uncertainty of power at STC	40
Fig. 6.1	Technology-wise distribution of inspected modules	51
Fig. 6.2	Age-wise distribution of inspected modules	52
Fig. 6.3	Rated Power distribution of inspected modules	52
Fig. 6.4	Climatic zone-wise distribution of the modules	53
Fig. 6.5	Type of Biasing of the inspected modules	53

Fig. 6.6	Packaging material distribution of inspected modules	54
Fig. 6.7	Balance of System configuration	54
Fig. 6.8	Extent of soiling	55
Fig. 7.1	Histogram of degradation rate with extreme value fit	59
Fig. 7.2	$P_{max}$ degradation per year for mono and multi crystalline modules	59
Fig. 7.3	Comparison of $P_{max}$ value in different climatic zone.	60
Fig. 7.4	Annual degradation rate for $P_{max}$ , $I_{max}$ and $V_{max}$ for mono c-Si	61
Fig. 7.5	Annual degradation rate for $P_{max}$ , $I_{max}$ and $V_{max}$ for multi c-Si	61
Fig. 7.6	Maximum power point parameter degradation distribution for (a) Hot & Humid Climatic Zone (b) Hot & Dry Zone (c) Temperate Zone (d) Cold Zone and (e) Composite Zone	62
Fig. 7.7	$P_{max}$ , $I_{sc}$ , $V_{oc}$ and $FF$ degradation for mono c-Si	63
Fig. 7.8	$P_{max}$ , $I_{sc}$ , $V_{oc}$ and $FF$ degradation for multi c-Si	64
Fig. 7.9	I-V parameter degradation distribution for (a) Hot & Humid climatic zone (b) Hot & Dry climatic zone (c) Temperate zone (d) Cold climatic zone and (e) Composite zone	65
Fig. 7.10	Correlation of $P_{max}$ with $I_{sc}$ degradation for Hot and Humid climatic zone and non-Hot & Humid climatic zones	67
Fig. 7.11	Correlation of $P_{max}$ with $V_{oc}$ degradation for Hot and Humid climatic zone and non-Hot & Humid climatic zones	68
Fig. 7.12	Correlation of $P_{max}$ with $FF$ degradation for Hot & Humid climatic zone and non-Hot & Humid climatic zone	68
Fig. 7.13	Comparison of $P_{max}$ in different climatic conditions	69
Fig. 7.14	Comparison of $I_{sc}$ and $V_{oc}$ and $FF$ in different climatic conditions	69
Fig. 7.15	$P_{max}$ degradation rate for different thin film technologies	71

Fig. 7.16	$P_{max}$ , $I_{sc}$ , $V_{oc}$ and $FF$ degradation for thin film technology	73
Fig. 8.1	Structure of a typical crystalline silicon PV module	75
Fig. 8.2	Module having dark discoloration on solar cells	77
Fig. 8.3	Discoloration in modules in the respective climatic zones and age groups.	79
Fig. 8.4	Percentage of surveyed modules that had encapsulant discoloration (light or dark) in the respective climatic zone & age group.	80
Fig. 8.5	Modules of different manufacturers installed at Hanle 15 years ago	81
Fig. 8.6	28 year old PV module (glass on both top & bottom) showing no discoloration of the encapsulant	82
Fig. 8.7	Browning of EVA from the centre with transparent EVA intact at the edge of the solar cell	83
Fig. 8.8	Uneven discoloration (left) in a module and puncture in the back-sheet (right) of same module.	83
Fig. 8.9	Cracks in a solar cell are made visible by the photo-oxidative bleaching effect on the otherwise discolored EVA.	84
Fig. 8.10	Delamination (seen as light blue region in the bottom left-most solar cell) of a module (top image) installed in Composite zone in 1999 and its infra-red image (bottom image)	85
Fig. 8.11	Delamination (light blue region seen along the edges of the solar cell and criss-crossing the centre of the solar cell) in a PV module installed in Hot & Dry climate in 2000.	85
Fig. 8.12	Delamination (bubbles) in a PV module installed in Hot & Dry climate in 1988	86
Fig. 8.13	Front-side delamination in modules in the respective climatic zones and Age groups.	87

Fig. 8.14	Percentage of surveyed modules that have front-side delamination in the respective climatic zone & age group.	88
Fig. 8.15	Corrosion (discoloration) in fingers	89
Fig. 8.16	Corrosion & burn marks on busbars & interconnects	90
Fig. 8.17	Corrosion (seen as red, green & black discoloration) in the string interconnect of a PV module installed in Hot & Dry zone in 1988.	90
Fig. 8.18	Corrosion in output terminals	90
Fig. 8.19	Front-side delamination in modules in the respective Climatic Zones and Age groups.	92
Fig. 8.20	Percentage of surveyed modules that have suffered corrosion in the respective climatic zone & age group.	93
Fig. 8.21	Bubble in backsheet of a module (encircled in red dots)	94
Fig. 8.22	Bubbles and delamination in module backsheet in the respective climatic zones and age groups.	95
Fig. 8.23	Percentage of surveyed modules that have backsheet delamination and bubbles in the respective climatic zone and age group.	96
Fig. 8.24	White powder from backsheet of a module	97
Fig. 8.25	Chalking in Module Backsheet in the respective climatic zones and age groups.	98
Fig. 8.26	Percentage of surveyed modules that have backsheet delamination & bubbles in the respective climatic zone & age group	99
Fig. 8.27	Junction box with no sealing, which has lead to corrosion of output terminals and Bypass Diodes	100
Fig. 8.28	Junction box with good sealing, which has prevented corrosion of output terminals and Bypass Diodes	100
Fig. 8.29	Condition of Junction Box structure	101

Fig. 8.30	Condition of Junction Box Attachment & sealing	101
Fig. 8.31	Corroded and dented frame of a PV module	102
Fig. 8.32	Corrosion (blackening) of the frame of a PV module	102
Fig. 8.33	Condition of frame and frame grounding connection	103
Fig. 8.34	Light yellow discoloration seen in CIGS module	104
Fig. 8.35	13 years old CIGS Module installed in Composite climate	105
Fig. 8.36	Dark patches close to electrode of CIGS module	105
Fig. 8.37	Puncture in the backsheet of the CIGS module	106
Fig. 8.38	White deposits (salts) at the edges of the CIGS Module	106
Fig. 8.39	Bar-graph corrosion in amorphous silicon double tandem PV modules	107
Fig. 8.40	Cracks in the glass of the corroded module	108
Fig. 8.41	Corroded portion of the module (image from backside)	108
Fig. 8.42	Infra-red image (left side) of the corroded module shows that the corroded portion (blue patch near the bottom) is the coldest in the module.	109
Fig. 8.43:	Triple tandem amorphous silicon module with “snail trails”	109
Fig. 8.44	IR image of the module showing that the snail trail is operating at higher temperature than the adjoining areas.	110
Fig. 8.45	Puncture marks on the module top fabric	110
Fig. 8.46	2-month old amorphous silicon triple tandem module	111
Fig. 8.47	Damaged surface of the triple tandem a-Si module	111
Fig. 8.48	Correlation between $I_{sc}$ degradation and discoloration of encapsulant	113
Fig. 8.49	Calculation of Series Resistance from PV module I-V curve	114

Fig. 8.50	Relation between corrosion and series resistance	115
Fig. 8.51	Effect of delamination on degradation of Open circuit voltage	116
Fig. 8.52	Effect of delamination on degradation of Short circuit current	116
Fig. 8.53	(a) 7 years old PV Module (placed in Hot & Humid climate) showing no degradation in $P_{max}$ , (b) 15 years old PV Module (placed in Hot & Humid zone) with shattered front glass having $P_{max}$ degradation rate of 0.05% per year, (c) 15 years old PV Module (placed in Cold climate) having degradation rate of $P_{max}$ degradation of 0.12% per year	117
Fig. 9.1	Ease in accessing the module installation location	124
Fig. 9.2	Shading of Modules	125
Fig. 9.3	Causes for shading of modules	125
Fig. 9.4	Shading of PV modules based on ownership category	126
Fig. 9.5	Comparison of degradation rates of shaded and un-shaded modules	127
Fig. 9.6	Optimisation of tilt angle of the modules	127
Fig. 9.7	Optimisation of tilt angle and orientation	128
Fig. 9.8	Provision for proper support structure for modules	129
Fig. 9.9	Comparison of scores for appropriateness of PV installations categorised based on ownership	130
Fig. 9.10	Comparison of cleaning cycles of PV installations categorized based on ownership	132
Fig. 9.11	Effect of soiling on $P_{max}$ degradation	132
Fig. 9.12	Infra-red Image of a set of soiled and cleaned modules.	133
Fig. 9.13	Infra-red Image (a) cleaned module and (b) soiled module	133
Fig. 9.14	Effect of cleaning interval on $P_{max}$ degradation	133

Fig. 9.15	Comparison of the type of maintenance by different PV system owner categories	134
Fig. 9.16	Effect of type of Maintenance on $P_{max}$ degradation rate	134
Fig. 9.17	Comparison of the time duration between two successive maintenance services among different ownership categories	135
Fig. 9.18	Effect of Maintenance Interval on $P_{max}$ degradation rate	136
Fig. 9.19	Comparison of the skill level of technicians doing the maintenance activities of systems of different ownership categories	137



# List of Tables

---

Table 2.1	Degradation rates of maximum power output at different climatic regions for mono-crystalline and multi-crystalline silicon PV modules	8
Table 4.1	Climatic Zone Classification criteria as per Bansal <i>et al.</i>	24
Table 4.2	Latest Climatic Zone Classification criteria	24
Table 4.3	Survey site statistics	25
Table 5.1	Comparison of $P_{max}$ , obtained by Procedure 1a and measured in Solar Simulator	32
Table 5.2	Maximum Error in $P_{max}$ Translation using Procedure 1a	35
Table 5.3	Maximum Percentage Error in corrected $P_{max}$ at STC for measured irradiance greater than 550 W/m <sup>2</sup> and temperature less than 65 °C	41
Table 5.4	Maximum Percentage Error in corrected $P_{max}$ at STC for measured irradiance greater than 800 W/m <sup>2</sup> and temperature less than 65 °C	41
Table 6.1	Description of the 26 sites surveyed	44
Table 7.1	I-V Parameter Degradation by Climatic Zone	66
Table 7.2	$P_{max}$ value of a-Si with and without bar graph corrosion	71
Table 7.3	Fill Factor value of a-Si with and without bar graph corrosion	72
Table 7.4	$P_{max}$ degradation (%/year) for several Thin Film Modules	72
Table 8.1	Percentage of modules affected with different visual degradations	77
Table 8.2	Percentage of modules effected by discoloration of encapsulant in various climatic zones	78
Table 8.3	Percentage of modules effected by front-side delamination in various climatic zones	86
Table 8.4	Percentage of modules effected by corrosion in various climatic zones	91
Table 8.5	Percentage of modules effected by bubbles & delamination in	94

ALL INDIA SURVEY OF PV MODULE DEGRADATION: 2013

backsheet in various climatic zones

Table 8.6	Percentage of modules having powder on backsheet in various climatic zones	97
Table 9.1	Ownership - finance model matrix	123
Table 9.2	Ownership – End purpose matrix	124

# Executive Summary

---

## 1. Background

The All-India survey of 2013 on PV module degradation was conducted with the objective of assessing the degradation of PV modules installed in India between 3 to 30 years ago. As suggested by the “High Powered Task Force under JNNSM for Solar Photovoltaics” in its meeting held on March 4, 2013, such a survey would give valuable data on how existing installations in India have fared over the past decades, and thus give insight into the path forward for JNNSM. The National Centre for Photovoltaic Research and Education (NCPRE) set up at the Indian Institute of Technology Bombay (IITB) by MNRE was requested to undertake this survey, together with Solar Energy Centre (SEC). Accordingly, the survey was initiated in May 2013, encompassing PV modules of different ages and technologies, located in five different climatic zones in India. In the survey, a total of 63 PV modules, spread across 26 different sites (shown in Fig. I) have been thoroughly inspected. Since the aim was to assess degradation, special attention was given to modules which showed visible signs of degradation. The assessment included visual inspection, measurement of electrical parameters, weather conditions, and what we call “socio-economic” aspects. The electrical data collected for 5 PV modules in Patna (Bihar) had to be discarded owing to low irradiation levels due to rain, so the electrical analysis was performed on the data of 58 PV modules (52 crystalline silicon modules and 6 thin film modules). The technology-wise and age-wise distribution of the inspected modules are shown in Figs. II and III respectively. As expected, due to the age of the modules, many of them were of mono-crystalline silicon, and there were none of newer technologies like Cadmium Telluride (CdTe). Further, although most of the modules were between 5 to 20 years old, there were a few less than 5 years old, and some more than 20 years old.

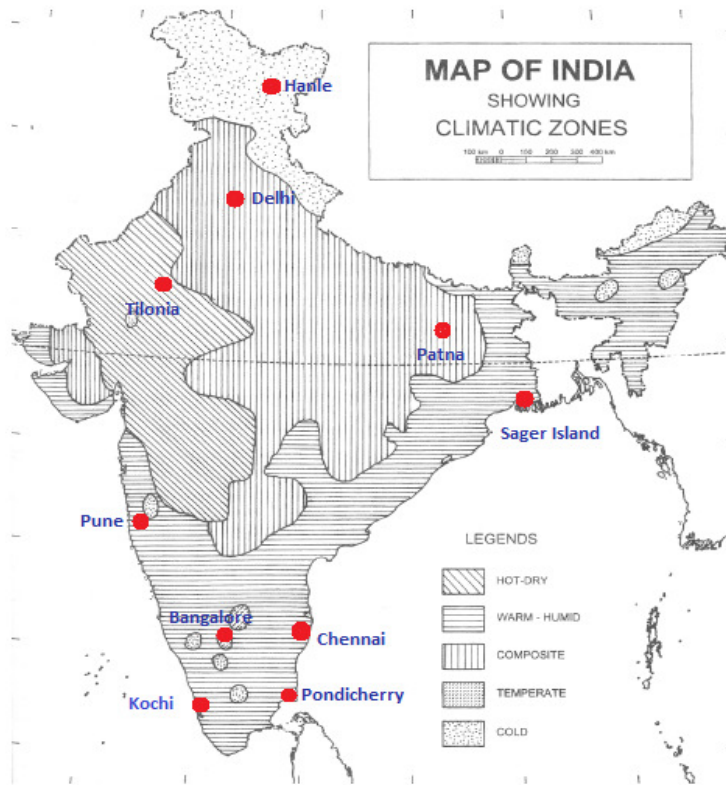

Fig. I: Outline map of India showing the various inspection sites (marked in red) in five different climatic zones [1]

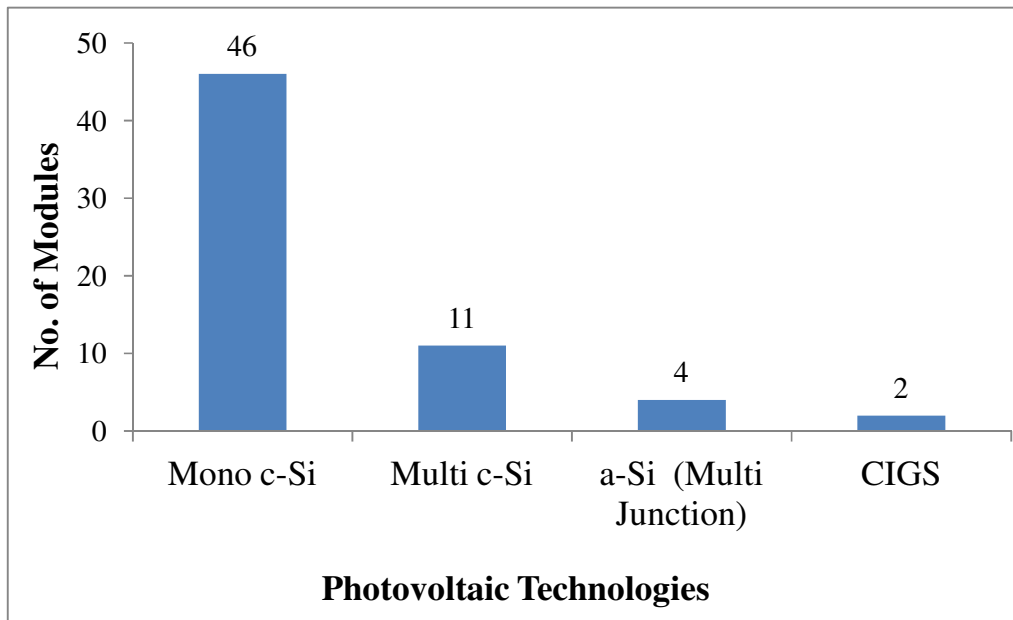

Fig. II: Technology-wise distribution of the inspected PV Modules

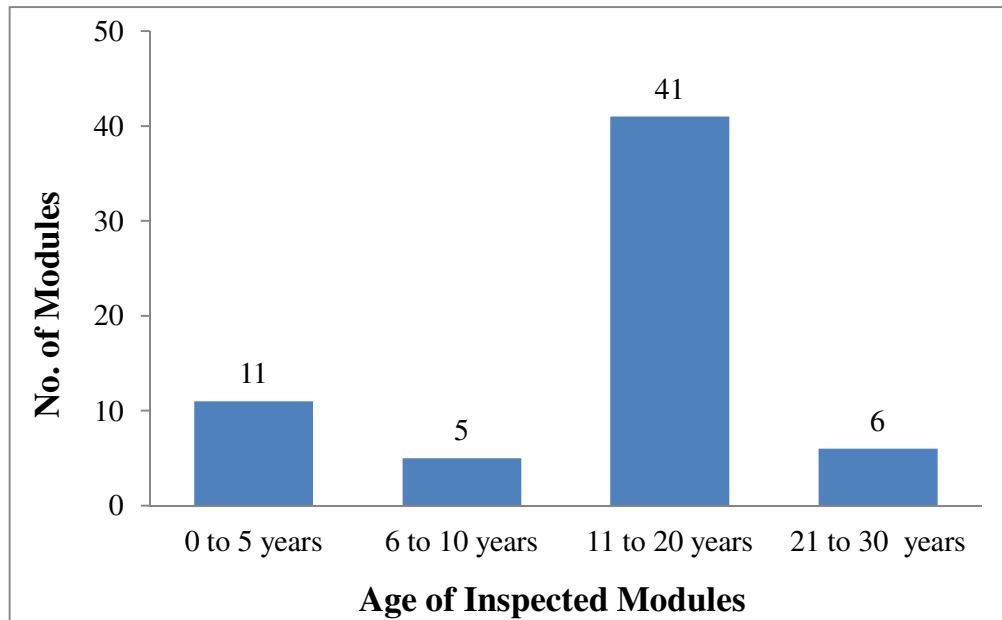

Fig. III: Age-wise distribution of the inspected modules

The electrical performance of the modules was recorded using a portable I-V curve tracer. A visual inspection checklist was also filled in on site, consisting of the physical characteristics of the module, information on balance of system components like inverter and battery, and some socio-economic information. At some of the sites, infrared thermography was also performed on the PV Modules. The electrical performance data has been extrapolated to Standard Test Conditions (STC) as per IEC standard 60891. Error analysis indicates that the uncertainty associated with the extrapolation is within 13.5% (for crystalline silicon modules) for data taken at irradiance level greater than 550 W/m<sup>2</sup>.

## 2. Degradation in Electrical Performance

The analysis of electrical degradation of the inspected modules has shown that the degradation rate of mono-crystalline Silicon is marginally better than that of multi-crystalline silicon (refer to Fig. IV). This (and following figures) shows the spread in the calculated values of average degradation per year of all of the modules measured in that category, based on the name-plate value and the currently measured value. The green horizontal line shows the median value. *It should be noted that since this survey focused mainly on visibly degraded modules, the average degradation rates should not be taken as representative for that class of technology. The degradation values reported for this survey are generally higher than the typical values reported in the literature, for this reason.* The degradation of the power output of mono-crystalline silicon modules has been found to be mainly

due to degradation in the short circuit current (Fig. V), which can be attributed to the physical degradation of the encapsulant, like discoloration and delamination of the EVA used. On the other hand, degradation in thin film modules (a-Si and CIGS) is mainly due to degradation in the fill factor (refer to Fig. VI).

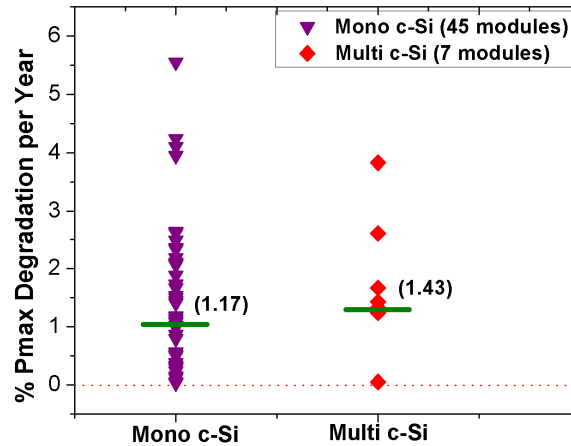

Fig. IV: Degradation rates of mono-crystalline silicon and multi-crystalline silicon modules

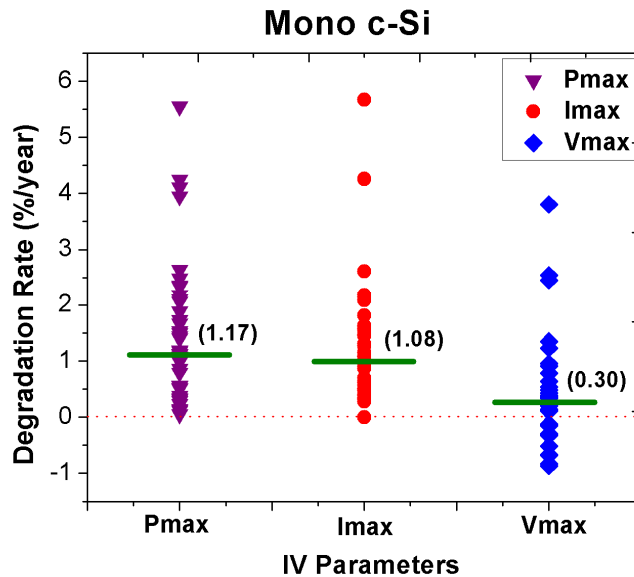

Fig. V: Degradation rates of various IV parameters for mono-crystalline silicon modules

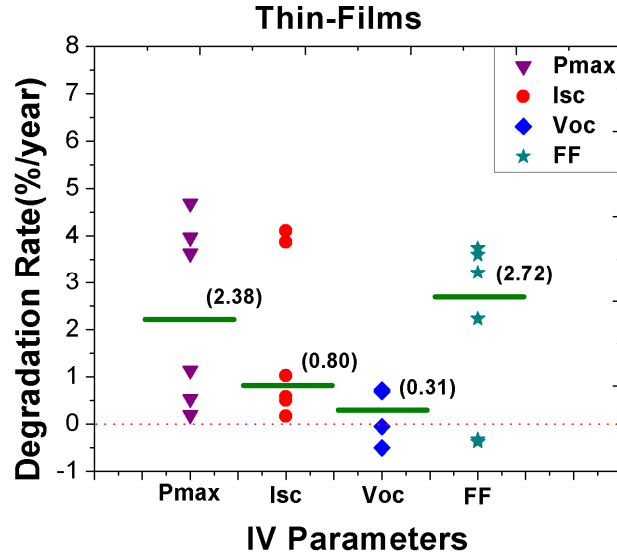

Fig.VI: Degradation rates of various IV parameters for thin film modules

The highest levels of module degradation have been seen in the Hot climatic zones (Hot & Dry as well as Hot & Humid zones) as compared to other climatic zones (refer to Table I and Fig. VII). Particularly interesting is that the Hot & Dry climate has a more deleterious effect on the modules than the Hot & Humid climate. Modules placed in the Hot & Dry zone are most susceptible to encapsulant discoloration, with the Hot & Humid zone coming second in the list. Corrosion of metallization and output terminals is most prevalent in the Hot & Humid zone as compared to other zones. Modules in the cooler climates perform much better (although the row for temperate climate should be discounted because of the paucity of data for that zone).

**Table I: Degradation rates of various IV parameters by climatic zone**

Climatic Zone	$P_{max}$ (%/year)	$I_{sc}$ (%/year)	$V_{oc}$ (%/year)	$FF$ (%/year)
Hot and Humid	1.29	0.98	-0.34	0.89
Temperate	0.24	-0.34	0.04	0.46
Composite	0.56	0.45	-0.17	0.64
Hot and Dry	1.55	0.78	0.20	0.51
Cold and Dry	0.19	0.72	-0.11	0.21

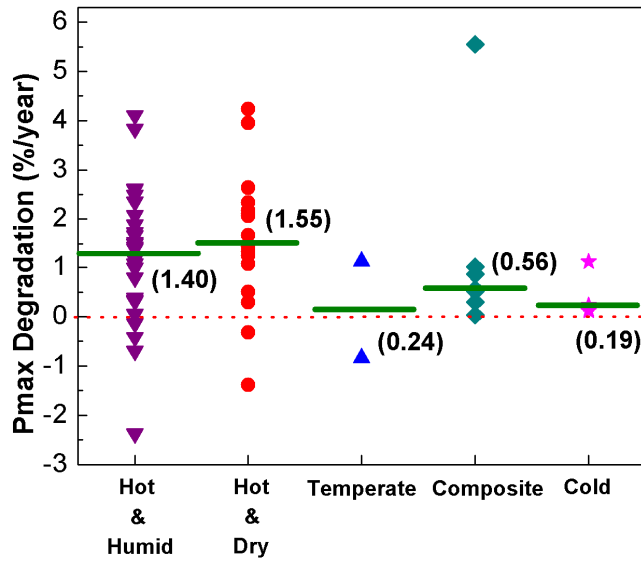

Fig. VII: Comparison of  $P_{max}$  degradation rates in different climatic zones.

### 3. Visual Degradation

The different types of degradation visibly seen on the modules have been shown in Fig. VIII. Discoloration of EVA, the most commonly used encapsulant now-a-days, results in a brownish colour on the modules, which lowers the amount of light transmitted to the solar cells. Corrosion leads to the reddish and greenish discolorations on the busbars and interconnects. The series resistance of the module increases due to corrosion of the metallization, leading to a reduction in fill factor and power output. Burn marks have been also seen in some of the PV modules. Delamination refers to the separation of the solar cell (or the top glass cover) from the encapsulant, which reduces the thermal conductivity at the site, and results in higher operating temperatures (as shown in the IR image alongside the delaminated module). In a few rare cases, we could find modules with shattered glass cover and these modules were actually performing quite well, but signs of corrosion due to moisture ingress could also be seen in such modules. The backsheets of the modules had bubbles in some cases, and sometimes we could also find chalking (generation of white powder) in the backsheets. Out of the various modes of module degradation, discoloration of the EVA has been found to be the most widespread (seen in 71% of the inspected modules), while the corrosion of metallization and interconnects comes a close second. The first mode reduces the short circuit current while corrosion decreases the fill factor, both ultimately reducing the power output of the module.

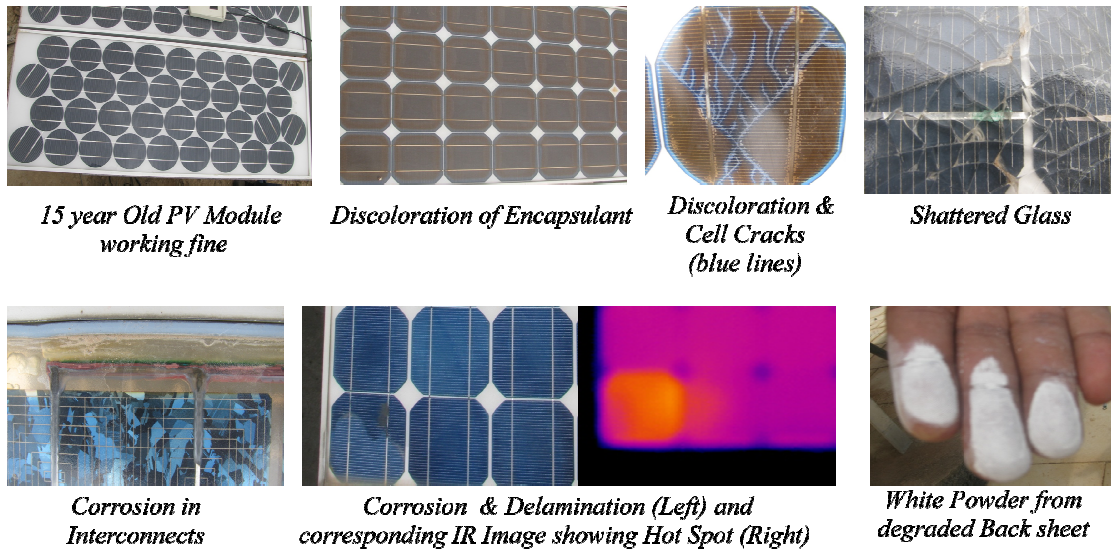

Fig. VIII: Different types of module condition/degradation seen during the survey.

The electrical degradation has been linked with the visual (physical) degradation of the PV modules. It is clear from these comparisons that degradation of EVA (discoloration and delamination) is the major cause behind the reduction in the short circuit current  $I_{sc}$ , as shown in Fig. IX. Also the direct relationship between series resistance and corrosion of metallization and terminals can be easily seen in the Fig. X.

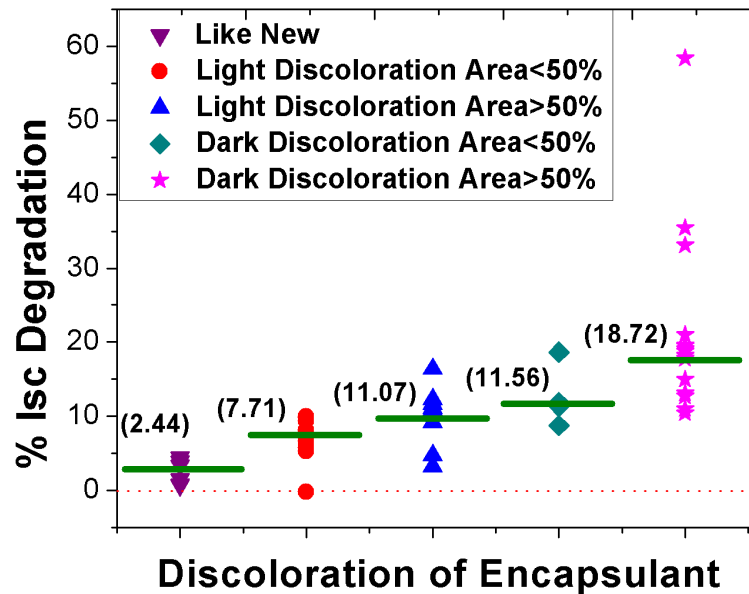

Fig. IX: Correlation between Short Circuit Current degradation and discoloration of EVA.

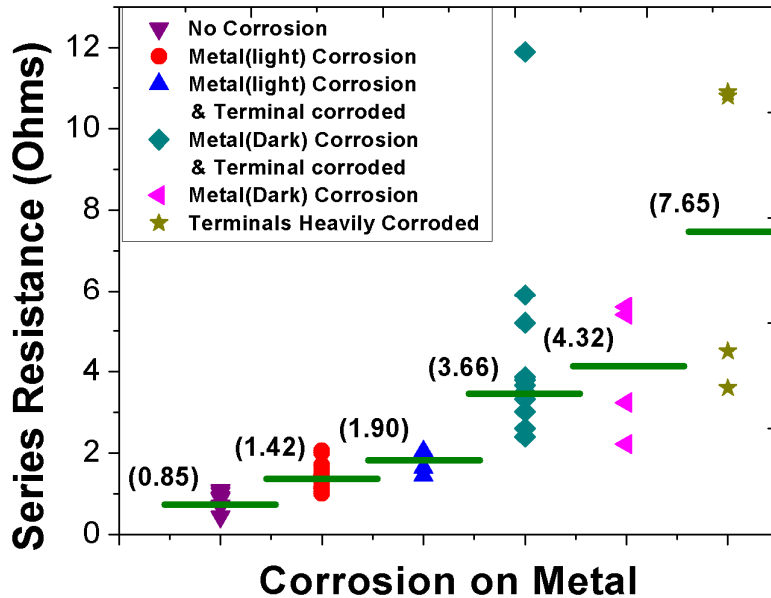

Fig. X: Correlation between Series Resistance of the Module and corrosion of metallization.

#### 4. Socio-Economic Analysis

We also did a “socio-economic” assessment of the installations, with respect to the ownership of the systems, financial models and the motivation for installation. This assessment was conducted to understand the degradation caused due to improper installation and negligence in maintenance.

Different types of ownerships identified in the survey were: (1) Private and individual owners (mainly households), (2) Private Institutions, (3) Public installations owned by user communities, and (4) Public installations owned by government institutions.

The different financial models associated with the installations were: (1) Systems with both capital investment and maintenance costs borne by private individuals or institutions (without any subsidies from government – mostly in installations where PV is a necessity), (2) Systems with the maintenance cost and part of the initial capital investment borne by private individuals/institutions (a certain percentage of initial investment being subsidised by government), (3) Systems where Government (or funds from non-governmental institutions) bore the complete initial cost, but the monthly operational and maintenance costs were borne by the end users, and (4) Systems where the government bore both the initial and running costs of the system (mainly the research institutes and government offices).

The issues with the private individual owners are improper installation, difficulty in accessing the rooftops for cleaning of modules, shading due to neighbouring trees and buildings, and irregular or no preventive maintenance. The additional cost requirement for proper support structures for the modules has often forced the individual users to lay the modules on their rooftops without adequate backside clearance for airflow. This also increases difficulty in accessing the modules for cleaning. In most of the cases periodic maintenance activities of the PV systems are not properly done.

Private institutions have installed PV systems mainly to save on their monthly electricity bills and in a few cases, to promote the use of green energy. The systems are usually properly installed and maintained.

Community-owned systems were found in places where PV is mostly a necessity or a better option than diesel-based power. These are usually located in remote areas. They are usually well installed and also well maintained.

PV systems in government institutions were mostly for demonstration or research purposes. Though usually well installed, they are not always well maintained.

An attempt was made to quantify the appropriateness in installation by allotting points for correct choice of location (shade-free and easily accessible), optimised tilt angle, orientation, and proper support structure. The maximum, minimum and the average points earned by different installations covered in the survey are categorised based on ownership and shown in Fig. XI.

**Score for overall appropriateness in installation**

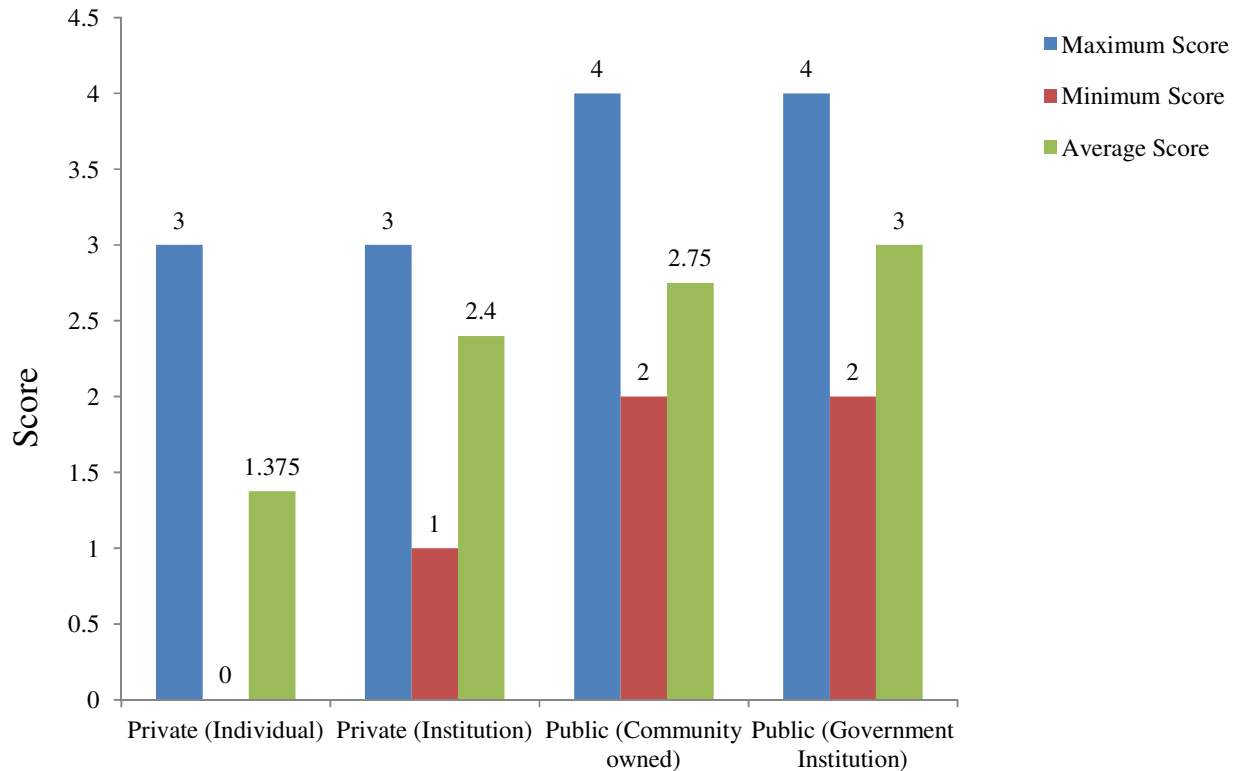

Fig. XI: Scores for overall appropriateness in installation

As seen, the average score is highest for government institutions, followed by for community-owned public installations. Next are installations owned by private institutions and, trailing far behind, are those by private individuals.

Shading was a common issue observed, irrespective of ownership and size of the system. This may be due to improper initial location, or subsequent growth of trees or nearby structures, since the installations are quite old. We found that partially-shaded modules were degrading almost three times faster than the un-shaded modules (as shown in Fig. XII), signalling what can be an important issue.

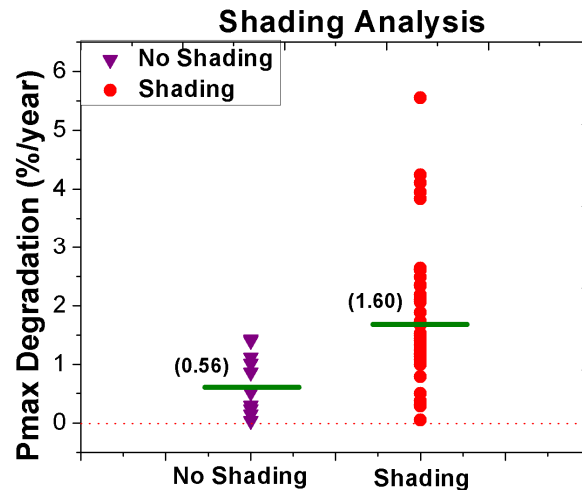

Fig. XII: Effect of Shading on module degradation rate

An analysis of the maintenance and cleaning cycles shows that maintenance activities are best taken care of in community-owned systems. Cleaning cycles are least regular in individual households. Both maintenance and cleaning cycles have important effects on the degradation rates.

The analysis shows that most of the installations in private individual households were self-financed without capital subsidy. This shows that people are willing to pay to meet their needs if PV is a good solution. But paradoxically, in most cases, the installation is quite poor. Private institutions with the driving force as savings/income generation have invested in PV even without capital subsidy from the government. They seem to be properly maintaining and operating the installations. The installations set up by the government to promote PV technology by demonstration, fully funded and maintained by the government, do not always serve the purpose, since our analysis shows that the two installations in this category are installed in a less than ideal manner, and are not maintained very well.

## 5. Conclusions

Based on the results of the survey, some of the major conclusions which emerge are:

- Mono-crystalline silicon performs slightly better than multi-crystalline silicon.
- Power degradation for c-Si in the hot zones (Hot & Dry as well as Hot & Humid) is significantly higher than in the other climatic zones (Temperate, Composite and Cold).
- Modules in Hot & Dry zones show more degradation in power than in Hot & Humid zones.

- Across climatic zones, the major causes for power degradation for c-Si are a reduction in short-circuit current, followed by a reduction in fill factor.
- In Hot & Dry zone, reduction in short-circuit current dominates, while in Hot & Humid zone, the reduction in fill factor also contributes significantly.
- Discoloration of encapsulant is the most widely observed visual degradation, followed by corrosion of metallization, interconnects and output terminals. It is most prevalent in the Hot & Dry climatic zone, since discoloration is accelerated by high temperatures. Amount of discoloration of encapsulant is directly co-related with reduction in short-circuit current (as expected), leading to loss of power.
- Corrosion of metallization, interconnects and output terminals is seen predominantly in Hot & Humid zone, and this is not unexpected. Corrosion is co-related with increase of series resistance, and thereby reduction of fill factor, leading to loss of power.
- Publicly owned (by communities or government) PV systems are better installed than privately owned ones.
- Private institutions and community owners have better cleaning cycles than either individual private owners or government.
- Publicly owned PV systems were generally better maintained, with preventive maintenance cycles, instead of just responsive repair.
- Co-relation of shadowing with performance shows that there is significant long-term degradation in partially shadowed modules, probably due to hot spots created by shadowing.
- Co-relation of cleaning cycle with performance shows that there is a long-term degradation of modules which are not frequently cleaned, probably because modules with accumulated dust run hotter.

## **6. Recommendations**

Based on the results and analysis, some general recommendations which can be made are:

- For modules to be deployed in the Hot & Dry climatic zone, encapsulant browning is the most serious long-term degradation mechanism, leading to a loss of power. The encapsulant characteristics of these modules should be critically analyzed, and appropriate accelerated tests on the encapsulant should be conducted before deployment in this climatic zone. In particular, if EVA is used as encapsulant, the formulation should include appropriate additives and UV stabilizers and cerium oxide containing glass should be used as top cover, which would reduce the rate of discoloration, and improve long term performance.

## ALL INDIA SURVEY OF PV MODULE DEGRADATION: 2013

- For modules to be deployed in the Hot & Humid climatic zone, corrosion is the main concern, followed by encapsulant browning. Due attention should be given to properly sealed junction boxes, and good electrical contacts (in addition to EVA as above) for modules to be deployed in this zone.
- Module degradation is minimal in the Cold & Dry climatic zone of Ladakh. This, coupled with the high radiation (can be in excess of  $1200 \text{ W/m}^2$  during summer), and generally cloudless skies, makes Ladakh an excellent place for solar energy generation.
- For stand-alone PV systems, performance can be significantly improved by proper installation, and regular cleaning and maintenance cycles. Technician training is a key to wider and better use of stand-alone and small grid-connected systems.
- The survey should be repeated in 2014 and 2015 to track the further degradation of the modules in the 2013 survey. The future surveys should also locate and assess more modules in the temperate and composite climatic zones, where the numbers in the 2013 survey were too small to draw statistically meaningful conclusions. Further, since most of the PV modules surveyed were quite old, they mainly belonged to the crystalline silicon category (mono- and multi-). Special efforts should be made in the 2014 and 2015 surveys to locate thin film modules.
- All the modules surveyed were off-grid (since the survey focussed on old installations). A separate survey should be taken up for the large grid-connected PV installations that have come up during the last 5 years, as this would give major leads into appropriate technologies and climatic zones for JNNSM.



# 1. Introduction

---

## 1.1 Introduction to Survey

India has taken up the challenge of generating 22 GW of solar energy by the year 2022. Accordingly, PV power plants are coming up at a fast pace all over India, both under central and state support policies. The current installed capacity stood at 1.4 GW as on March 2013 [2]. However, there is a dearth of information with regard to the durability and degradation of PV modules in Indian climatic conditions, which creates an uncertainty with regard to the long-term performance of the PV plants being installed currently. Hence the High Powered Task Force of MNRE had requested the National Centre for Photovoltaic Research & Education (NCPRE) at IIT Bombay with the task of surveying the condition of PV modules installed in earlier years in different parts of the country. Given the experience that Solar Energy Centre (SEC) – now National Institute of Solar Energy (NISE) – located in Gurgaon has in the area of module performance, NCPRE requested SEC that this survey be jointly undertaken. It was felt that the modules should have been in the field for 5 to 20 years, so as to get a reasonable idea of degradation. Accordingly, a survey team was formed, comprising of two research assistants from NCPRE and one researcher from SEC, working under the guidance of faculty members and senior researchers from NCPRE and SEC.

The survey visited 26 sites spread across 10 states of India in the months of May and June, 2013. Given that PV measurements are not feasible during monsoons, the team went first to Kerala and then moved to Chennai, Bangalore and Pune, before shifting the focus to the eastern states of India. Some of the oldest solar lighting systems were surveyed in the Sunderbans region in West Bengal, before visiting sites in Patna. Though the monsoons had not yet arrived, a low pressure depression had created overcast weather in Patna, and most sites in Patna had to be surveyed in rain. The sites in Gurgaon and Rajasthan were surveyed thereafter and the survey finally ended in Ladakh. It may be mentioned in passing that the Hanle observatory in Ladakh receives very little rainfall annually, but on the day of the survey, there were sporadic events of rain, and yet when the cloud cover dispersed, the irradiance meter showed radiation levels of  $1200 \text{ W/m}^2$ , seen nowhere else during the survey. As the analysis of the data presented in the following pages shall show, the cold climate of Ladakh coupled with the cloudless skies allows the PV modules to generate the maximum power while the degradation rates are the lowest seen anywhere in the country.

During the survey, a total of 63 modules were surveyed (excluding the 5 modules surveyed in Patna under rainy conditions, whose data has not been considered for further analysis since the data under

rainy conditions with very low irradiance cannot be extrapolated to standard reference conditions with reasonable accuracy). The assessment included measurement of the characteristics of the modules, measurement of the relevant weather and irradiance data, a visual checklist, and a survey of socio-economic factors associated with the installation. Since all of the installations were quite old, well before the current generation of power plants, most were at relatively small installations, including some academic and research institutions like IIT Madras & Solar Energy Centre, some government buildings like Kerala High Court and ICAR Patna, NGO offices like Auroville and Barefoot College Tilonia and the oldest solar mini-grids of the country in Sunderbans. *It should also be mentioned here that since a major aim of the survey was to understand the degradation seen in the modules, emphasis was given to modules which showed some visible signs of degradation. As a consequence, average degradation rates of the modules included in this survey are generally higher than the standard values for that technology in similar climatic conditions.*

## **1.2 Structure of the Report**

This report presents the analysis of the survey data in 3 parts – electrical degradation analysis, visual degradation analysis and analysis on socio-economic aspects. However, before entering into the analysis, the report provides a brief introduction to the present state of knowledge in PV module degradation in field (in Chapter 2), and also the methodology adopted for the survey (in Chapter 3). Degradation of PV modules is strongly related to the climate where they are installed. India is divided into 5 climatic zones and the details have been presented in Chapter 4. The actual analysis of the survey data starts from Chapter 5 onwards. The field data have been collected under various climatic conditions (different irradiance and module temperatures). For the sake of performance comparison and degradation analysis, it is necessary to convert all the data to some standard reference condition. This reference condition is prescribed in international standards as 1000 W/m<sup>2</sup>, 25 deg. C and AM1.5G solar spectrum, and this set of conditions is referred to as the standard test condition (STC). Chapter 5 mainly deals with this conversion and points out the errors associated with such conversions. A summary of the complete survey data can be found in Chapter 6. Chapters 7, 8 and 9 respectively deal with electrical analysis, visual analysis and socio-economic analysis of the survey data. We present our concluding remarks in Chapters 10 & 11 with recommendations for holding future surveys so as to build up a comprehensive database of PV module degradation in Indian climatic conditions. This would help in better decision making for research and economic investment in the Indian PV industry.

## 2. Literature Review

---

### 2.1 Introduction

Some background information is always required before a survey can be undertaken. Accordingly, before embarking on the survey, we performed a literature survey on PV module degradation issues. The PV module structure has undergone many modifications since the days of its inception, in order to improve its durability and performance. The first PV module developed by Bell Laboratories of USA in 1955 used 3 cm diameter solar cells, encapsulated in silicone oil within a plastic case and had efficiency of around 2% [3]. In later years, as the solar cell efficiency was progressively improved, the packaging material also underwent modifications so as to increase the durability of the module in the harsh outside environment. In 1976, Spectrolab Inc. of USA introduced the concept of laminating the solar cells to a glass coversheet using a polymer Polyvinyl butyral (PVB) with a backsheet of Mylar. PVB was a low cost alternative to the silicone encapsulant but it showed faster degradation when exposed to sunlight. Eventually PVB was replaced in the 1980s by Ethyl Vinyl Acetate (EVA) which was more stable than PVB while not costing so high as silicone. Also the Mylar backsheet was replaced by a combination of Tedlar/polyester/Tedlar with better resistance to UV rays and moisture permeation. A present-day PV module has a multi-layered structure – transparent cover at the top (usually glass) followed by the encapsulant that houses the solar cells along with the interconnect ribbons, and then the back-sheet polymer (please refer figure 8.1 in Chapter 8 of this report). An aluminum frame provides rigidity to the module by holding together all the components tightly from the four sides. Each of these components undergoes degradation by different means when exposed to the vagaries of the outside environment. Since the days of the first solar powered satellites, a lot of research has been done on the PV modules and their durability in both terrestrial and extra-terrestrial applications. In this section, we briefly review the literature on various aspects of PV module performance degradation in the following sections of this chapter.

### 2.2 Review of PV Survey Methodologies

There are numerous PV installations all over the world and the performance of many of the larger installations (mostly grid-connected MW scale power plants) are being continuously monitored at different levels of detail. On the other hand, the performance of smaller installations (as in residential areas) is often not monitored, though a few groups of researchers in different countries

have started surveys to gauge the performance of such small-scale installations also. There is often no consistency in the parameters that are reported in such surveys, as each group of researchers tend to give more stress on certain factors, while neglecting some others. In order to standardize the process of surveying the health and performance of the PV installations which would then help in the comparison of the data from different sources, C.E. Packard *et al.* from the National Renewable Energy Laboratory (NREL) have come up with a Visual Inspection Data Collection Tool in the form of a checklist [4]. This checklist focuses mainly on the “symptoms of degradation like discoloration and delamination” which can be documented in the field without needing any sophisticated equipment rather than the “diagnoses of degradation like electrochemical migration”, that would need specialized laboratory tests. In all, there are 14 sections in the checklist, each section concentrating on one component of the module (like front glass cover, or junction box etc.). A detailed description of the checklist is provided in Chapter 3, based on which we have developed a modified checklist for inspection of the modules during our All-India Survey 2013.

The measuring instruments play a significant role in determining the quality of the results of a survey on field performance. Kazuhiko Kato of AIST Japan has teamed up with some local PV installers in Japan to survey the residential PV systems’ performance [5]. In addition to the regular characterization equipments like infrared camera, automatic I-V tracer, and insulation tester, they used some innovative equipment like the Cell Line Checker, which helps to detect faults in the circuit and bypass diode. In our survey, we have used an automatic I-V Tracer in the field, and also had access to an Infrared camera in some of the sites.

The current-voltage characteristics of PV modules measured in the field needs to be translated to the Standard Test Conditions ( $1000 \text{ W/m}^2$  irradiance and  $25 \text{ deg. C}$  module temperatures) in order to facilitate comparison of the measured data with the nameplate rating of the module. W. Herrmann of TÜV Rheinland has published a report on the current-voltage translation procedure adopted for the I-V data collected from PV arrays installed under the German 1000 Roofs programme [6]. He has identified the various factors contributing to the overall uncertainty of the final translated parameters, including the measurement uncertainties (like optical and spectral mismatch between reference cell and PV modules, angle of incidence, non-uniformity of array temperature etc.) and the translation uncertainties. He has shown that different research laboratories in the European Union use different translation methods (algebraic method or numerical method) and the corresponding deviation between the translation results for power output can be as high as 4%. Finally he has recommended the use of the algebraic translation procedure developed by the Joint Research Centre of the European Commission. The associated translation accuracy even when only one array measurement

is taken and no module specific parameters are known, has been found to be within 4% (using the default values of the module parameters given in the document). D. Dernberger *et al.* have indicated the major sources of error in the measurement and translation of I-V data collected from PV arrays [7]. The uncertainty of measured power arises from uncertainties in calibration of the I-V curve tracer and irradiance and temperature sensor, from temperature difference between the module backsheet and the actual solar cell inside the module, and also from deviation of the incident spectral irradiance from the standard AM1.5G spectrum. The measured power needs to be further corrected for deviation of the actual irradiance and temperature from the standard test conditions, and this translation procedure introduces even more errors (due to uncertainties in the model parameters). They have performed a sensitivity analysis of the uncertainty in output power, and found that out of the four model parameters (temperature coefficient of current, temperature coefficient of voltage, curve correction factor and series resistance), the uncertainty in temperature coefficient of voltage has the strongest effect on the overall uncertainty. Also, the more is the deviation in temperature from 25 °C, the higher is the influence from the temperature coefficients and curve correction factor (curve correction factor explained in Chapter 5 section 5.2), while the deviation in irradiance from the standard 1000 W/m<sup>2</sup> strengthens the influence of the uncertainty in series resistance on the overall uncertainty. They have further iterated that I-V measurements should not be taken under unstable weather conditions, without clear blue skies or at irradiances much lower than 800 W/m<sup>2</sup>. They have arrived at an overall uncertainty in power output of 6.4% if the module I-V is taken at 800 W/m<sup>2</sup> and 65 °C, using technology-averaged values of the temperature coefficients and other parameters.

## **2.3 Performance of Different PV Module Technologies**

### **2.3.1 Electrical performance**

One of the most significant reports in the literature for the present survey is the paper by Jordan *et al.* on “Technology and Climate Trends in PV Module Degradation” [8]. This paper presents the statistical analysis of the degradation rate data reported in prior literature, showing its dependence on technology and climatic zones. The authors have done an extensive literature search which resulted in more than 1100 data points on degradation of the short circuit current, open circuit voltage and the maximum power output of modules in the field. They have systematically analyzed the degradation rate data to arrive at clues about the degradation mechanisms and their dependence on technology and climate. They have mentioned that discoloration and delamination are common signs of

degradation in modules, but failure of interconnect will cause greater decrease in maximum power output. It was found that the largest contributor to the output power decline in the case of crystalline silicon technology is short circuit current reduction, to a lesser degree the loss in fill factor and only to a very small extent the open circuit voltage. However in the case of thin film technology, the degradation in the power output is mainly due to the high degradation in fill factor. The reason for the high value of degradation in fill factor (FF) is light-induced degradation in case of amorphous silicon, and increase in series resistance for CIGS. The distribution of I-V parameter degradation rate by climatic zones also confirms that the main contributor to the degradation in maximum power output is the short circuit current. For desert type of climate, the degradation rate of short circuit current exceeds that of output power, while there is an improvement in the module open circuit voltage. The possible reason for reduction in short circuit current is the discoloration of the encapsulant due to the high ambient temperatures. In cold climate, a higher degradation in FF is noticed due to the snow load (resulting in cracking in front glass and cells) or due to the low temperatures (leading to interconnect breakage because of the brittleness of encapsulant at low temperatures). It was also observed that crystalline silicon technologies in hot and humid type of climate show significant degradation in almost all electrical parameters (not just short circuit current), as compared to other climates. These observations can help us to understand better which degradation mechanisms may be dominating for each climatic zone and for each technology. As pointed out by the authors, these findings can provide a basis for prioritizing the design of accelerated tests. This important paper provided the framework for the analysis of our survey data.

Wohlgemuth *et al.* [9] have discussed the performance of the test arrays of thin film modules that have been deployed at the Solar Energy Centre in India since 2002. The modules that were characterized include Cadmium Telluride (CdTe), Copper Indium Selenide (CIS) and three different types of amorphous silicon (a-Si). The modules were characterized using visual inspection, infrared thermography, electroluminescence (EL), wet Hi-pot tests and I-V measurements. The detailed analysis of the characterization shows that the triple junction a-Si module (without the double glass) had the best performance with less than 5% power loss from specification. For a-Si on glass (double junction a-Si), if the module suffered bar graph corrosion (where the TCO peels off the glass), major power loss was reported. However, the modules with no bar graph corrosion still met their original power specification. The CdTe and CIS modules had major power loss due to fill factor deterioration. EL pictures of the CIS modules show loss of photovoltaic activity around the edges where moisture would be expected to penetrate. Moreover, at high irradiances the I-V curve of the CIGS module shows significant series resistance. According to the authors, the reason may be that

the back contact is no longer fully ohmic, but rather has a reverse junction that impedes or offers a high resistance to the current flow.

O.S. Sastry *et al.* have monitored the performance of single crystalline silicon PV modules over a period of ten years under Indian field conditions [10]. The collected data indicates that the degradation in the performance of PV modules is more than the expected level. They have also made an interesting observation that PV modules of some IEC 61215 qualified module designs have degraded more than the guaranteed level in actual field conditions. They have concluded that the present qualification standards need to be revised in order to ensure reliable field performance of the modules deployed in harsh Indian conditions so as to survive for more than 20 years.

The study on the performance ratio (PR) being undertaken by O.S. Sastry *et al.* will help in identifying site-specific PV technology that offer maximum energy yield [11]. The yield in energy depends on the irradiance and temperature while the PR values mainly depend on the ambient temperature and the spectral response of the solar cells. Therefore we can conclude that PR values are site specific and depend on technology. This forms the foundation for identifying site-specific technology which can result in high energy yield. They have collected the data of the monthly and yearly energy yield for the three different technologies (HIT, amorphous silicon and multi crystalline silicon) installed at the Solar Energy Centre in Gurgaon. They have concluded that HIT and amorphous silicon single junction modules have performed better as compared to the multi crystalline silicon under similar conditions (in the composite climate of Gurgaon).

One of the common applications of solar photovoltaics is its use in street lighting systems. A. Sinha *et al.* have presented the performance analysis of some PV modules used with street lighting systems installed at Solar Energy Centre in 1990 [12]. Some of these modules have showed minimal degradation in power output (even less than that specified in IEC 61215 standard) even though they were installed in field for more than 21 years, and hence have been termed as “champion modules”.

Various degradation rates have been reported in the literature for PV modules installed in different climatic zones. Since the module performance is manufacturer and technology specific, often these degradation rates are found to vary significantly. It is imperative to take a look at some of the reported degradation rates, so that we know what we can expect from our survey results. We have compiled such data from several sources [13-16], which are shown in Table 2.1.

**Table 2.1: Degradation rates of maximum power output at different climatic regions for mono-crystalline and multi-crystalline silicon PV modules [11-14]**

Climatic region of test site	Location	Test Duration (Years)	Degradation Rate of Maximum Power (%/year)		Reference
			Mono c-Si	Multi c-Si	
<b>Temperate (Moderate)</b>	Perth (Australia)	1.5	2.7	2.9	[13]
	Hamamatsu (Japan)	10	0.62	NA	[13]
	Ispra (Italy)	22	0.67	0.3	[14]
	Lugano (Switzerland)	20	0.53	NA	[13]
	Cologne (Germany)	3	0.5	NA	[15]
<b>Hot and Dry</b>	Mesa, Arizona (USA)	4	0.4	0.53	[13]
	Negev desert (Israel)	3.4	NA	1.3	[13]
	Tucson (Arizona, USA)	1	1	1.65	[16]
	Sede Boqer (Israel)	3	0.5	NA	[15]
<b>Cold and Dry</b>	Berlin	1	1.25	1.05	[16]
	Golden, Colorado (USA)	8	0.75	NA	[13]
	Zugspitze (Germany)	3	2	NA	[15]
	INES, Chambéry (France)	2	NA	4	[16]
<b>Hot and Humid</b>	La Réunion Island (French island in Indian Ocean)	2	NA	5	[16]
	Serpong (Indonesia)	3	1	NA	[15]

### 2.3.2 Module component degradation

Often the degradation in the electrical performance of PV modules is due to physical and/or chemical changes in various module components which hinder the optimum performance of the PV modules. A survey of some existing PV systems established between 1980 to 2006 in South Korea had been undertaken by Gi-Hwan *et al.* from the Korean Institute of Energy Research (KIER) and Konkuk University [17]. They have reported that the major degradation modes are corrosion in interconnect ribbon, insulation failure, delamination and discoloration in EVA sheet. They have noticed that in a particular case, the power output of an 18-month old module reduced by as much as 3.5% without any visual degradation. At one of the sites having the oldest PV modules (installed in 1988), the degradation in output power was found to be 20-29%. Major problems reported for this site are EVA discoloration, delamination, cell breakage, and bypass diode corrosion. At another site, having multi-silicon modules in glass-glass packaging (glass as top cover and also as backsheet), corrosion in solar cells and humidity intrusion were found to be predominant. At other sites, the authors have observed delamination (whitening of EVA), backsheet swelling and corrosion of solar cell metallization. Quintana *et al.* [18] have grouped degradation observed in field systems into five categories, namely, “degradation of packaging material, loss of adhesion, degradation of cell/module interconnects, degradation caused by moisture ingress, and degradation of the semiconductor device”. While the semiconductor device (solar cell) actually does the work of converting sunlight into electricity, the interconnects conduct this electrical current into and out of the modules and the packaging materials (glass cover, encapsulant, back sheet and frame) provide the sensitive and fragile solar cells with structural support and insulate them from the outside environment. Given the stability of the semiconductor device, it is often the durability limitations of the packaging materials and interconnects, that determine the overall performance of the module [18].

#### 2.3.2.1 Degradation of packaging material

Glass breakage, dielectric breakdown, bypass diode failure, encapsulant discoloration, and backsheet cracking, delamination and chalking fall in the category of packaging material degradation. Packaging material degradation can lead to safety issues like ground faults and shock hazards. The intrusion of moisture into the module through broken glass or punctured backsheet can accelerate corrosion of the metallization. The module leakage current can also increase due to reduction in insulating property of the encapsulant.

#### 2.3.2.1.1 Glass breakage

Low-iron tempered glass is preferred for PV modules since the low iron content will allow higher transmission, while tempering the glass increases the tensile strength of normal annealed glass by a factor of 4. Tempered glass breaks up into small pieces rather than large glass chunks upon impact, which reduces the chances of people getting hurt due to glass breakage. In his presentation on “Why Glass Sometimes Breaks” [19], Chris Barry has indicated that PV glass can break due to tensile stress (bending/thermal), impact (hail stones/snow), crushing etc. He has also highlighted that certain glass compositions can show slight haziness upon long-term UV exposure. Also, water (dew) can dissolve some of the sodium from the top surface of soda-lime glass, which will produce an alkali that can then corrode the glass silicate structure. John Wohlgemuth *et al.* [20] have highlighted that stress build-up in the module glass, either during manufacturing or due to improper frame/mounting structures, can aid the process of glass breakage. High temperatures due to hot spots can also be the cause. The absence of the frame in most thin film modules makes them more susceptible to glass breakage since a small chipping at the glass edge during transportation or installation, can lead to a large crack in the long run, as the glass goes through the daily temperature cycling. Inappropriate mounting structure or poor clamping can often be the culprit behind damaged thin film modules [21].

#### 2.3.2.1.2 Bypass diode failure

Bypass diodes are placed in a PV module for bypassing the current flow when a series string of solar cells, owing to shading, is unable to support the current generated by the un-shaded series connected PV modules. If the bypass diode is not present, the shaded solar cells would go into reverse bias and start dissipating heat which in turn may lead to hot spots in the long run and damage the solar cells. K. Kato has mentioned that 593 out of 1272 modules in AIST Mega-Solar town in Japan have malfunctioning bypass diodes [5]. One of the major reasons for bypass diode failure is overheating, often due to under sizing [22]. Bypass diode failure can occur due to forward-voltage operation overheating (as the bypass diode is often placed in a sealed junction box with no air flow to cool it down), reverse-bias thermal run-away, transition from shaded to un-shaded condition, and even from overheating due to high intensity transients owing to nearby lightning strikes [23].

#### 2.3.2.1.3 Discoloration of encapsulant

The encapsulant in a PV module performs the task of protecting the solar cells from environmental stress and provides electrical isolation, while also coupling the front glass cover to the cells beneath

so as to allow maximum light to pass on to the solar cells [24]. Kempe *et al.* [24] have listed 5 different classes of encapsulants – Ionomer, Thermoplastic Polyurethane (TPU), Polyvinyl Butyral (PVB), Ethylene Vinyl Acetate (EVA) and Polydimethyl Silicone (PDMS). The earliest of PV Modules used PDMS but it was replaced by PVB in the mid 1970s so as to lower the costs. However, since PVB suffered degradation in the field, it was soon replaced by EVA (in 1980s) [25] [26]. Kempe *et al.* have indicated that the EVA film actually consists of multiple components, out of which 96 – 98% is EVA base resin, while the rest is Peroxide (for cross-linking), Hinder Amine Light Stabilizer (which decomposes any left-over peroxide radicals), Benzotriazole (acts as UV absorber), trialkoxy silane (adhesion promoter) and Phenolic Phosphonite (radical scavenger). They have reported that EVA's transmission reduces significantly upon exposure to UV accelerated aging tests (42 Suns at 80 – 95 deg.C), while that of silicone is not affected much.

Ethyl-vinyl acetate (EVA) is the most commonly used encapsulant in today's PV industry. Czanderna and Pern [27] have reviewed available literature in 1995 on the application of EVA encapsulant in PV modules, and indicated that EVA degrades under exposure to UV rays present in sunlight and also high temperatures. The degradation mechanism involves deacetylation of vinyl acetate pendant group (upon exposure to elevated temperature and/or UV radiation) resulting in the formation of acetic acid and polyenes,  $[-C=C-]_n$  (which impart the yellow colour to the encapsulant). Acetic acid acts as a catalyst and further accelerates the photo-thermal degradation of the EVA. Exposure of the polyenes to oxygen in the presence of UV reverses the discoloration, by photo-oxidation of the long-chain polyenes into shorter chain molecules. Cyasorb is often added to the EVA formulation as a UV absorber so as to prevent EVA discoloration, but cyasorb itself photo-decomposes in the long run. The authors have found that the commercially available EVA formulations often do not use the optimum ratios of the UV absorber (Cyasorb UV531) and UV stabilizer (Tinuvin 770). The discoloration of EVA directly affects the PV module output by cutting down the light reaching the solar cells underneath. Also the acetic acid produced due to EVA degradation may corrode the metallization and busbars. Thus, the factors that affect the discoloration rate of the EVA can be summarized as follows:

- (i) EVA formulation (ratio of UV absorber to UV stabilizer)
- (ii) Curing agent and curing conditions (which dictates the concentration of curing generated UV-excitable chromophores)
- (iii) Loss rate of the UV absorber
- (iv) Photo-bleaching rate due to diffusion of oxygen into the module
- (v) UV light intensity and UV filtering effects of glass superstrate

Holley and Argo [28] carried out detailed studies on the discoloration of the encapsulant and came to the conclusion that the main culprit behind the yellowing of EVA is the excessive use of the peroxide (Lupersol 101) which reduces the concentrations of the stabilizing additives (particularly the UV absorber) and hence the UV rays can attack the base EVA resin. They replaced the peroxide with Lupersol TBEC and found that the resultant EVA formulation had significantly lower discoloration (reduction by a factor of 2.5) in accelerated UV aging tests. Further they investigated the role of cerium oxide-containing glass in reducing the rate of discoloration and found it to be useful. *Based on these experiments, they have developed formulations of EVA which, when coupled with cerium oxide containing glass, can guarantee negligible discoloration during the lifetime of the PV Module.*

In 2010, McIntosh *et al.* [29] reported the effects of damp heat and UV aging tests on the light transmission properties of two common encapsulants – Silicone (polydimethylsiloxane, PDMS) and EVA. They have found that UV exposure for 1931 hours at controlled temperature of in the range of 55-65 deg. C, using a UVA-340 fluorescent lamp, resulted in no noticeable change in the absorption coefficient of both the silicone sample and the EVA sample. However, they have informed that similar experiments done by Kempe *et al.* [30] actually showed discoloration of the EVA samples, but the experiments were done at a higher dose of UV (42 Suns as compared to 1.2 Suns in [29]) and at higher sample temperature (78-95 deg. C) since Kempe *et al.* were considering modules for medium concentration (CPV) applications. In the Damp Heat tests conducted by McIntosh *et al.* [29], the EVA samples absorbed much more moisture than the silicone samples and consequently suffered greater loss in light transmission as compared to silicone. Based on these results, the authors have predicted that the silicone encapsulant will provide superior performance in long term field exposures than the standard EVA formulations.

Schmid *et al.* [31] have compared the performance and aging behaviour of PV modules with High Light Transmission EVA developed by Specialized Technology Resources (STR) Inc. of USA. They have found that it actually enhances the power output from the solar cells by about 1% by allowing more UV light to pass through (UV cut-off at 305 nm while conventional EVA has UV cut-off around 360 nm). Further, the authors subjected the High Light Transmission EVA to UV aging tests at relative humidity of 50% and 70 deg. C temperature, and found that while transmission of first generation EVA (A9918P from STR Inc.) reduced from 89% to 83.5% in 24 weeks under continuous UV exposure (ca. 61 W/sq.m. for 280-400 nm range), the transmission of presently available standard EVA formulation (15420P from STR Inc.) reduced very little (ca. 89% to 87.5% in 24 weeks exposure) while it stayed almost constant at 90.5% for the High Light Transmission EVA

formulation (Photocap 15505P HLT from STR Inc.) in the same time period. This hints that the advanced EVA formulations with High Light Transmission capability will not only enhance the PV module performance but can also maintain the performance in the field for long duration, without major discoloration.

Shuying Yang *et al.* [32] have tested EVA and backsheet samples for their low concentration PV modules (the encapsulant formulation being similar to what is currently used for standard flat plate photovoltaic modules). The authors exposed separate EVA samples to high temperatures for different lengths of time (96 hrs at 160 °C, 178hrs at 200 °C, 24 hrs at 200 °C and 48 hrs at 210 °C) and observed that these samples had discolored by different extents. The transmission spectra and Yellowness Index of these samples were determined using a Perkin-Elmer Spectrophotometer. The authors also calculated the short-circuit currents that can be expected from crystalline silicon modules having this discolored EVA, based on the transmission spectra of the discolored EVA and the quantum efficiency plot for crystalline silicon cells. They found that the percentage loss in short-circuit current would follow a linear relationship to the yellowness index of the EVA.

#### 2.3.2.1.3 Degradation of back-sheet

Different PV manufacturers have been using different materials as back-sheet, with the most common ones being a Tedlar-PET-Tedlar (TPT) composite and a Tedlar-PET-EVA (TPE) composite. Tedlar refers to a specific Poly-vinyl Fluoride (PVF) film developed by Dupont. Poly-Ethylene Terephthalate (PET) is an electrical insulator, with high mechanical strength and low moisture penetration, but hydrolyses (breaks down in the presence of water) easily, and degrades rapidly on UV exposure [33]. The PVF film has high UV resistance and also serves to protect the PET layer behind it from the ambient moisture. In order to optimise the cost of the module versus the durability and performance, many manufacturers opt for a single layer of Tedlar as the backsheet. Fluoropolymers like Kynar (brand name for PVDF, Poly-vinylidene Fluoride) have been introduced in the market, which the manufacturers claim provide the same level of performance as Tedlar [34]. However, G. Oreski *et al.* have found significant degradation of PVDF and PET films in Damp Heat Test (conducted inside a chamber with temperature and humidity maintained at 85 °C and 85% respectively) whereas PVF film showed “excellent” stability [35]. Some of the module manufacturers use only a single layer of standard grade PET in their back-sheet, which tends to degrade (cracking & yellowing) within a few years of outdoor exposure [36]. However, a hydrolysis-resistant grade of PET is also available in the market, and experiments conducted by

Namsu Kim *et al.* have shown that the degradation rate of PVDF-PET back-sheet is much faster than the hydrolysis-resistant backsheets in Damp Heat Tests [37].

### 2.3.2.2 Loss of adhesion

Loss of adhesion leads to delamination (separation of the various layers in the module laminate). Front-side delamination (at glass/encapsulant and encapsulant/cell interfaces) has been found to be more common than backside delamination. Front side delamination will affect the optical coupling of the various layers, leading to increased reflection from the module surfaces and hence lower the short circuit current of the module. Tsuyoshi Shoida [38] has shown that delamination over a solar cell can reduce the short circuit current by almost 43%. He has reported that most of the field-aged PV modules show delamination along the edge of the busbars and SEM images reveal that delamination is occurring between the TiO<sub>x</sub> anti-reflective coating and the EVA, owing to the differences in the coefficient of thermal expansion. Further, delamination will affect the thermal coupling of the various layers and reduce the heat transfer rate, owing to which the cells will operate at higher local temperatures as compared to the rest of the module, thus forming hot spots. This also increases chances of reverse-bias cell heating [18]. Also there is a possibility of accumulation of moisture in the delaminated void which can lead to corrosion of the metallic contacts. According to N. G. Dhere *et al.* [39], delamination has been observed to varying extents in a small percentage of modules from all manufacturers. Also delamination is “more frequent and severe in hot and humid climate.” Dhere *et al.* have indicated that high concentration of impurities have been observed at the delamination sites. Migration of sodium from soda-lime glass to the glass-EVA interface tends to cause delamination at that interface, and hence it is recommended to use low sodium content glass for PV modules. Also, migration of phosphorus from the solar cell to the EVA-solar cell interface can cause delamination [39].

### 2.3.2.3 Degradation of cell/module interconnects

Interconnect degradation refers to the change in the structure or geometry of the cell-to-ribbon or ribbon-to-ribbon contact areas [18]. In some cases, the tin (Sn) and lead (Pb) separate out from the solder alloy, leading to formation of larger metal grains. Thermo-mechanical stress can create cracks in these grain boundaries, which may lead to joint failure. Reduction in the number of redundant solder joints and creation of voids in the joints reduces the effective contact area and increases the series resistance. This can also lead to higher cell temperatures and localized hot spots causing burns to the solder joints and adjoining components. In thin film modules, the junction box interconnect

strap has been found to detach from the cell frit, owing to thermo-mechanical fatigue caused by daily thermal cycling. K. Kato [5] has mentioned that among 32 nos. 10-year old residential PV systems in Japan that his team has surveyed upon receiving complaints of bad performance, more than 80% of the systems had solder bond failures of cell interconnect ribbons apart from other degradation issues.

#### 2.3.2.4 Degradation caused by moisture ingress

Moisture can enter inside the PV module through the back-sheet or the edges of the module laminate. It will cause corrosion in the cell metallization of crystalline silicon modules and in semiconductor layers of thin film modules. The sodium present in the glass can react with the moisture leading to formation of weak alkalis that in the long run can corrode the metallization [18]. Moisture also tends to increase the electrical conductivity of the encapsulant and hence increases the leakage current and results in performance degradation. Moisture intrusion can be the root cause behind delamination in the module and delamination in turn would increase the temperature of the affected sites and accelerate the degradation process.

Hulsmann *et al.* from Fraunhofer Institute have conducted a simulation study of water vapour ingress into wafer-based PV modules [40]. They have compared the variation of ingress rates across four climatic zones (tropic, moderate, alpine, and arid). In addition to the weather parameters, the equilibrium concentration of water was also determined by the encapsulant and back-sheet combination. The equilibrium concentration is lower in Poly-amide (PA) based back-sheet when compared to Poly-ethylene-terephthalate (PET) based back-sheet at lower temperatures. Both of them have comparable permeability at 30°C but the permeability of PA is more temperature-dependent and provides more breathable back-sheets in dry conditions (day time) and acts as a better barrier at lower temperatures (night). It was observed that faster water ingress rates during initial stages of module exposure occurred in warmer regions. But the highest equilibrium value of water concentration in the encapsulant was found in places with moderate temperature. Modules incorporating silicone encapsulation generally exhibited lower degradation when compared to EVA encapsulant. Glass-glass modules generally exhibited a greater degradation than glass-polymer construction.

#### 2.3.2.5 Degradation of the semiconductor device

Degradation of the solar cell device itself can be due to various causes. Light Induced Degradation (LID) occurs in crystalline silicon cells within the first few hours of outdoor exposure and reduces

the short-circuit current by 1-5% [18], whereas LID in amorphous silicon modules continues for a few months, which can lead to a reduction in efficiency of about 10% to 30% [41]. The LID effect in crystalline silicon solar cells has been generally attributed to boron-oxygen defects in the boron doped P-type wafer manufactured by the Czochralski (CZ) process. Bhushan *et al.* [42] have investigated the contribution of the surface effect (interface deterioration between the silicon nitride anti-reflection coating and the solar cell due to light) and the bulk effect (recombination induced by the boron-oxygen complexes) to the overall LID in crystalline silicon solar cells. They have found that while the bulk effect can be eliminated by annealing the wafer at 200 °C (which drives out oxygen from the wafer), the surface effect cannot be eliminated by such an annealing process. Further, the surface LID effect is also present in multi crystalline silicon solar cells, which do not show any bulk LID effect. Light induced degradation in hydrogenated amorphous silicon modules, referred to as the Staebler-Wronski effect, is a result of the formation of dangling bonds (due to breakage of weak silicon-silicon bonds) which act as recombination centres thereby lowering the lifetime of the charge carriers [43].

Another form of degradation in crystalline silicon modules is the migration of phosphorus ions from the doped silicon cell to the top surface where it assists in the delamination of the encapsulant by reducing the adhesion strength. Similar migration of sodium from the glass superstrate towards the encapsulant layer also enhances the delamination process [39].

Cracking of the fragile silicon cells has often been reported from the field. The area isolated from the rest of the cell due to cracking determines the extent of loss in power output of the cell. In amorphous silicon cells, electrochemical corrosion of the Transparent Conducting Oxide (TCO) has been a cause of concern. Referred to as “bar graph corrosion”, it is assisted by sodium migration from the glass, water vapour and internal electric fields [18].

### **2.3 Socio-Economic Aspects**

Degradation of PV systems due to improper installation and lack of maintenance are often reported in literature, especially in case studies of rural electrification projects using PV technology. The major reasons stated in the literature are the degradation in performance due to shading and poor maintenance by unskilled technicians, resulting in replacement of damaged parts with improper components [44]. The reasons for improper maintenance, when investigated were mainly found to be linked with the ownership type of the systems and the financial models for funding the initial investment. A case study on SELCO titled “A PV system and service providing company in rural

India” [45] has revealed that whenever there are regular income and cash flows associated with a PV product/system, the probability of maintaining that system well is high. One of the reasons for failure of early projects on dissemination of PV lanterns in India was the unavailability of spare parts and non-replacement of damaged parts, as reported in the study by Chaurey and Kandpal [46].

A study on PV dissemination trajectories in Ghana, Kenya and Zimbabwe [47] has helped in identifying ‘donor driven’ implementations as a major mode of PV dissemination. It also strengthens the importance of linking PV installation with income generation activities such as agriculture, especially in rural areas. This gives us an indication of the willingness of the people to pay for PV to meet their basic needs. This paper also refers to the analysis of institutional models based on ownership of systems. The paper by Jafar [48] states that the nature of maintenance support and the expenses on maintenance can be studied effectively by categorising the installations based on their ownership. The paper concludes that maintenance activities are more effective if they are done by a third party at a reasonable service charge. Another case study from China shows that promoting a local free market can be more effective than subsidy driven donor based programs [49].

The importance of installing the modules at an easily accessible place has been emphasised in a case study by El-Shobokshy *et al.* [50] in their paper dealing with the degradation of solar cells due to accumulation of dust. The importance of regular cleaning of modules is also highlighted in a study from Algeria [51]. Similarly, shading of single module based rooftop home lighting PV systems was found to be a serious issue and it resulted in disabling the entire system very often. The issue of shading was better addressed in larger installations where many modules are interconnected in the form of arrays [52].

Studies conducted as early as the 1980s have compared roof mounted decentralised systems with community based village centric systems and have concluded that village energy centres are technically and economically more viable than individual rooftop systems. Better maintenance, superior load management and better security are some of the advantages of centralised systems [53]. However, there are reports which contradict the above results and actually support the individual solar home systems (SHS) mode of dissemination. They find that the independence in operational aspects and increased responsibility of users due to individual ownership ensures better maintenance of PV systems [54]. A detailed study by Cust *et al.* [55] provides adequate inputs for designing a framework for analysing renewable energy based rural electrification projects based on the ownership of assets of generation, distribution and end use of the generated power. The study has identified mainly 4 types of PV systems, based on ownership, scale and application. The first

category is the government-owned generation as well as distribution systems which provide power to households. The second category is one in which the government owns / sponsors the generation infrastructure, whereas a local energy community takes care of the distribution and maintenance. The third category is one in which private and non-governmental organisations own / sponsor the generation assets which may be funded by external aid, and the distribution assets and the maintenance works are managed by a rural co-operative. The fourth and the final model include the small-scale household level SHS owners who are independent of any government or private schemes.

Based on the insights from the above literature as well as a few other case studies [56], [57], [58], [59], [60] and [60] we have developed a framework for analysing the socio-economic aspects based on ownership, financial model and the end purpose of the installation.

## **2.4 Conclusion**

We have presented an overview of the reported literature on PV module degradation. The NREL Visual Inspection Data Collection Tool [4] has provided us a basis for the systematic collection of data during our All India PV Survey. The paper by Jordan *et al.* on the “Technology and Climate Trends in PV Module Degradation” [8] has provided a framework and benchmark which helped us in analyzing our survey data. We have extensively compared and validated the results of our analysis with those of Jordan *et al.* Dirnberger’s paper on uncertainty of field I-V measurements [7] has provided us insight into the various factors responsible for the uncertainty in calculated degradation rates. Overall, the available literature has been an excellent source of reference for us and we have tried to follow the procedures and guidelines set out in the literature as far as practically possible. In the next chapter, we shall present a brief introduction to the various tools we have used in our survey, including the visual inspection checklist.

## 3. Survey Methodology

---

### 3.1 Introduction

The main objective of this survey was to understand the degradation mechanisms of PV modules deployed in different climatic zones in India. In order to achieve this objective, mainly three types of observations/measurements were carried out in the survey sites:

- **Measurement of electrical parameters of the PV modules** – Measurements were performed on site to understand the present performance status of the modules and quantify their degradation in terms of their basic electrical parameters ( $V_{oc}$ ,  $I_{sc}$ ,  $P_{max}$ , etc.)
- **Observation of the visual defects or degradation** – The visual defects and degradation of modules were observed and the nature of defects (such as delamination, corrosion of bus bars, yellowing of EVA, etc.) was documented.
- **Observations on the socio-economic factors** – Information on factors such as incorrect methods of installation, improper maintenance of modules due to ignorance of the user, etc., which may have a bearing on degradation, was noted. Details on the ownership of the PV system, its impact on the users, source of capital investment and other financial aspects were also noted.

For electrical performance evaluation, an automatic I-V tracer was used, along with module temperature detector (Resistance Temperature Detector) and solar irradiance detector (silicon reference cell). The temperature and irradiance data facilitated the conversion of the measured I-V curve to standard test conditions (STC), so that these can then be compared with the name plate data of the module and the average degradation rates (difference of name plate data and measured data divided by the number of years the module was installed in field) can be calculated. Also at some sites, an Infra-red camera was made available by Solar Energy Centre (SEC) Gurgaon, which enabled us to take thermal images of the modules to locate hot spots. The survey team was also equipped with tools like multi-meter, ambient temperature & humidity sensor, tilt angle meter (to measure the inclination angle of the module with respect to horizontal) and compass (to know the direction in which the modules are facing). The specifications of the major equipments are given in the next section.

## 3.2 Equipment Specifications

### 3.2.1 I-V tracer (See Fig. 3.1)

Make & Model : MECO Solar System Analyzer

Measurement Method : Four Probe Measurement

Parameter	Range	Resolution	Accuracy
Voltage	0 – 1000 V	0.001V (for 0V – 1V), 0.1V (for 1 V – 100V), 1V (for 100V – 1000V)	1% of range $\pm$ (1% of Voc $\pm$ 0.1V)
Current	0.1 – 12 A	1 mA (for 0.1A – 1A range), 10 mA (for 1 A – 12A range)	1% of range $\pm$ (1% of Isc $\pm$ 9 mA)
Irradiance	20 – 2000 W/sq.m.	1 W/sq.m.	3%
Temperature	-20 to 105 °C	0.1 °C	1%, 1 °C

### 3.2.2 Infrared camera (See Fig. 3.2)

Make & Model : Wuhan Guide Infrared Co. Ltd. - EasIR-4

Detector Type : Uncooled FPA microbolometer (160x120 pixels, 25  $\mu$ m)

Spectral Range: 8 – 14 micrometer

Thermal Sensitivity:  $\leq$  100 mK at 30 °C

Field of View / 20.6° x 15.5° / 11 mm

Focus

Focus adjustment Automatic & motorised

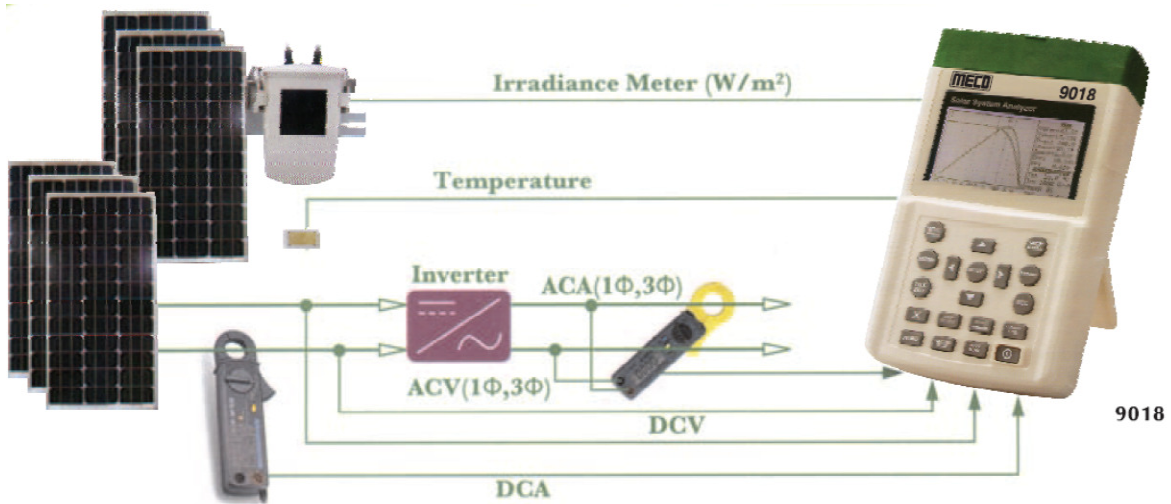

Fig. 3.1: Schematic of the I-V Tracer, showing the Temperature sensor and the Irradiance meter. Also shown are the DC and AC Clamp meters for determination of Inverter Efficiency. [Image from Manufacturer Datasheet]



Fig. 3.2: EasIR-4 Infrared Camera [Image from Product's User Manual]

### 3.3 Survey Checklist

For every module inspected, a survey sheet was filled up, comprising of the visual degradation checklist, which was modeled on the NREL checklist [4], but also included additional items like information about the inverter and battery system and also social survey information like the initial cost of the system and the subsidy amount. A fully filled sample sheet is given in Appendix I. The selected options are indicated by the red dot.

### 3.4 Precautions

The following precautions were taken for proper data collection during the survey:

- i) Modules have to be cleaned properly before taking their I-V data. If water is used for cleaning, it has to be made sure that there are no droplets of water left on the panel surface (by proper wiping) and also sufficient time has to be given for the module temperature to become uniform (at least 5 minutes) before starting the I-V measurement.
- ii) It is recommended that I-V data should be taken only when the irradiance is higher than  $600 \text{ W/m}^2$  and not varying rapidly and wind speed is as low as possible (the recommended time is a cloudless sunny day between 10 AM and 3 PM). Also module temperatures should be as close to  $25 \text{ }^\circ\text{C}$  as possible (by cleaning the module with cold water) in order to minimize the temperature correction error.
- iii) Insulating gloves and shoes should be worn while making the circuit connections.
- iv) Before taking the I-V measurement, an IR image of the complete module should be taken in order to locate the hot spots, to avoid placing the temperature sensor underneath those hot spots while taking the I-V.
- v) The I-V tracer's probes should be connected directly to the module terminals (and not through extra wires) since any extra connecting wire would induce voltage drop and cause error in the measurements.
- vi) The irradiance sensor has to be placed in the same plane as the module (at the same inclination and orientation).
- vii) When taking the I-V measurement, it has to be ensured that no object is shading the module and the irradiance sensor.
- viii) When I-V measurement is going on, one has to keep constant watch on the module temperature measurement probe, which can sometimes detach from the panel and fall to the ground.

### 3.5 Conclusion

The survey should be undertaken only under bright sunshine so that the electrical performance data can be interpreted accurately. The portable I-V tracer is the most important tool for the survey, without which it is not possible to undertake such a survey. Since the PV module degradation is dependent on the local climatic conditions, we shall discuss the various climatic conditions prevalent in India in the following chapter.

## 4. Climatic Zones of India

---

### 4.1 Introduction

The performance of a module and its degradation depend on the local climatic conditions. India is a vast country, with a land area exceeding 3 million sq.km., covered by water bodies on three sides and mountains on the fourth. Due to the vast geographical span, different parts of India experience different climatic conditions – places in north-western India have dry weather for most part of year whereas the coastal regions of the country experience high humidity and the places in the northern tip have cold dry climate.

### 4.2 Climatic Zones Classification Criteria

The climatic zone for a place is selected based on the climate prevalent at the site for more than 6 months. According to the study by Bansal *et al.* [61], India can be divided into six climatic zones, namely, Hot & Dry, Warm & Humid, Moderate, Cold & Cloudy, Cold & Sunny and Composite. The criteria of this classification are shown in Table 4.1. However, the latest Indian Standard on Building Design published by Bureau of Indian Standards considers 5 climatic zones, by combining the Cold & Cloudy and the Cold & Sunny zones into the Cold Zone, while keeping the other zones intact (Moderate zone is renamed as Temperate zone). We have followed the latest 5 climatic zone classification (namely Hot & Humid, Hot & Dry, Composite, Temperate and Cold) in our report. As shown in the Table 4.2, places having mean monthly maximum temperature higher than 30 °C and mean relative humidity less than 55% can be grouped under the Hot & Dry category. Similarly, the temperature and humidity criteria for the other climatic zones can be seen in this table. Places which experience both hot, cold & humid conditions for some part of the year and no single climatic pattern extends for even six (6) months, are clubbed in the “Composite” category, and experience very dry summers, wet rainy season, and also cold winters.

**Table 4.1: Climatic Zone Classification criteria as per Bansal *et al.* [61]**

Climate	Mean Monthly Temperature (deg. C)	Mean Relative Humidity (%)
Hot & Dry	>30	<55
Warm & Humid	>30	>55
Temperate	25 – 30	<75
Cold & Cloudy	<25	>55
Cold & Sunny	<25	<55
Composite	This applies when six months or more do not fall within any of above categories	

**Table 4.2: Latest Climatic Zone Classification criteria [1]**

Climate	Mean Monthly Maximum Temperature (deg. C)	Mean Relative Humidity (%)
Hot & Dry	>30	<55
Warm & Humid	>30	>55
	>25	>75
Temperate	25 – 30	<75
Cold	<25	All Values
Composite	This applies when six months or more do not fall within any of above categories	

### 4.3 Sites Surveyed in Different Climatic Zones

As per five-zone classification, the coastal area of India (like Mumbai, Chennai and Kolkata) will fall in the Warm & Humid zone, whereas the central parts of India (including the capital city of New Delhi) will fall in Composite zone. Places in the central western part of India like Jaipur and Jaishalmer lie in the Hot & Dry zone. Bangalore falls in the Temperate climatic zone whereas northern states like Jammu & Kashmir experience Cold climate. The various climatic zones in India

## ALL INDIA SURVEY OF PV MODULE DEGRADATION: 2013

have been shown in the Fig 4.1, along with the cities where the survey has been conducted (in red dots). As evident from the figure, all the zones have been covered in this survey. However, the number of sites (refer Table 4.3) is not evenly distributed, with most of the sites falling in the Hot & Humid zone.

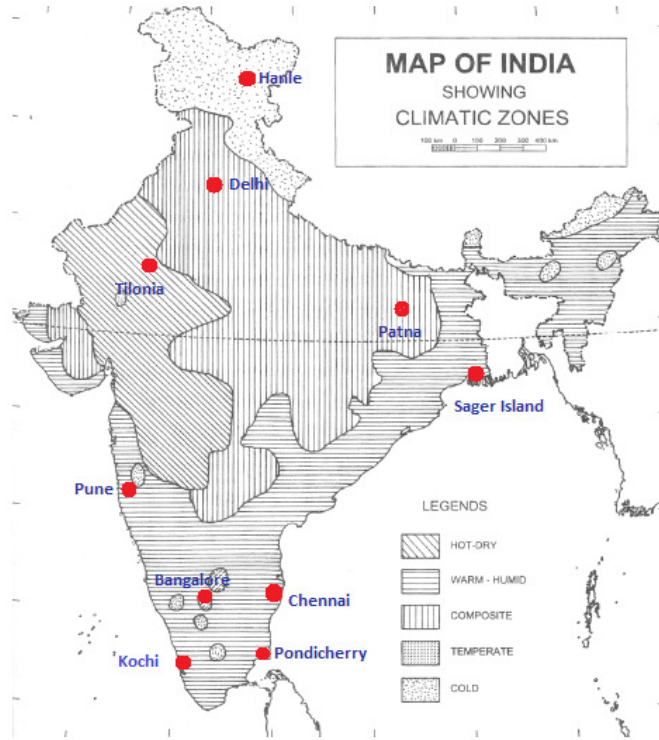

Fig. 4.1: Climatic Zones of India (Sites covered in the Survey have been marked in red) [1]

**Table 4.3: Survey site statistics**

Climatic Zone	No of Sites	No of Modules
Hot & Humid	16	31
Temperate	2	2
Composite	5	17
Hot & Dry	2	10
Cold	1	3

## **4.4 Conclusion**

There is a wide difference between the climatic conditions prevalent in different parts of the country. Hence the performance of the PV modules would vary significantly depending on the location and it is not possible to give a single figure of performance for the entire country. The field data have been collected under various climatic conditions (different irradiance and module temperatures). For the sake of performance comparison and degradation analysis, it is necessary to convert all the data to some standard reference condition. The following chapter mainly deals with this conversion and points out the errors associated with such conversions.

# 5. Analysis and Corrections applied to Survey Data

---

## 5.1 Introduction

During the survey, module I-V data were measured at different conditions of irradiance and temperature. In order to compare their performance it was required to translate the measured I-V data to some standard condition. International Electrotechnical Committee (IEC) has defined standard test condition (STC) for PV modules as  $1000 \text{ W/m}^2$  irradiance with AM 1.5G spectrum and  $25^\circ\text{C}$  module temperature. IEC has also published some standard correction procedures (contained in IEC 60891) for translating between different irradiance and temperature values. We have used a modified version of IEC 60891 correction procedure 1 for translating our survey data. In this chapter, we discuss the correction procedure and the error associated with such translations. Regarding the choice of mean and median to represent our data set, we have preferred median because they are less affected by the outliers, as described later. A software package which has been developed to perform such translations is also described in this chapter.

## 5.2 IEC 60891 Correction Procedure

The IEC 60891 standard defines a procedure that helps to translate the measured I-V characteristics of photovoltaic devices to standard test condition (STC) i.e.  $1000\text{W/m}^2$  irradiance and  $25^\circ\text{C}$  module temperature. Correcting I-V characteristics to STC helps in comparing the performance of different modules. IEC 60891 also defines the procedures used to determine factors relevant for these corrections. There are three procedures for correcting the measured I-V characteristics to other conditions of temperature and irradiance (such as STC). The first procedure consists of two equations, one for correcting current and other for voltage, thereby correcting each point of the entire I-V curve. The second method is an alternative algebraic method which yields better results for larger irradiance corrections ( $>20\%$ ). In both procedures, correction parameters must be known or determined prior to the correction. The third procedure is an interpolation method which does not require any correction parameters.

### 5.2.1 Correction procedure 1

The measured current-voltage characteristics shall be corrected to standard test conditions or other selected temperature and irradiance values by applying the following equations:

$$I_2 = I_1 + I_{sc} * \left( \frac{G_2}{G_1} - 1 \right) + \alpha * (T_2 - T_1) \quad \dots(5.1)$$

$$V_2 = V_1 - R_s * (I_2 - I_1) - k \cdot I_2 * (T_2 - T_1) + \beta(T_2 - T_1) \quad \dots (5.2)$$

where:

$I_1, V_1$ : Coordinates of points on the measured characteristics

$I_2, V_2$ : Coordinates of the corresponding points on the corrected characteristic

$G_1$ : Irradiance measured with the reference device

$G_2$ : Irradiance at the standard or other desired irradiance

$T_1$ : Temperature of the test specimen

$T_2$ : Standard or other desired temperature

$I_{sc}$ : Measured short-circuit current of the test specimen at  $G_1$  and  $T_1$

$\alpha, \beta$ : Current and voltage temperature coefficients of the test specimen

$R_s$ : Internal series resistance of the test specimen

$K$ : Curve correction factor

Note that Equation (5.1) is only applicable for I-V curves measured at irradiances which are constant during the acquisition of the entire I-V curve.

### 5.2.2 Correction procedure 2

This correcting procedure involves five I-V correcting parameters for its translation equations. These parameters can be obtained by measurement of I-V at different temperatures and irradiances. Apart from temperature coefficients for short-circuit current and open-circuit voltage, an additional

temperature coefficient ( $k'$ ) is used which accounts for changes of the internal series resistance (and fill factor) with temperature.

The correction procedure is defined by the following equations for current and voltage:

$$I_2 = I_1 * (1 + \alpha_{rel} * (T_2 - T_1)) * \frac{G_2}{G_1} \quad \dots(5.3)$$

$$V_2 = V_1 + V_{oc1} * \left( \beta_{rel}(T_2 - T_1) + a \ln\left(\frac{G_2}{G_1}\right) \right) - R'_s * (I_2 - I_1) - k' * I_2 * (T_2 - T_1) \quad \dots(5.4)$$

where:

$I_1, V_1$  : Coordinates of points on the measured characteristics

$I_2, V_2$  : Coordinates of the corresponding points on the corrected characteristic

$G_1$  : Irradiance measured with the reference device

$G_2$  : Irradiance at the standard or other desired irradiance

$T_1$  : Temperature of the test specimen

$T_2$  : Standard or other desired temperature

$V_{oc1}$  : open circuit voltage at test conditions

$\alpha_{rel}, \beta_{rel}$  : Current and voltage temperature coefficients of the test specimen measured at 1000W/m<sup>2</sup>

$a$  : Irradiance correction factor

$R'_s$  : Internal series resistance of the test specimen

$K'$  : Temperature coefficient of the internal series resistance  $R'_s$ .

### 5.2.3 Correction procedure 3

This procedure is based on the linear interpolation of two measured I-V characteristics. It uses a minimum of two I-V characteristics, and requires no correction parameters or fitting parameters.

The measured current-voltage characteristics shall be corrected to standard test conditions or other selected temperature and irradiance values by applying the following equations:

$$V_3 = V_1 + \alpha(V_2 - V_1) \quad \dots(5.5)$$

$$I_3 = I_1 + \alpha(I_2 - I_1) \quad \dots(5.6)$$

The pair of  $(I_1, V_1)$  and  $(I_2, V_2)$  should be chosen so that

$$I_2 - I_1 = I_{sc2} - I_{sc1} \quad \dots(5.7)$$

where:

$I_1, V_1$ : Coordinates of points on the measured characteristics at an irradiance  $G_1$  and  $T_1$

$I_2, V_2$ : Coordinates of points on the measured characteristics at an irradiance  $G_2$  and  $T_2$

$I_3, V_3$ : Coordinates of points on the corrected characteristics at an irradiance  $G_3$  and  $T_3$

$I_{sc1}$  and  $I_{sc2}$ : Measured short-circuit current of the test specimen at irradiance  $G_1$  and  $G_3$  respectively

$\alpha$ : Constant of the interpolation, which has the relation with the irradiance and temperature as given below.

$$G_3 = G_1 + \alpha(G_2 - G_1) \quad \dots(5.8)$$

$$T_3 = T_1 + \alpha(T_2 - T_1) \quad \dots(5.9)$$

Figure 5.1 (a) and (b) show irradiance corrections, (c) shows a temperature correction, and (d) shows simultaneous correction of irradiance and temperature using Procedure 3.

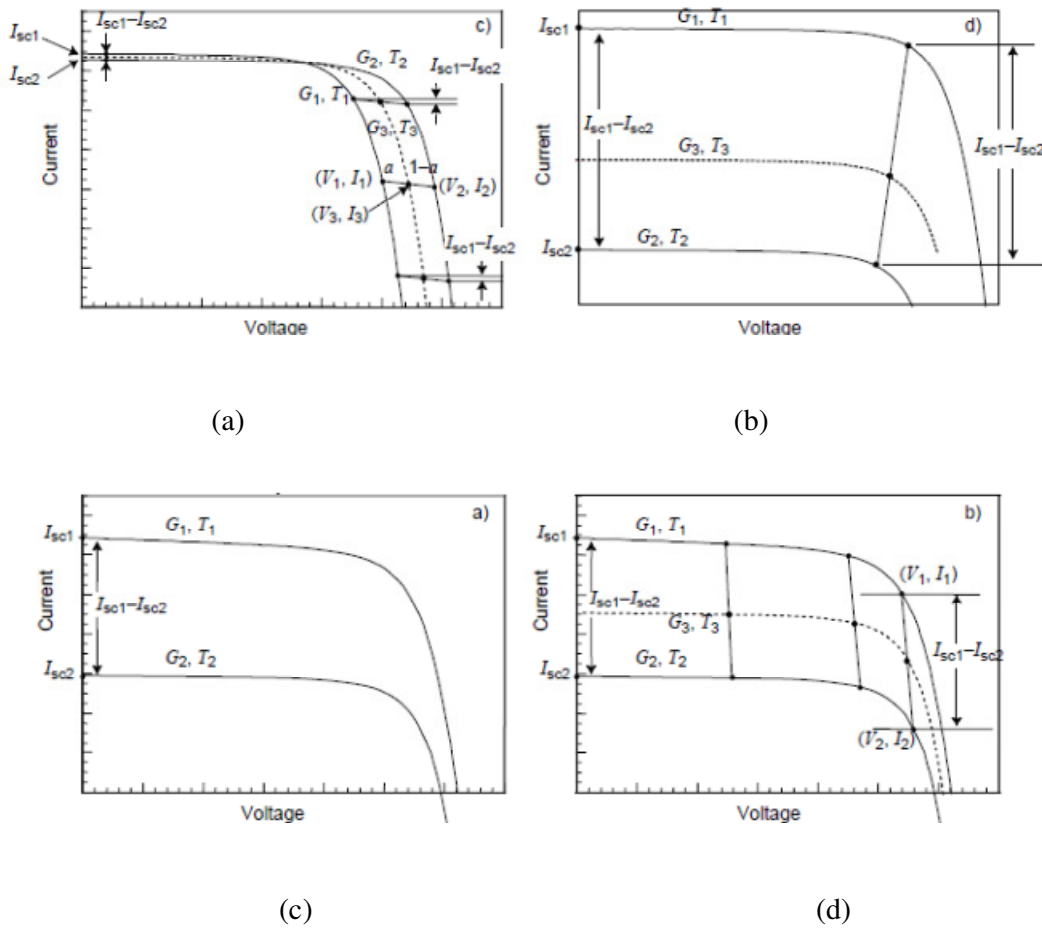

Fig. 5.1: (a) and (b) show irradiance corrections, (c) shows a temperature correction, and (d) shows simultaneous correction of irradiance and temperature using Procedure 3.

### 5.3 Correction Procedure Adopted for Survey Data

IEC correction procedure 1 was adapted for translating the survey data to the STC condition. As stated in the above equations we can see that correction procedure 1 involves four correction parameters for translating the entire curve. There is always a trade-off between accuracy of the corrected results and the complexity of the correction. It can be stated that correction procedures that promise to get along with only temperature coefficients for  $I_{sc}$  and  $V_{oc}$  will generally not reach the accuracy of procedures with more parameters. The challenge with more parameters is that their determination requires measurements of temperature and irradiance dependency.

5.3.1 Correction Procedure 1a

IEC Correction Procedure 1 involves four correction parameters ( $\alpha$ ,  $\beta$ ,  $R_s$  and  $k$ ) for the translation as stated above. In order to determine the value of  $R_s$  of a module, we require three I-V curves at constant temperature but different irradiances, whereas for the determination of  $k$ , we require three I-V curves at constant irradiance but different temperatures. If enough field data is not available to calculate  $R_s$  and  $k$ , one may considered only two parameters i.e.  $\alpha$  (temperature coefficient for current) and  $\beta$  (temperature coefficient for voltage) while keeping  $R_s$  and  $k$  equal to zero. This approximation has also been followed by researchers at TUV Rheinland for analyzing the data from the 1000 Rooftop’s program of Germany and they have reported a translation accuracy of 4% [6]. So, the equations of Correction Procedure 1 will get modified as follows:

$$I_2 = I_1 + I_{sc} * \left(\frac{G_2}{G_1} - 1\right) + \alpha * (T_2 - T_1) \quad \dots(5.10)$$

$$V_2 = V_1 + \beta(T_2 - T_1) \quad \dots(5.11)$$

We have used above two equations for correcting the measured I-V curve to the STC condition. We have named this procedure as correction Procedure 1a.

In order to understand the level of accuracy of correction Procedure 1a, we selected three c-Si modules at Solar Energy Centre Gurgaon, and measured their I-V data in the field using the automatic I-V tracer. The data so collected was translated to STC using Procedure 1a. Then these modules were taken back into the laboratory and tested in a solar simulator at STC conditions. These two sets of data of  $P_{max}$  (one set translated to STC from field data using Procedure 1a and another set measured at STC inside the laboratory) are compared in Table 5.1.

**Table 5.1: Comparison of  $P_{max}$ , obtained by Procedure 1a and measured in Solar Simulator**

	<b>Translated <math>P_{max}</math> (Watts) (Using Procedure 1a)</b>	<b><math>P_{max}</math> (Watts) measured in laboratory at SEC</b>
<b>Module 1</b>	64.4	61.7
<b>Module 2</b>	64.2	63.2
<b>Module 3</b>	64.6	66.3

### 5.3.2 Low irradiance correction

As IEC 60891 translation procedures can be applied only for 20% variation in the irradiance, irradiance should not be below  $800 \text{ W/m}^2$  for translation to STC. During our survey, due to the overcast weather at some sites, the I-V data were measured at irradiance around  $550 \text{ W/m}^2$  for some modules. However, we would like that even such I-V curves be translated to STC in order to facilitate the performance comparison and degradation analysis of different modules. So it was required to know the error in translating I-V data measured at irradiance above  $550 \text{ W/m}^2$  to STC using Procedure 1a.

In order to assess this error, we measured modules of different technologies (crystalline silicon (c-Si), CIGS, and amorphous silicon (a-Si)) which are on the test bed of IIT Bombay PV module monitoring station. I-V data of these modules were recorded at different times of the day by an automatic I-V tracer so as to capture the I-V data at different irradiance levels. These I-V data were then corrected to STC by using Procedure 1a. This exercise was repeated for modules of the different technologies mentioned above.

Thus from the corrected I-V data using Procedure 1a, error in the value of  $P_{max}$  was calculated and plotted at different irradiances for different technology. Figure 5.2 shows the error in  $P_{max}$  at different irradiances for mono c-Si, Fig. 5.3 for multi c-Si, Fig. 5.4 for a-Si, and Fig. 5.5 for CIGS.

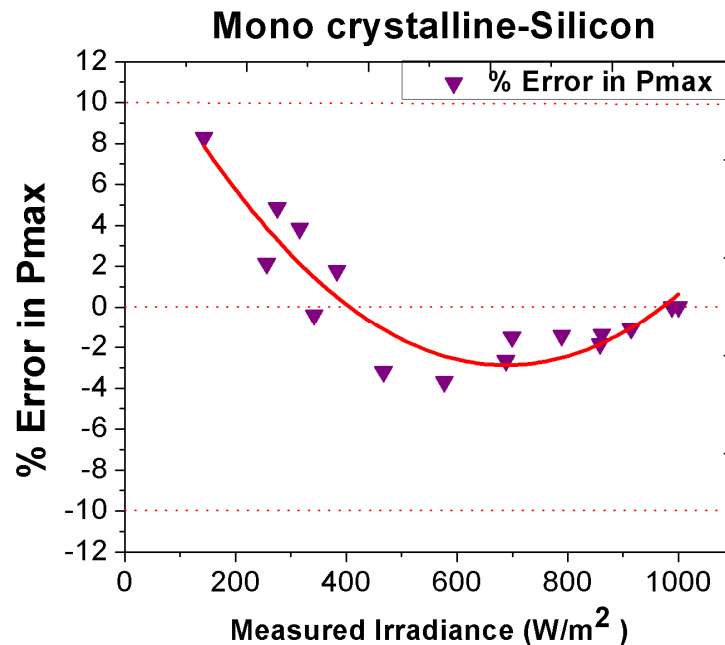

Fig. 5.2: Error in  $P_{max}$  at different irradiances for Mono c-Si

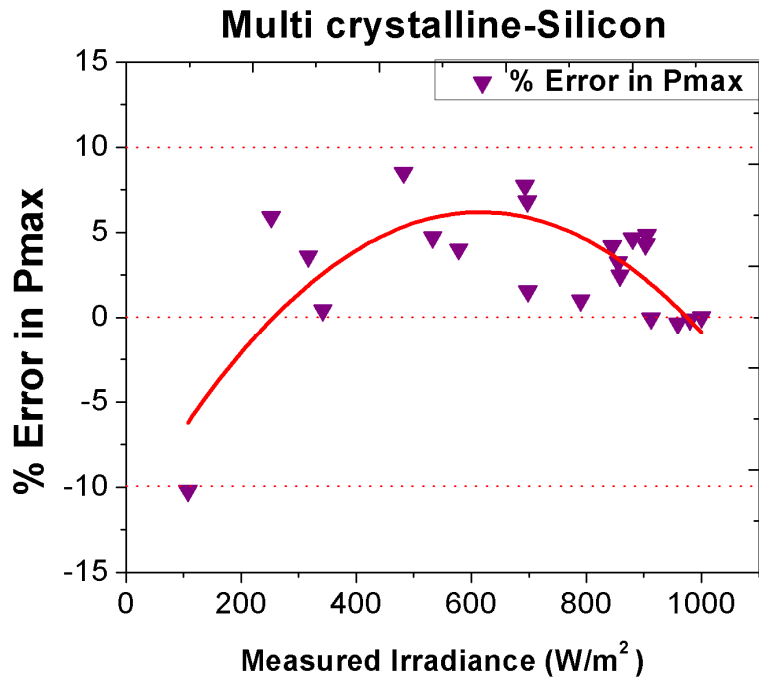

Fig. 5.3: Error in  $P_{max}$  at different irradiances for Multi c-Si

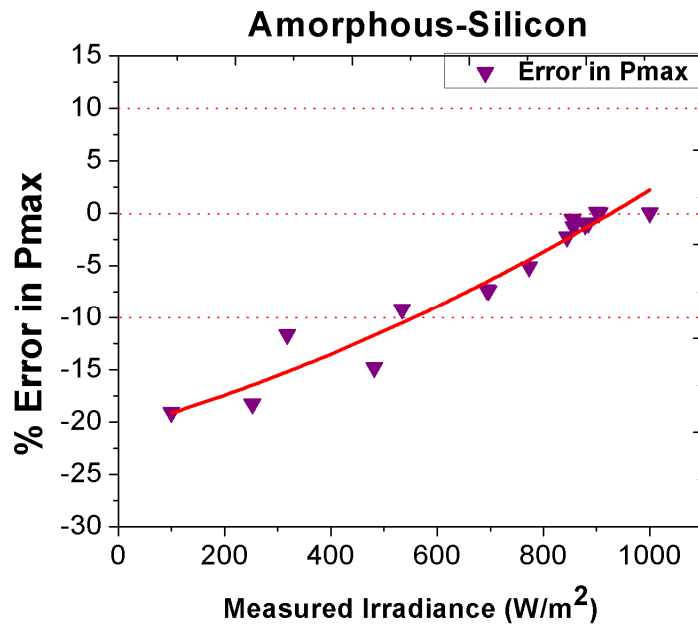

Fig. 5.4: Error in  $P_{max}$  at different irradiances for a-Si

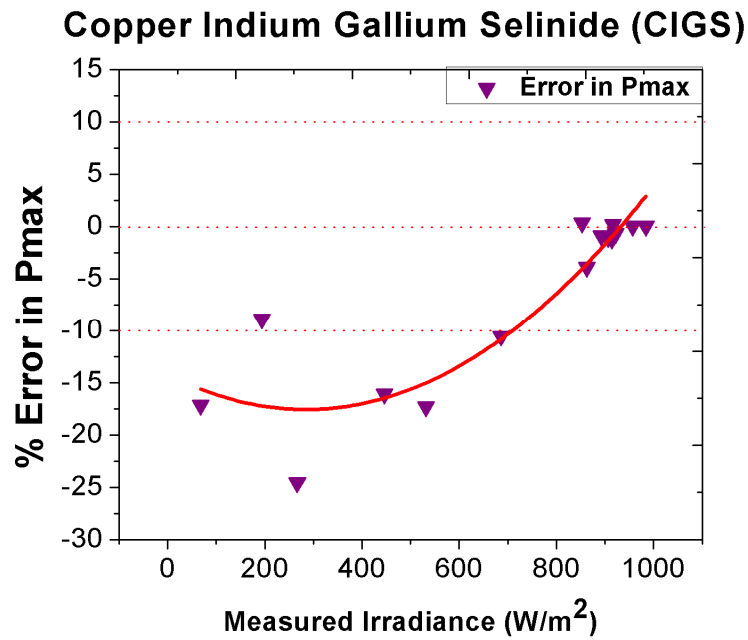

Fig. 5.5: Error in  $P_{max}$  at different irradiances for CIGS

Table 5.2 shows the maximum error in  $P_{max}$  translation from irradiance of 550 W/m<sup>2</sup> or above, for the different PV module technologies.

**Table 5.2: Maximum Error in  $P_{max}$  Translation using Procedure 1a**

Technology	Maximum Percentage Error in $P_{max}$ for Irradiance above 550 W/m <sup>2</sup>
Mono crystalline Silicon	4
Multi crystalline Silicon	7.5
Amorphous Silicon	14
Copper Indium Gallium Selenide (CIGS)	18

Hence we can conclude that the error in translation (using Procedure 1a) from irradiance of 550 W/m<sup>2</sup> or above is within 10% for crystalline silicon technology and within 20% for thin film technologies. This important experiment and conclusion allows us to use data obtained at irradiance levels above 550 W/m<sup>2</sup> with reasonable accuracy.

## 5.4 Software Package for STC Correction

The STC correction for the measured I-V data was done by using Procedure 1a correction procedure. A MATLAB code was written in order to do the correction of the measured I-V data. It uses the equations of the Procedure 1a. The step by step process of the I-V data correction by using MATLAB code is given in Appendix I.

## 5.5 Choice of Using the Median versus the Mean

From the mass of data collected in our survey, we need to present overall trends in the measurements. For this, we could use the mean of various parameters, or alternatively the median. In this section, we discuss the choice of mean versus median. In any set of data, there will always be some outliers (data points that lie towards the extreme end of the range). These extreme values are usually in the minority as compared to the rest of the data set. The outliers tend to affect the mean value of the data set significantly, which may lead to wrong conclusions with the regard to the normal behavior. However, the median value is not much affected by these outliers and can be taken to be representative of the average behavior of the majority in the data set. It seems reasonable for our case to take the median instead of the mean. This is substantiated by an analysis of some of the data as described below.

We know that the maximum power  $P_{max}$  is given by the following relation:

$$P_{max} = V_{oc} * I_{sc} * FF \quad \dots(5.12)$$

The error in  $P_{max}$  (represented by  $\Delta P_{max}$ ) can be obtained from the errors in Voc, Isc and FF using the relation:

$$\Delta P_{max} = \Delta V_{oc} * I_{sc} * FF + V_{oc} * \Delta I_{sc} * FF + V_{oc} * I_{sc} * \Delta FF \quad \dots(5.13)$$

$$\frac{\Delta P_{max}}{P_{max}} = \frac{\Delta V_{oc} * I_{sc} * FF}{P_{max}} + \frac{V_{oc} * \Delta I_{sc} * FF}{P_{max}} + \frac{V_{oc} * I_{sc} * \Delta FF}{P_{max}} \quad \dots(5.14)$$

Hence,

$$\frac{\Delta P_{max}}{P_{max}} = \frac{\Delta V_{oc}}{V_{oc}} + \frac{\Delta I_{sc}}{I_{sc}} + \frac{\Delta FF}{FF} \quad \dots(5.15)$$

Fig. 5.6 plots the relative error in  $P_{max}$  (i.e.  $\Delta P_{max} / P_{max}$ ) against the sum of relative errors of  $V_{oc}$ ,  $I_{sc}$  and  $FF$ , for multi-c Si modules. Since majority of the data points are located close to the solid red line having slope equal to 1, we can conclude that our field data is satisfying the theoretical relation obtained above.

However if we look at the sum of the mean values of the  $V_{oc}$ ,  $I_{sc}$  and  $FF$  degradation rates ( $0.53+0.1+1.0=1.63$ ) in Fig.5.7 we find that they do not add up to mean value of  $P_{max}$  degradation rate (1.73). On the other hand the sum of the median values of  $V_{oc}$ ,  $I_{sc}$  and  $FF$  degradation rates ( $0.83+0.2+0.37=1.40$ ) nearly matches the median value of  $P_{max}$  degradation rate (1.41). This demonstrates that median is a better representative of the overall behavior of our survey data. Moreover during discussion with the authors of [8] they have also supported the use of median for our data set. Accordingly, we have chosen to use the median value as representative of the data set.

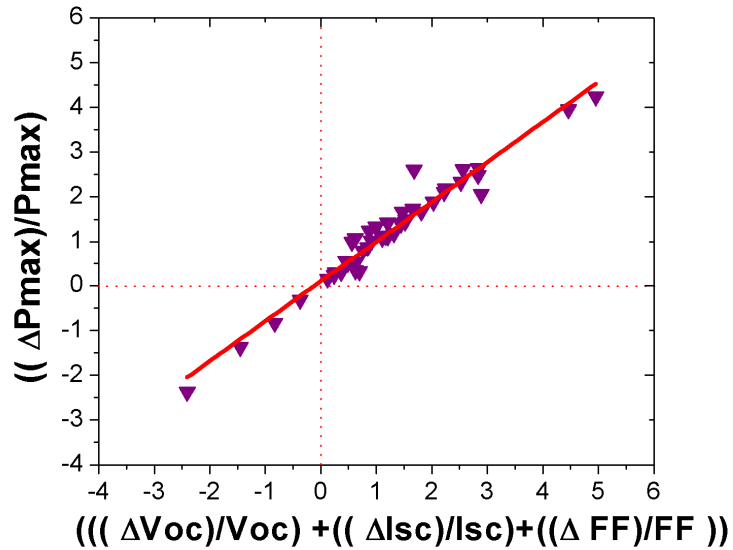

Fig. 5.6: Correlation between percentage changes in  $P_{max}$  vs. sum of percentage change in  $V_{oc}$ ,  $I_{sc}$  and  $FF$

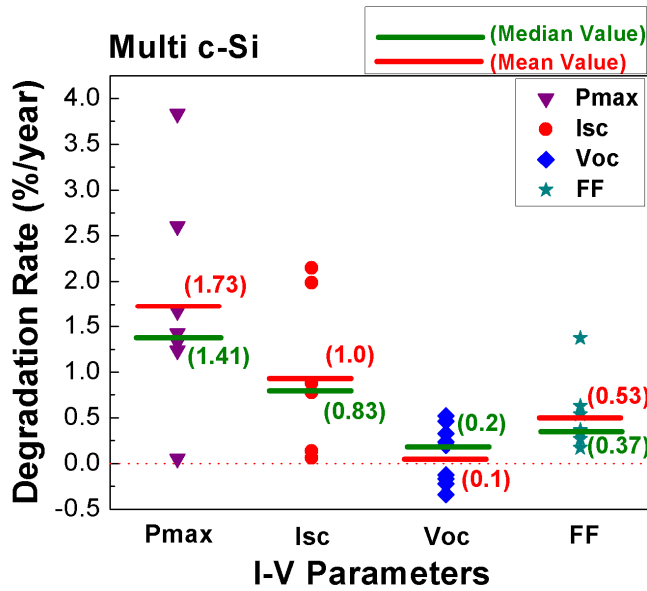

Fig. 5.7: Degradation rates of IV parameters showing both the Median and Mean values

### 5.6 Uncertainty in Degradation Rate Calculation

The electrical parameters at STC are derived from measurement and correction. Therefore the uncertainty (or error bars) in the STC data is composed of the actual measurement uncertainties introduced by the equipment plus the uncertainties of the correction procedure (refer Fig .5.8).

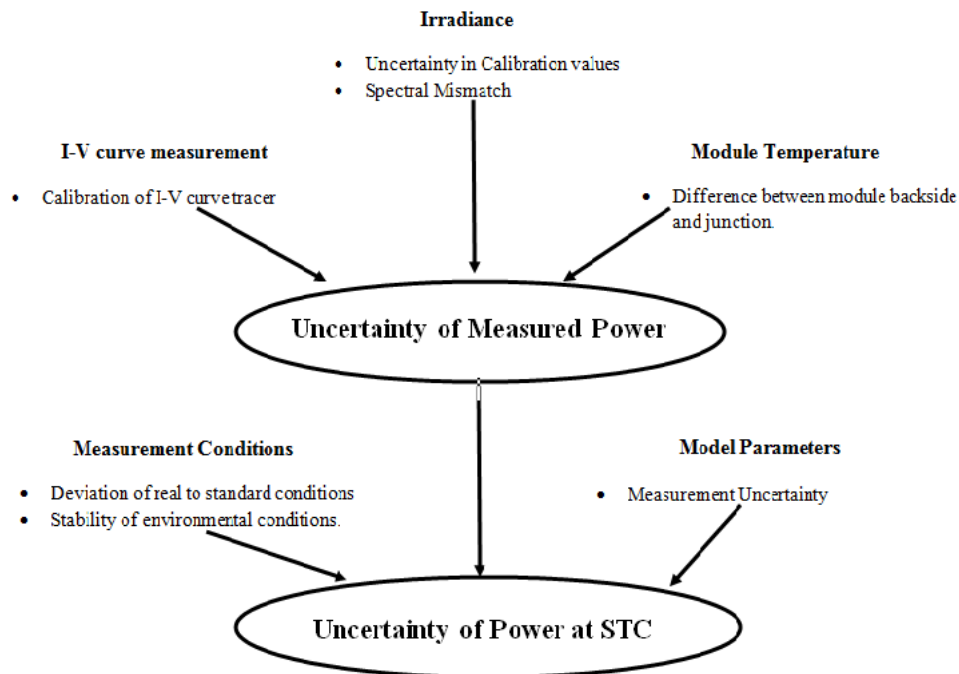

Fig. 5.8: Major influences on the combined uncertainty of power at STC [7]

### 5.6.1 Uncertainties in measurements

The field I-V curve measurement system (Solar System Analyzer manufactured by MECO) has a resistance temperature detector as the temperature sensor. The irradiance sensor is a crystalline silicon reference cell.

The standard uncertainties of measured irradiance are calibration value, stability, temperature coefficient, data acquisition and spectral mismatch. Resulting combined uncertainty in the irradiance measurement is 3%, as per the manufacturer datasheet.

The standard uncertainty of module measured temperature is the difference between sensor and module sheet temperature and temperature in-homogeneity in the module. Resulting combined uncertainty in the temperature measurement is 1%, as per the manufacturer datasheet.

The manufacturer datasheet specifies the maximum measurement uncertainty in both voltage and current as 1%.

### 5.6.2 Uncertainties in correction procedure

It is basically composed of the accuracy of the correction procedure used. Generally, the closer the real conditions are to STC (1000 W/m<sup>2</sup>. and 25 deg. C) during measurement, the less is the uncertainty introduced by the correction. We have performed an experiment in order to find out the influence of module temperature on the error in corrected  $P_{max}$ . We have cooled a PV module by pouring water on the glass surface. Then we have exposed this module to sunlight and started recording the module I-V data at 1 minute intervals. The I-V data was collected for a period of 15 minutes, during which the irradiance was practically constant whereas the temperature of the module increased from 32 deg. C to 53 deg. C. These I-V data were translated to STC by Procedure 1a and the errors in translated  $P_{max}$  were computed. The results are shown in Fig. 5.9, which indicates that the percentage error in  $P_{max}$  at STC increases with increase in temperature. Thus higher the temperature deviation from STC, the more influence from temperature coefficients in the correction.

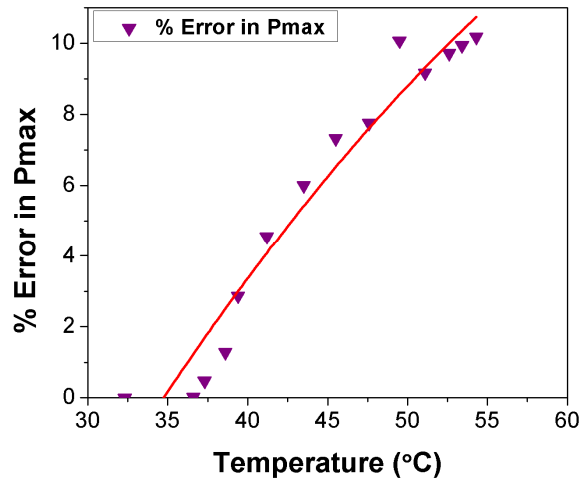

Fig. 5.9: Percentage Error in  $P_{max}$  at STC vs. temperature.

### 5.6.3 Uncertainties in power at STC

As evident from the discussion so far, the uncertainty in the corrected Power is due to uncertainties in the measurement of the I-V data, temperature and irradiance in the field, and also due to the uncertainties in the temperature coefficients which are used in the translation equations (refer Fig. 5.10). Table 5.3 and table 5.4 shows that the worst case error in the corrected  $P_{max}$  will be 24% for CIGS modules. However, majority of the surveyed modules were crystalline silicon, for which the maximum possible error is 13.5%. For calculating the  $P_{max}$  degradation rate, we have used the Name Plate rating of the PV module, and this rating also usually has a tolerance band of around 5%, which will also introduce some error in the  $P_{max}$  degradation rate.

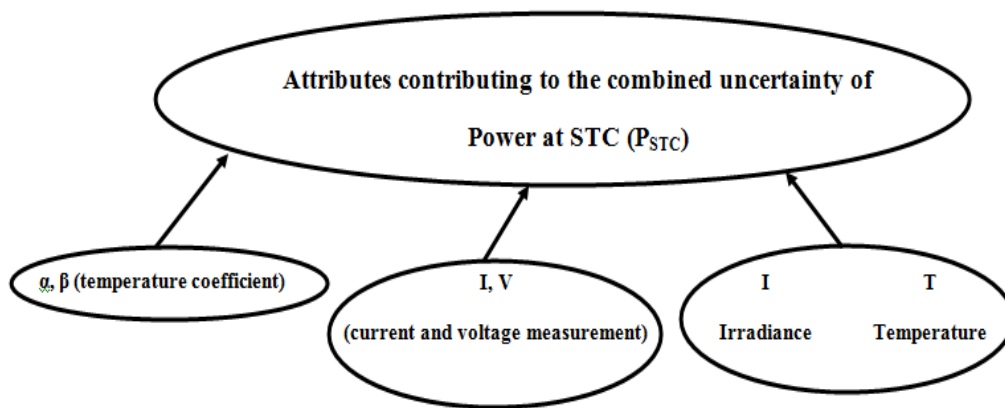

Fig. 5.10: The contributors to the combined uncertainty of power at STC [7]

**Table 5.3: Maximum Percentage Error in corrected  $P_{max}$  at STC for measured irradiance greater than 550 W/m<sup>2</sup> and temperature less than 65 °C**

Technology	Percentage Error introduced by					Total Error (%) in Pmax
	Instrument				Procedure 1a	
	Irradiance	Temperature	Voltage	Current	Irradiance (>550 W/m <sup>2</sup> ) Temperature (<65 °C)	
Mono c-Si	3	1	1	1	4	10
Multi c- Si	3	1	1	1	7.5	13.5
a-Si	3	1	1	1	14	20
CIGS	3	1	1	1	18	24

**Table 5.4: Maximum Percentage Error in corrected  $P_{max}$  at STC for measured irradiance greater than 800 W/m<sup>2</sup> and temperature less than 65 °C**

Technology	Percentage Error introduced by					Total Error (%) in Pmax
	Instrument				Procedure 1a	
	Irradiance	Temperature	Voltage	Current	Irradiance (>800 W/m <sup>2</sup> ) Temperature (<65 °C)	
Mono c-Si	3	1	1	1	2	8
Multi c- Si	3	1	1	1	4.5	10.5
a-Si	3	1	1	1	5	11
CIGS	3	1	1	1	8	14

## 5.7 Conclusion

We have examined various correction procedures available in the literature, and decided to use a modified version of IEC 60891 correction procedure1 (referred to as Procedure 1a) for translating the field I-V data to the STC condition. A MATLAB program has been developed to implement this procedure, and that has been described in this chapter. We have also decided to use the median rather than mean of the data for the analysis of data, as presented in subsequent chapters. Finally, we have assessed the uncertainty in the data by estimating the errors of measurement as well as in STC correction. The maximum error introduced in translating the  $P_{max}$  value to STC is within 13.5% for c-Si modules for IV data measured above  $550 \text{ W/m}^2$  by using Procedure 1a. Using the Procedure 1a described in this chapter, we were able to obtain STC data of all modules surveyed, and these data formed the basis for analysis of effect of climatic zone and technology, as described in the next few chapters.

## 6. Information on Modules Surveyed

---

### 6.1 Introduction

A total of 63 modules were inspected during the survey. This chapter gives the site locations, as well as the distribution and histograms of these 63 modules under various classification schemes, such as technology of modules, age of modules, power ratings, climatic zone in which installed, type of packaging, etc. This provides a broad overview of the location, range and diversity of the modules surveyed.

### 6.2 Details of Sites Surveyed

The survey encompassed a total of 26 sites from Kerala to Ladakh, and from Rajasthan to West Bengal, covering 5 climatic zones (Hot & Dry, Hot and Humid, Temperate, Composite and Cold). The details of these sites are presented in Table 6.1. It gives the location (including latitude and longitude), the date of visit, the climatic zone under which the site falls, and the type and number of modules tested at this site. It also includes a representative photograph of the modules at the site. Further details of all 63 modules at each of the 26 sites are given in Appendix III.

ALL INDIA SURVEY ON PV MODULE DEGRADATION: 2013

**Table 6.1: Description of the 26 sites surveyed**

<p>DATE OF VISIT : 8 May 2013</p> <p>LOCATION : Kochi (9.96 N, 76.21 E)</p> <p>TYPE OF MODULES SURVEYED (Nos.): Multi c-Si (1)</p>  <p>SITE NO. : 1</p> <p>CLIMATE : Hot &amp; Humid</p> <p>YEAR OF INSTALLATION: 2006</p>	<p>DATE OF VISIT : 9 May 2013</p> <p>LOCATION : Kochi (9.96 N, 76.21 E )</p> <p>TYPE OF MODULES SURVEYED (Nos.) : Multi-junction a-Si (1)</p>  <p>SITE NO. : 2</p> <p>CLIMATE : Hot &amp; Humid</p> <p>YEAR OF INSTALLATION: 2012</p>
<p>DATE OF VISIT : 10 May 2013</p> <p>LOCATION : Kochi (9.96 N, 76.21 E )</p> <p>TYPE OF MODULES SURVEYED (Nos.) : Multi c-Si (1)</p>  <p>SITE NO. : 3</p> <p>CLIMATE : Hot &amp; Humid</p> <p>YEAR OF INSTALLATION: 2002</p>	<p>DATE OF VISIT : 12 May 2013</p> <p>LOCATION : Puducherry (11.93 N,79.83 E)</p> <p>TYPE OF MODULES SURVEYED (Nos.) : Mono c-Si (6)</p>  <p>SITE NO. : 4</p> <p>CLIMATE : Hot &amp; Humid</p> <p>YEAR OF INSTALLATION: 1984, 1995 (4 nos.), 1997</p>

ALL INDIA SURVEY OF PV MODULE DEGRADATION: 2013

<p>DATE OF VISIT : 13 May 2013</p> <p>LOCATION: Puducherry (11.93 N,79.83 E)</p> <p>TYPE OF MODULES SURVEYED (Nos.) : Mono c-Si (4)</p> 	<p>SITE NO. : 5</p> <p>CLIMATE: Hot &amp; Humid</p> <p>YEAR OF INSTALLATION: 1995(2 nos.), 2000, 2007</p>	<p>DATE OF VISIT : 13 May 2013</p> <p>LOCATION : Puducherry (11.93 N,79.83 E)</p> <p>TYPE OF MODULES SURVEYED (Nos.) : Mono c-Si (1)</p> 	<p>SITE NO. : 6</p> <p>CLIMATE : Hot &amp; Humid</p> <p>YEAR OF INSTALLATION: 2000</p>
<p>DATE OF VISIT : 14 May 2013</p> <p>LOCATION : Chennai (13.08 N, 80.27 E)</p> <p>TYPE OF MODULES SURVEYED (Nos.) : Mono c-Si (7)</p> 	<p>SITE NO. : 7</p> <p>CLIMATE: Hot &amp; Humid</p> <p>YEAR OF INSTALLATION: 1997(3 nos.), 2005, 2008 (3 nos.)</p>	<p>DATE OF VISIT : 16 May 2013</p> <p>LOCATION : Bangalore (12.98 N,77.58 E)</p> <p>TYPE OF MODULES SURVEYED (Nos.) : Mono c-Si (1)</p> 	<p>SITE NO. : 8</p> <p>CLIMATE : Temperate</p> <p>YEAR OF INSTALLATION: 1998</p>

ALL INDIA SURVEY OF PV MODULE DEGRADATION: 2013

<p>DATE OF VISIT : 16 May 2013</p> <p>LOCATION: Bangalore (12.98 N,77.58 E)</p> <p>TYPE OF MODULES SURVEYED (Nos.) : Multi c-Si (1)</p>  <p>YEAR OF INSTALLATION: 2007</p>	<p>SITE NO. : 9</p> <p>CLIMATE: Temperate</p> <p>DATE OF VISIT : 20 May 2013</p> <p>LOCATION :Pune (18.52 N,73.84 E)</p> <p>TYPE OF MODULES SURVEYED (Nos.) : Multi c-Si (1)</p>  <p>YEAR OF INSTALLATION: 2010</p> <p>SITE NO. : 10</p> <p>CLIMATE : Hot &amp; Humid</p>
<p>DATE OF VISIT : 20 May 2013</p> <p>LOCATION : Pune (18.52 N,73.84 E)</p> <p>TYPE OF MODULES SURVEYED (Nos.) : Multi c-Si (1)</p>  <p>YEAR OF INSTALLATION: 2009</p>	<p>DATE OF VISIT : 20 May 2013</p> <p>LOCATION : Pune (18.52 N,73.84 E)</p> <p>TYPE OF MODULES SURVEYED (Nos.) : CIGS (1)</p>  <p>YEAR OF INSTALLATION: 2009</p> <p>SITE NO. : 11</p> <p>CLIMATE: Hot &amp; Humid</p> <p>DATE OF VISIT : 20 May 2013</p> <p>LOCATION : Pune (18.52 N,73.84 E)</p> <p>CLIMATE: Hot &amp; Humid</p> <p>SITE NO. : 12</p>





ALL INDIA SURVEY OF PV MODULE DEGRADATION: 2013

<p>DATE OF VISIT : 26 May 2013</p> <p>LOCATION: Sagar Island (21.94 N, 88.8 E)</p> <p>TYPE OF MODULES SURVEYED (Nos.) : Mono c-Si (3)</p>  <p>YEAR OF INSTALLATION: 1998</p>	<p>DATE OF VISIT : 27 May 2013</p> <p>LOCATION: Sagar Island (21.94 N, 88.8 E)</p> <p>TYPE OF MODULES SURVEYED (Nos.) : Mono c-Si (1)</p>  <p>YEAR OF INSTALLATION: 1996</p>
<p>DATE OF VISIT : 27 May 2013</p> <p>LOCATION: Sagar Island (21.94 N, 88.8E)</p> <p>TYPE OF MODULES SURVEYED (Nos.) : Multi c-Si (1)</p>  <p>YEAR OF INSTALLATION: 2002</p>	<p>DATE OF VISIT : 27 May 2013</p> <p>LOCATION: Sagar Island (21.94 N, 88.8 E)</p> <p>TYPE OF MODULES SURVEYED (Nos.) : Mono c-Si (1)</p>  <p>YEAR OF INSTALLATION: 2002</p>

ALL INDIA SURVEY OF PV MODULE DEGRADATION: 2013

<p>DATE OF VISIT : 27 May 2013</p> <p>LOCATION: Sagar Island (21.94 N, 88.8 E)</p> <p>TYPE OF MODULES SURVEYED (Nos.) : Mono c-Si (1)</p>  <p>YEAR OF INSTALLATION: 1995</p>	<p>SITE NO. : 17</p> <p>CLIMATE : Hot &amp; Humid</p> <p>DATE OF VISIT : 27 May 2013</p> <p>LOCATION: Sagar Island (21.94 N, 88.8 E)</p> <p>TYPE OF MODULES SURVEYED (Nos.) : Mono c-Si (1)</p>  <p>YEAR OF INSTALLATION: 1988</p>
<p>DATE OF VISIT : 30 May 2013</p> <p>LOCATION: Patna (25.08 N, 85.27E)</p> <p>TYPE OF MODULES SURVEYED (Nos.) : Multi c-Si (2)</p>  <p>YEAR OF INSTALLATION: 1998, 2008</p>	<p>SITE NO. : 19</p> <p>CLIMATE : Composite</p> <p>DATE OF VISIT : 30 May 2013</p> <p>LOCATION: Patna (25.08 N, 85.27E)</p> <p>TYPE OF MODULES SURVEYED (Nos.) : Multi c-Si (2)</p>  <p>YEAR OF INSTALLATION: 2011 (2 n)</p>

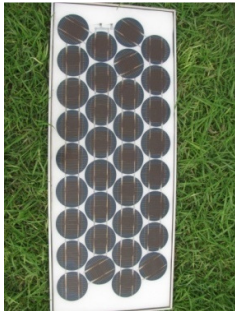
ALL INDIA SURVEY OF PV MODULE DEGRADATION: 2013

<p>DATE OF VISIT : 31 May 2013</p> <p>LOCATION: Patna (25.08 N, 85.27E)</p> <p>TYPE OF MODULES SURVEYED (Nos.) : Mono c-Si (2)</p>  <p>YEAR OF INSTALLATION: 2010 (2 nos.)</p>	<p>SITE NO. : 21</p> <p>CLIMATE : Composite</p> <p>DATE OF VISIT : 1 June 2013</p> <p>LOCATION: Gurgaon (28.47 N,77.03 E)</p> <p>TYPE OF MODULES SURVEYED (Nos.) : Mono c-Si (5), a-Si(3), CIGS(1)</p>  <p>YEAR OF INSTALLATION: 1999 (5 nos.), 2000 (2 nos.), 2002</p>
<p>DATE OF VISIT : 3 June 2013</p> <p>LOCATION: Gurgaon (28.47 N,77.03 E)</p> <p>TYPE OF MODULES SURVEYED (Nos.) : Mono c-Si (1)</p>  <p>YEAR OF INSTALLATION: 1988</p>	<p>SITE NO. : 23</p> <p>CLIMATE : Composite</p> <p>DATE OF VISIT : 5 June 2013</p> <p>LOCATION: Tilonia (26.65 N,74.95E)</p> <p>TYPE OF MODULES SURVEYED (Nos.) : Multi c-Si (1), Mono c-Si(5)</p>  <p>YEAR OF INSTALLATION: 1998, 2000 (3 nos.), 2007 (3 nos.)</p>

ALL INDIA SURVEY OF PV MODULE DEGRADATION: 2013

DATE OF VISIT : 6 June 2013

LOCATION: Tilonia (26.65 N,74.95E)

TYPE OF MODULES SURVEYED (Nos.) : Mono c-Si (4)



SITE NO. : 25

CLIMATE : Hot & Dry

YEAR OF INSTALLATION:  
1985, 1986(2 nos.), 2000

DATE OF VISIT : 12 June 2013

LOCATION: Hanle (32.77 N,78.96 E)

TYPE OF MODULES SURVEYED (Nos.) : Mono c-Si (3)



SITE NO. : 26

CLIMATE : Cold

YEAR OF INSTALLATION:  
1998 (3 nos.)

### 6.3 Histograms of Module Details

The survey data is summarized in Figs.6.1 through 6.8. Figure 6.1 shows the distribution of technology of the modules surveyed. Most of the modules inspected are mono-crystalline silicon modules, though we also had multi-crystalline silicon, amorphous silicon and CIGS modules. Figure 6.2 shows the histogram of the age of the modules, and it is seen that a majority of the modules (about 65%) fall in the age group of 11 to 20 years. Figure 7.3 shows that most of the modules have name-plate power ratings in the range of 30 Wp to 100 Wp (the most common wattage being 75 Wp, found in 46% cases in the survey). The maximum number of modules was surveyed in the Hot & Humid zone as evident from Fig.6.4, while some of the other zones like the Temperate zone and Cold zone were not as well represented. Figure 6.5 shows the biasing condition of the modules. Most of the modules had glass top cover with polymer backsheet, as evident from Fig.6.6. Almost all of the systems surveyed either had both battery and inverter, or none of the two (refer to Fig.6.7). Finally the panels were lightly soiled in most of the sites visited, as evident from Fig.6.8.

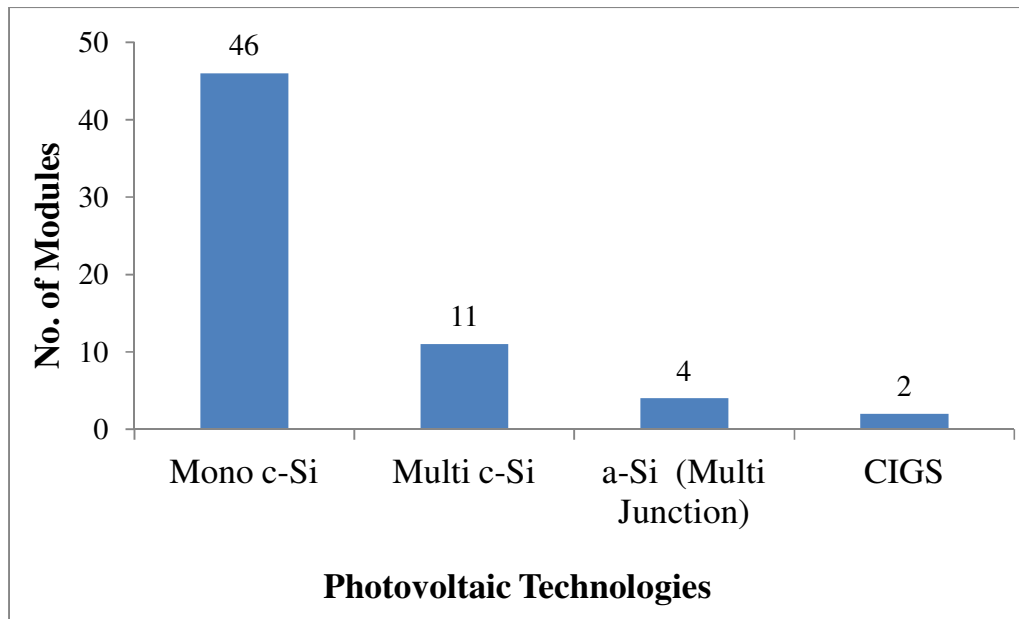

Fig. 6.1: Technology-wise distribution of inspected modules

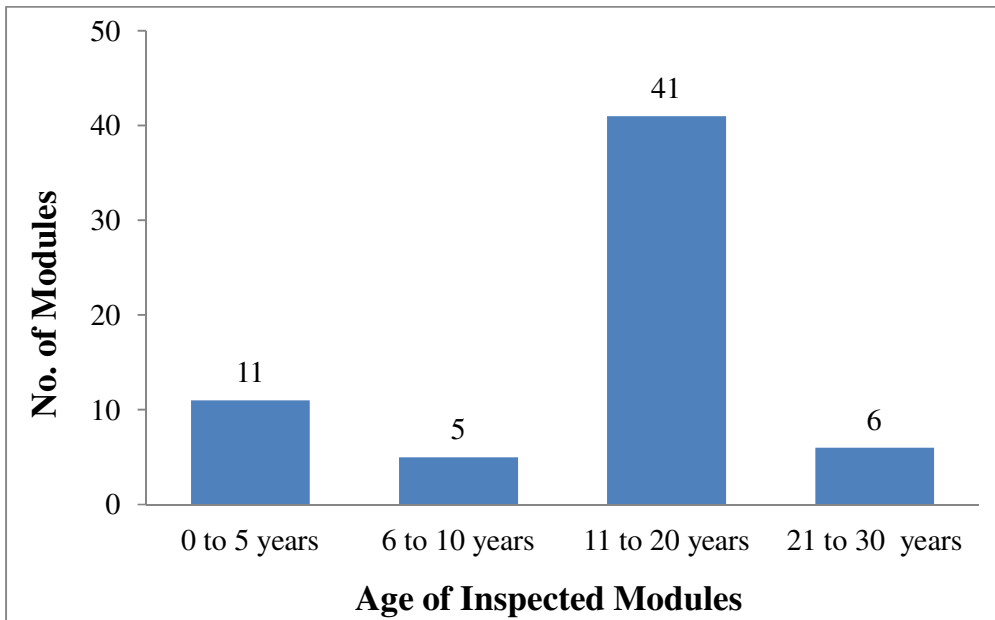

Fig. 6.2: Age-wise distribution of inspected modules

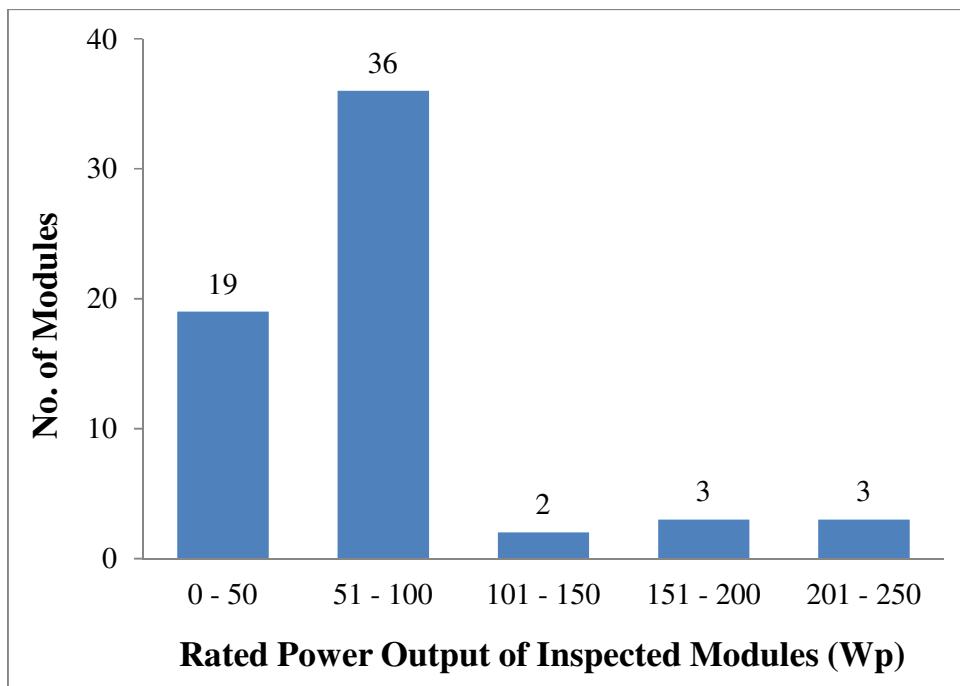

Fig. 6.3: Rated Power distribution of inspected modules

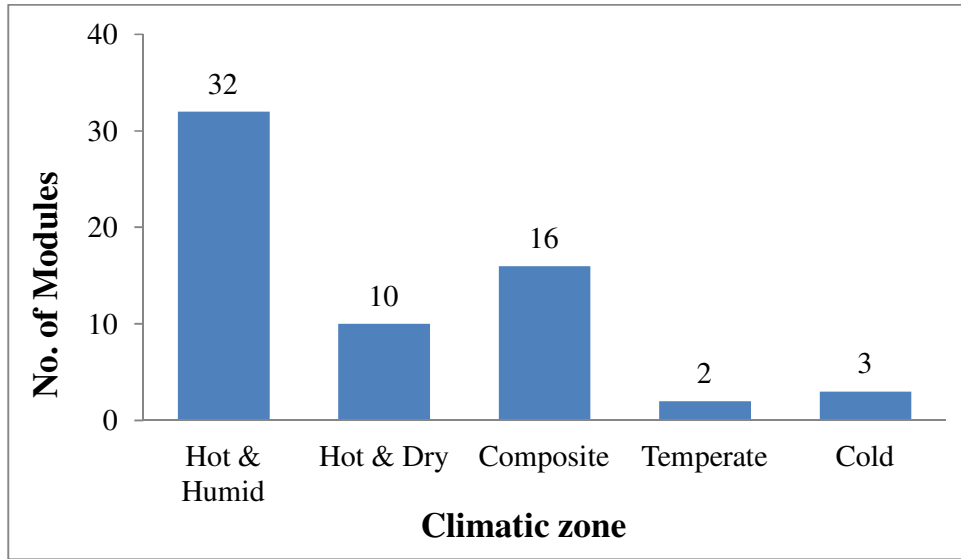

Fig. 6.4: Climatic zone-wise distribution of the modules

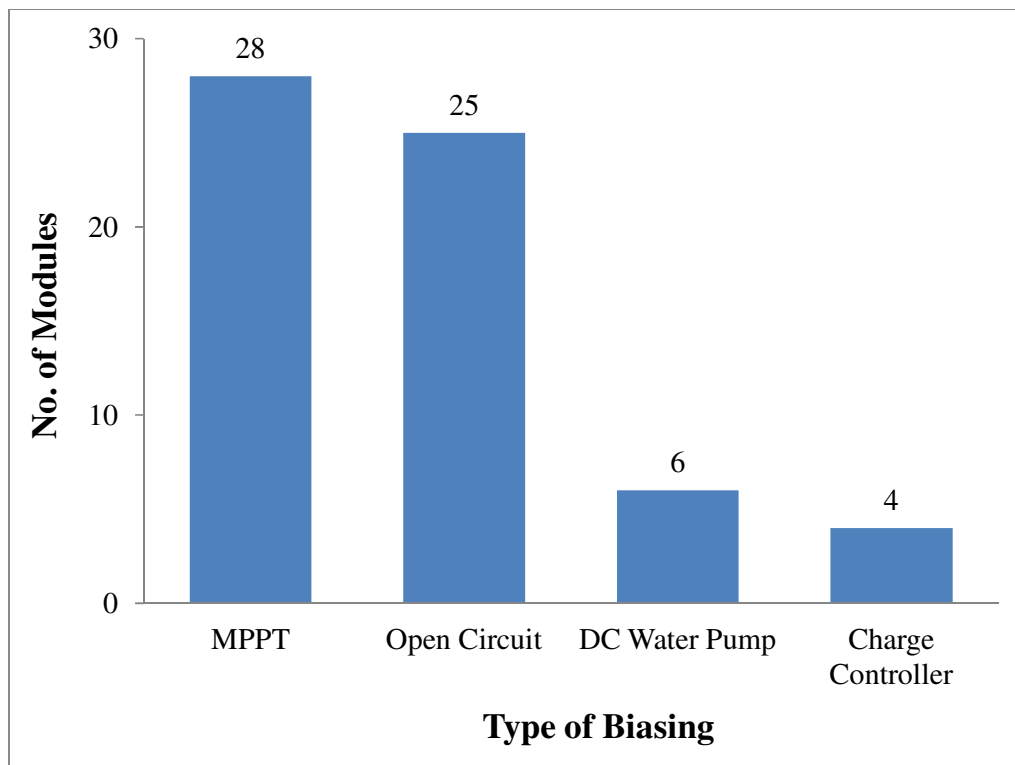

Fig. 6.5: Type of Biasing of the inspected modules

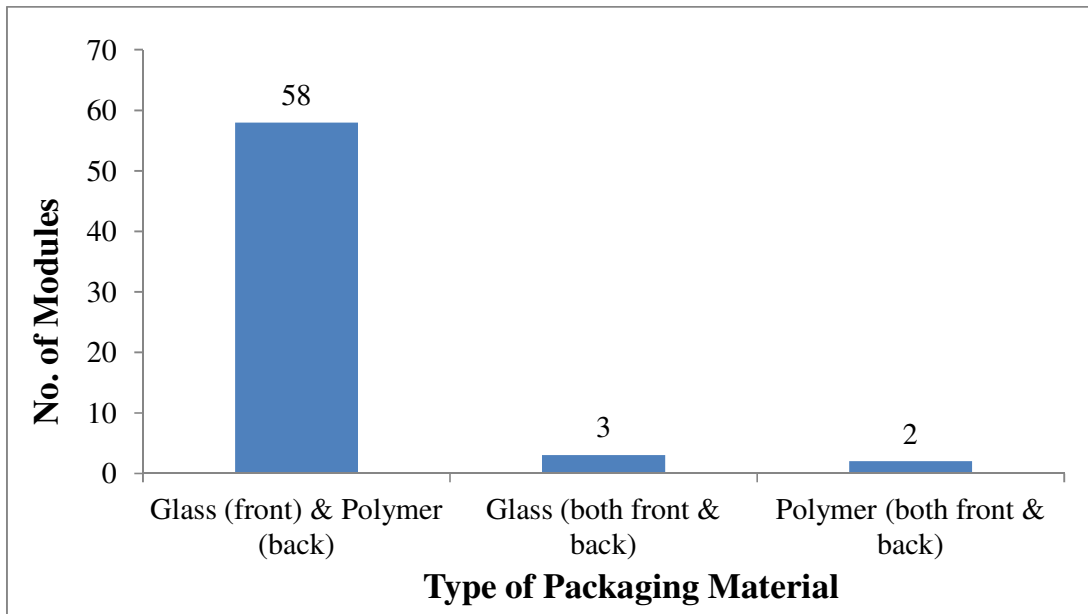

Fig. 6.6: Packaging material distribution of inspected modules

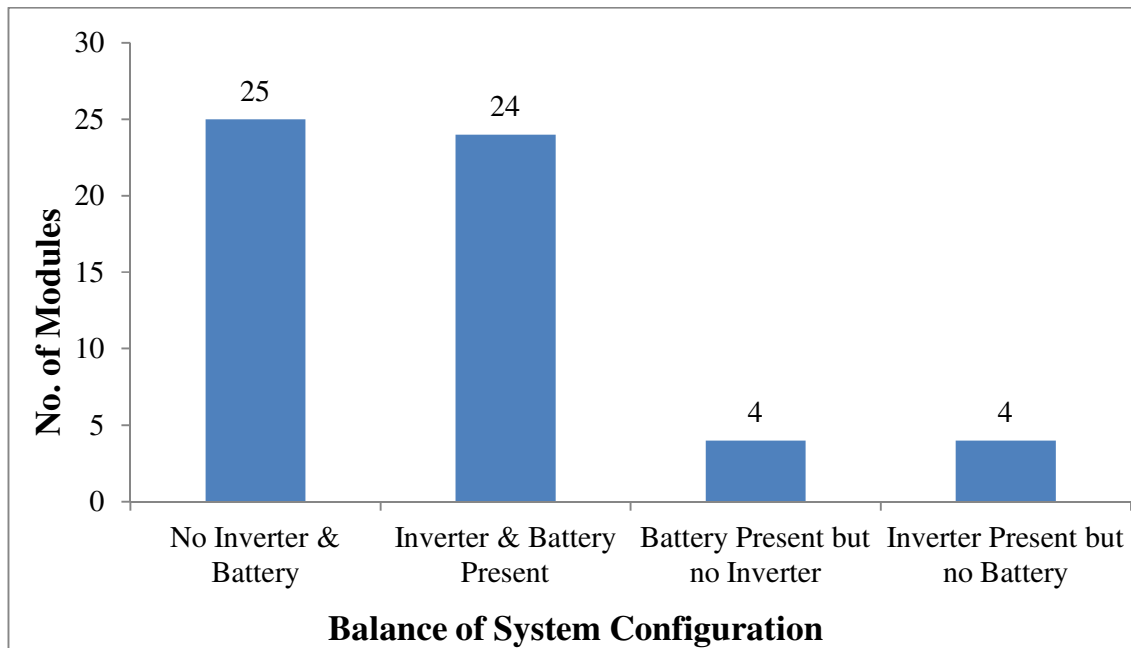

Fig. 6.7: Balance of System configuration

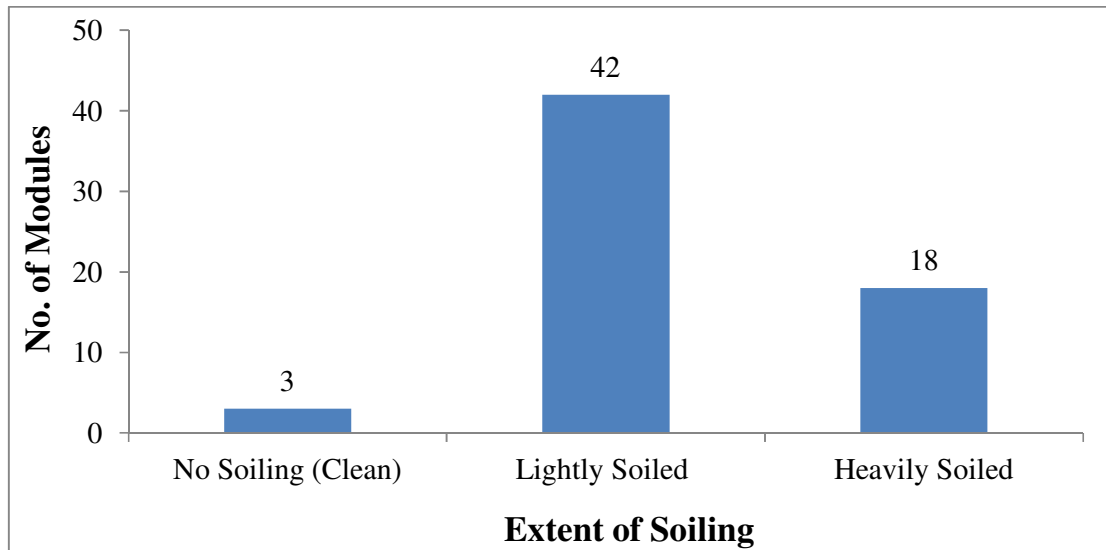

Fig. 6.8: Extent of soiling

## 6.4 Conclusion

In this chapter, we have first presented the details of the 26 sites visited during the All-India Survey. We have then presented histograms of the 63 modules surveyed according to various classification schemes. The next two chapters will focus on the detailed analysis of the electrical performance degradation observed in the modules, and the various visual degradation modes seen.



## 7. Analysis of Electrical degradation

---

### 7.1 Introduction

An accurate prediction on power delivery over the course of time is of vital importance for the deployment and growth of the photovoltaic industry. There are two key cost drivers. One is the efficiency with which the sunlight is converted into electrical power and the other is how this relationship is holding with respect to time. The parameter for the quantification of power decline with respect to time is known as module degradation rate.

As indicated previously, the measured I-V data of the various modules has been extrapolated to standard test conditions so as to enable us to compare their present-day performance with their initial performance at the time of installation (based on name plate ratings) leading us to the percentage degradation rates of the various electrical parameters like output power ( $P_{max}$ ), short-circuit current ( $I_{sc}$ ) and open circuit voltage ( $V_{oc}$ ). The series resistance and shunt resistance has also been calculated from the I-V curves, which help us understand the level of corrosion of the internal circuitry. We are going to present first the performance analysis of crystalline silicon PV modules followed by that of thin film technologies. We shall discuss the degradation of the electrical parameters ( $P_{max}$ ,  $I_{sc}$ ,  $V_{oc}$ ,  $FF$ ,  $V_{max}$ ,  $I_{max}$ ) with respect to climate and technology. Our findings are consistent with the results of Jordon *et al.* [8] and we shall present their findings side by side with our results in the following sections.

The first step taken in the analysis of the electrical data is to separate out the data that has high degree of error probability. Accordingly, the electrical data gathered under rainy conditions in Patna sites have not been considered in this analysis since the irradiance levels were very low ( $<150 \text{ W/m}^2$ ) which will introduce too much error in the STC extrapolation leading to overall wrong conclusions.

As explained in Section 5.3, we have considered a modified version of IEC 60891 translation procedure 1, called Procedure 1a, obtained by neglecting the series resistance and curve correction factor ( $R_s = 0$  and  $K = 0$ ). This procedure has been found to give an error within 13.5% for  $P_{max}$  for c-Si, and within 24% for thin film, provided irradiance is above  $550 \text{ W/m}^2$  (refer to Section 5.6).

## 7.2 Performance Degradation in crystalline Silicon Modules

Since the power output of the PV module is the main performance indicator, we shall discuss the power degradation rate first, and then try to relate the decrease in  $P_{max}$  to the changes in the various other parameters like  $V_{max}$ ,  $I_{max}$ ,  $V_{oc}$ ,  $I_{sc}$  and  $FF$ .

### 7.2.1 Degradation in power output

We have taken the current-voltage characteristics of each inspected module using a portable I-V curve tracer, and then corrected this curve to standard test conditions. From the corrected I-V curve, we have arrived at the present power generation capability (referred to as  $P_{max}$ ), and we have compared this present power capability to the rated power output given in the name plate of the module to arrive at the power degradation rate per year.

$$\% P_{max} \text{ Degradation Rate} = \frac{(P_{max,nameplate} - P_{max,present}) * 100}{P_{max,nameplate} * (\text{Age in Years})} \quad \%/year \quad \dots (7.1)$$

We are presenting the statistical distribution of the  $P_{max}$  degradation in the sub-section below, after which we shall discuss the variation noticed in  $P_{max}$  degradation across various technologies and in various climatic zones.

#### 7.2.1.1 Statistical distribution of power degradation rate

The degradation rates observed during the survey are shown in the histogram in Fig. 7.1 a, where the red curve is the extreme value distribution fit. A similar analysis has been done by Jordon *et al.* [8], who had compiled data from various sources, and this is shown in Fig. 7.1 b. The value of mean degradation is 1.51%/year and median value of degradation to be 1.24%/year. *It should be noted that in our survey we have inspected mainly visibly degraded modules, since the aim was to assess degradation mechanisms. Hence, the degradation rates reported in this survey are not typical degradation rates of a particular technology, but rather the degradation rates seen for modules showing visible degradation, and hence are higher than typical degradation rates.* This caveat should always be borne in mind while looking at the data in this and the next two chapters.

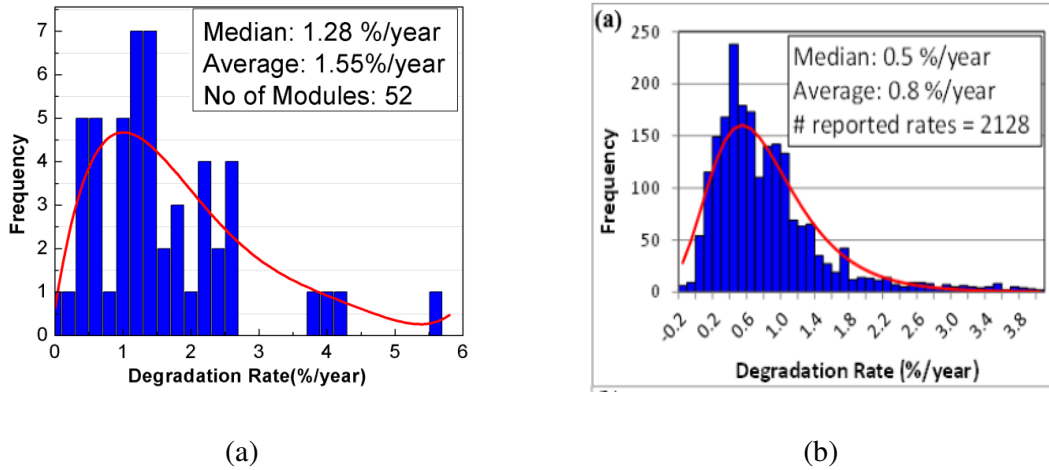

Fig 7.1 a: Histogram of degradation rate with extreme value fit.

Fig 7.1 b: Corresponding histogram quoted from the paper by Jordon *et al.* [8]

### 7.2.1.2 Influence of technology on power degradation rate

The Fig. 7.2 shows the  $P_{max}$  degradation per year for mono and multi crystalline silicon with the median as the crossbar. It is evident that the degradation rate for multi c-Si is slightly more than mono c-Si which is supported by the analysis done by Jordon *et al.* [8].

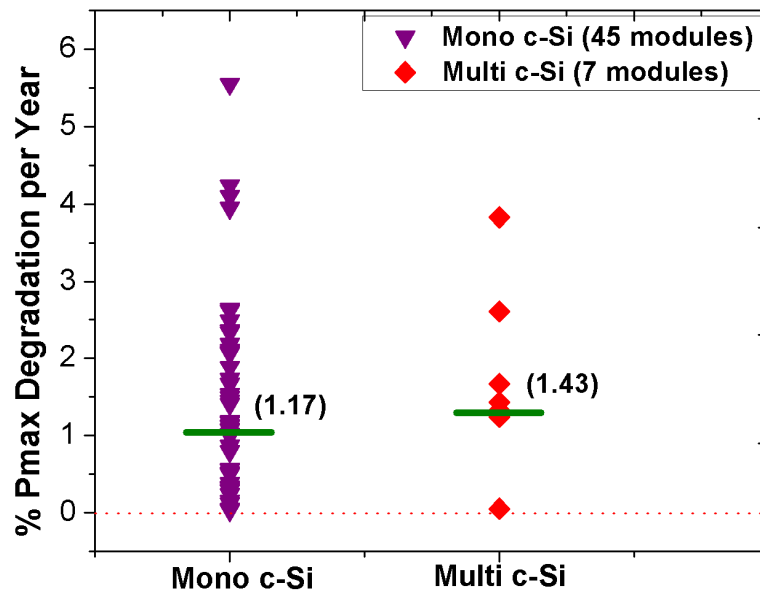

Fig 7.2:  $P_{max}$  degradation per year for mono and multi crystalline modules

### 7.2.1.3 Influence of climatic zone on power degradation rate

From the Fig. 7.3 it can be evident that the degradation in power is highest in Hot & Dry type of climate and least in Cold type of climate. The reason may be that discoloration which causes the heavy degradation in power is accelerated at higher temperature.

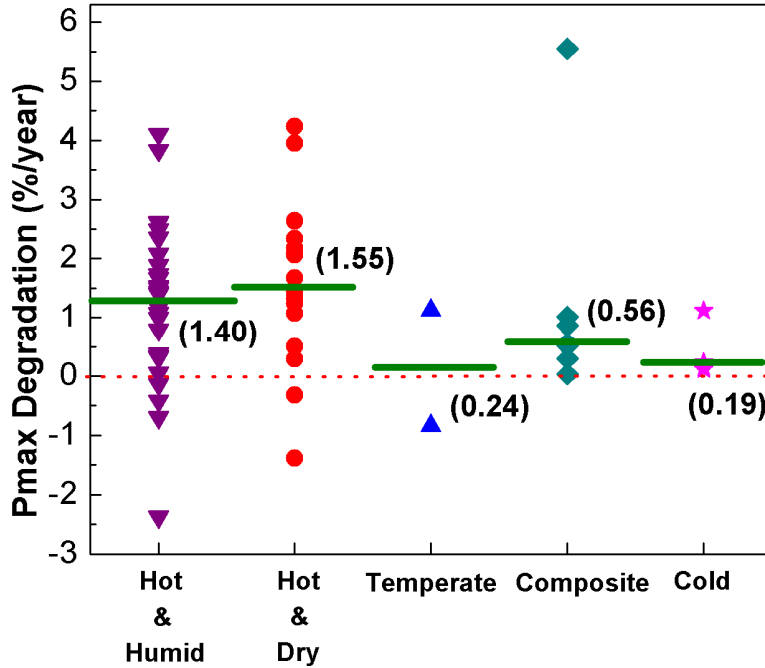

Fig 7.3: Comparison of  $P_{max}$  degradation rates in different climatic zone.

## 7.2.2 Degradation in maximum power point parameters ( $P_{max}$ , $I_{max}$ , $V_{max}$ )

We shall discuss the influence of technology and climate on the maximum power point parameters in the subsequent sub-sections.

### 7.2.2.1 Influence of technology

Figure 7.4 and 7.5 shows the annualized degradation rate for  $P_{max}$ ,  $I_{max}$  and  $V_{max}$  for mono and multi c-Silicon. The predominant decline appears to be in current and not in voltage. This is similar to the trend observed by Jordon *et al.* [8].

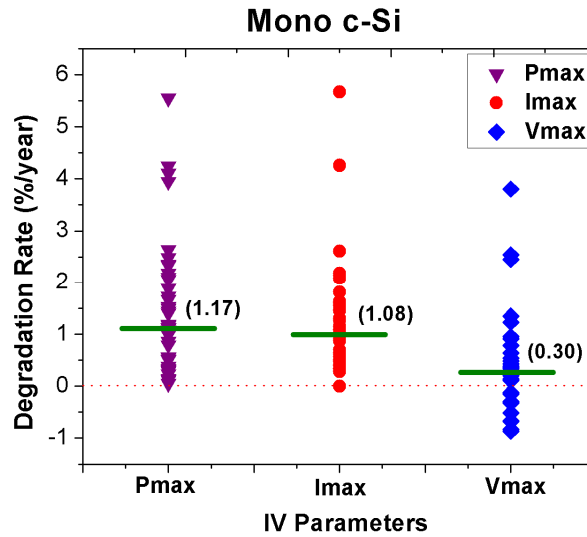

Fig 7.4: Annual degradation rate for  $P_{max}$ ,  $I_{max}$  and  $V_{max}$  for mono c-Si

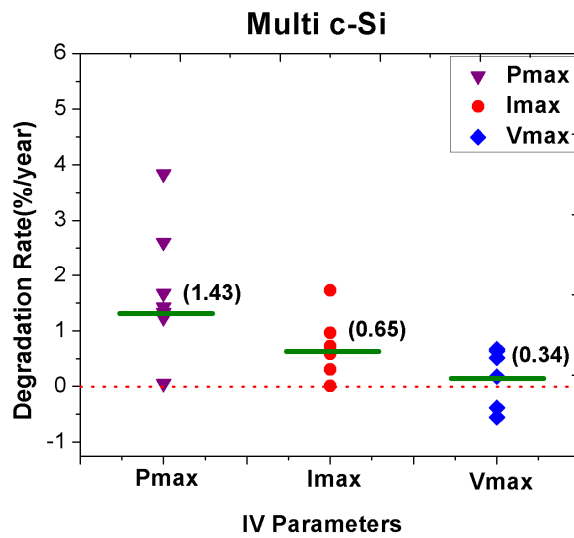

Fig 7.5: Annual degradation rate for  $P_{max}$ ,  $I_{max}$  and  $V_{max}$  for multi c-Si

### 7.2.2.2 Influence of climate

The maximum power point parameters distribution by the climatic zone for crystalline silicon modules is shown in fig. 7.6 (a)-(e). For most of the climatic zones,  $I_{max}$  degradation is the largest contributor to the  $P_{max}$  degradation. It can also be seen that for Cold and Dry type of climate,  $I_{max}$  degradation is more than the  $P_{max}$  degradation.

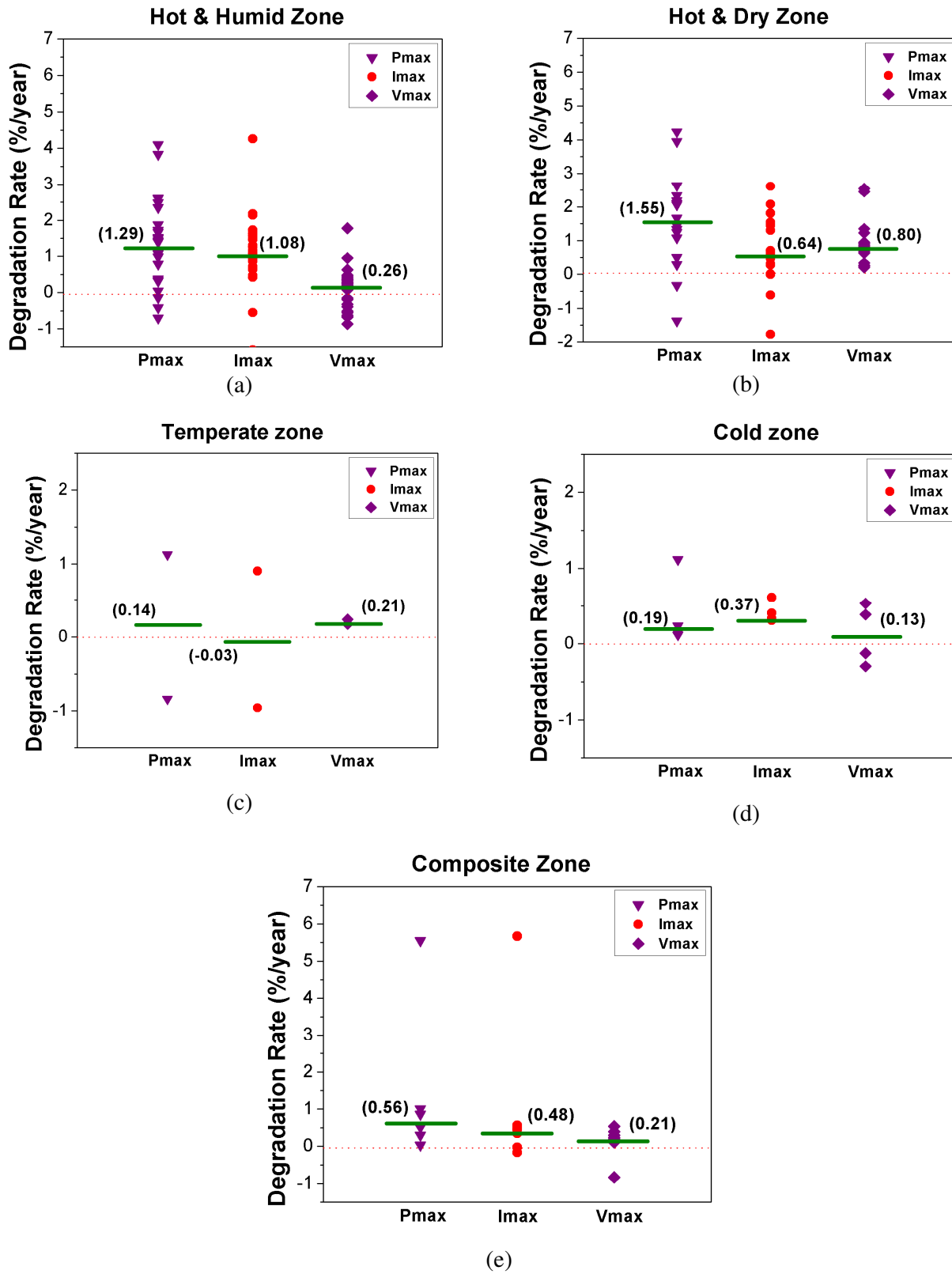
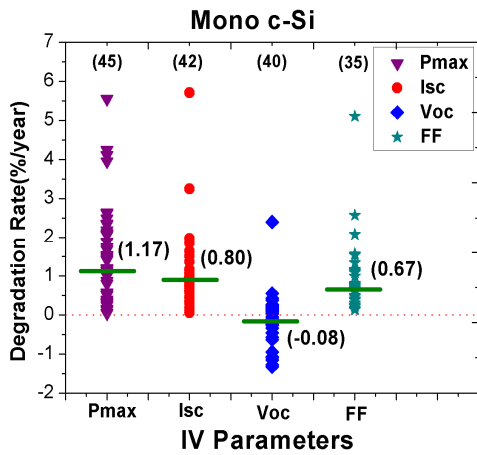

Fig 7.6: Maximum power point parameter degradation distribution for (a) Hot & Humid Climatic Zone (b) Hot & Dry Zone (c) Temperate Zone (d) Cold Zone (e) Composite Zone.

7.2.3 Degradation in I-V curve parameters ( $I_{sc}$ ,  $V_{oc}$  &  $FF$ )

7.2.3.1 Influence of technology

Of further interest is to understand how I-V parameter degradation differs by technology. Figures 7.7 and 7.8 show  $P_{max}$ ,  $I_{sc}$ ,  $V_{oc}$  and  $FF$  degradation for c-Si technologies: mono c-Si (Fig 7.7 a) and multi c-Si (Fig 7.8 a). Mono-Si and multi-Si display a similar pattern in which the highest  $P_{max}$  degradation is most closely correlated with degradation in  $I_{sc}$ , followed by  $FF$  and finally  $V_{oc}$ , which degrades little. Typical observed  $I_{sc}$  degradation can be attributed to delamination, discoloration and cracked individual cells while a smaller percentage can be attributed to light-induced degradation and soiling. Significantly less degradation comes from  $FF$ , typically associated with corrosion and solder-bond breakage. Similar results, shown in Fig 7.7 b and 7.8 b, are obtained by Jordon *et al.* [8].



(a)

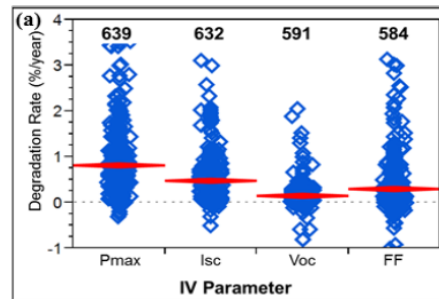

(b)

Fig 7.7 a:  $P_{max}$ ,  $I_{sc}$ ,  $V_{oc}$  and  $FF$  degradation for mono c-Si

Fig 7.7 b: Corresponding degradation rates quoted from the paper by Jordon *et al.* [8]

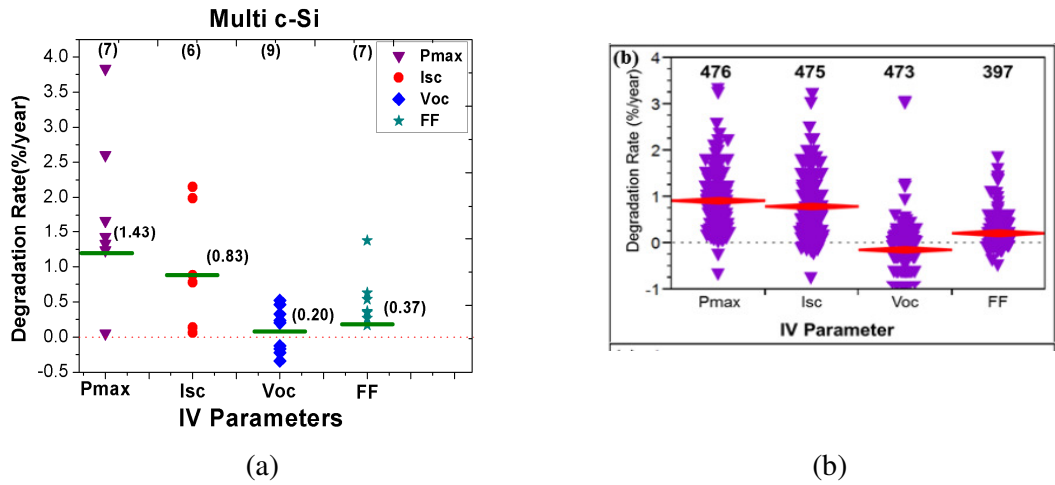

Fig 7.8 a:  $P_{max}$ ,  $I_{sc}$ ,  $V_{oc}$  and  $FF$  degradation for multi c-Si  
 Fig 7.8 b: Corresponding degradation rates quoted from the paper by Jordon *et al.* [8]

### 7.2.3.2 Influence of climate

The I-V parameter degradation distribution by climate zone for mono-c Si and multi-c Si is shown in Fig. 7.9 (a-e). For most climate zones  $I_{sc}$  degradation is the largest contributor to  $P_{max}$  degradation. It can be seen that for Cold type of climatic zone, the  $I_{sc}$  degradation is more than  $P_{max}$  degradation whereas  $V_{oc}$  actually improves.

Table 7.1 shown below gives the median values of  $P_{max}$  and I-V parameter percentage degradation per year in the five different climatic zones. In Temperate zone, we have data for only two modules and we are planning to undertake survey of some more sites in the temperate zone. It is clearly seen that the degradation rate for Hot & Dry type of climatic zone is the highest of all zones. This is likely due to the high temperatures of the desert-type climate leading to increased EVA browning which manifests itself in high  $I_{sc}$  degradation (see next chapter also).

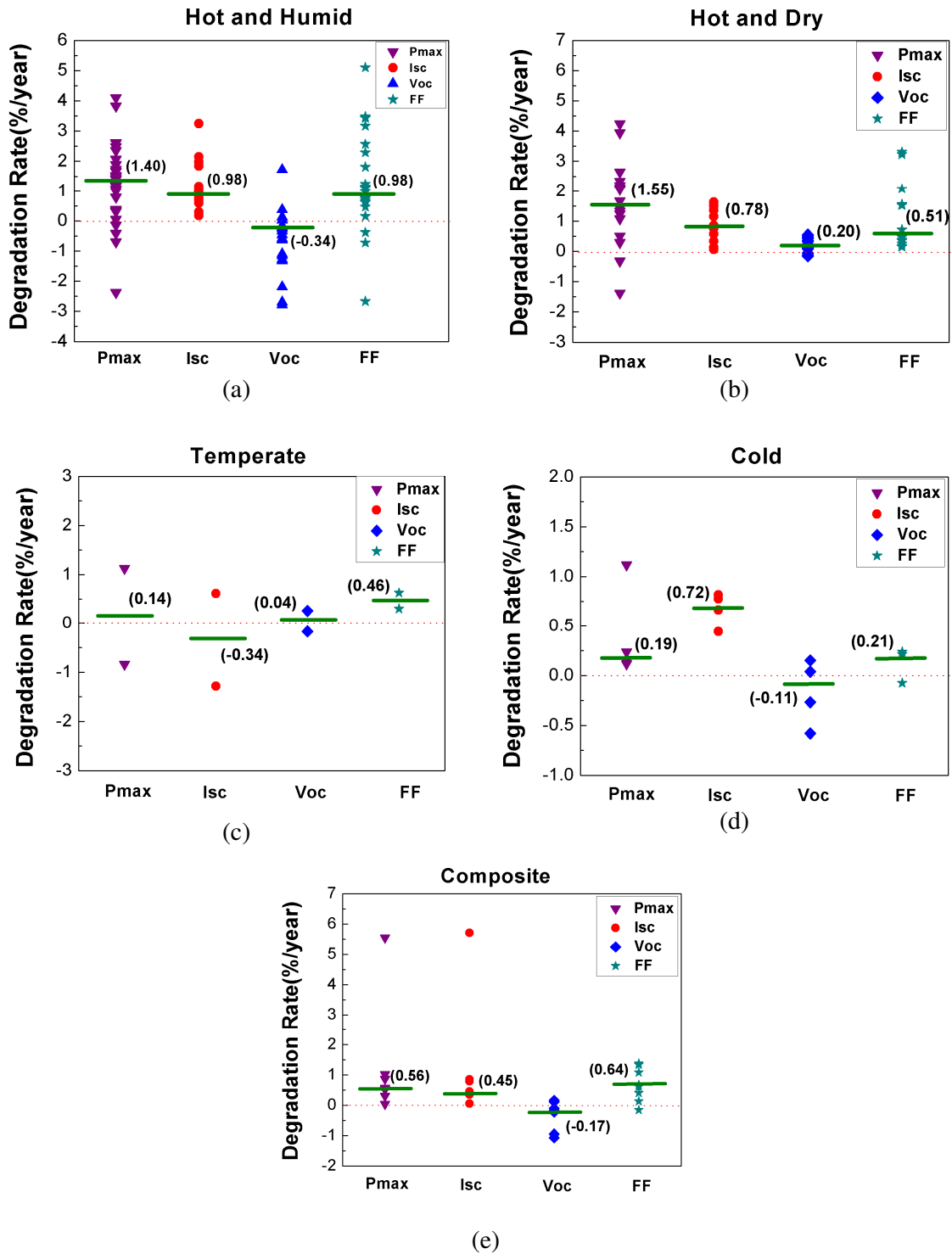

Fig 7.9: I-V parameter degradation distribution for (a) Hot & Humid climatic zone (b) Hot & Dry climatic zone (c) Temperate zone (d) Cold climatic zone and (e) Composite zone.

**Table 7.1: I-V Parameter Degradation by Climatic Zone***(Please note caveat in Sec. 7.2.1.1)*

Climatic Zone	Pmax(%/year)	Isc(%/year)	Voc(%/year)	FF(%/year)
Hot and Humid	1.29	0.98	-0.34	0.89
Temperate	0.24	-0.34	0.04	0.46
Composite	0.56	0.45	-0.17	0.64
Hot and Dry	1.55	0.78	0.20	0.51
Cold and Dry	0.19	0.72	-0.11	0.21

#### 7.2.4 Correlation between $P_{max}$ & I-V curve parameters' degradation

Analysis was conducted to determine the correlation of  $P_{max}$  degradation with the various I-V parameters (Figs 7.10-7.12). As degradation mechanisms are different in different climates, the analysis was split between “hot & humid” climate and the rest as “non hot& humid”. This split follows that of Jordan *et al.* [8]. A perfect correlation is indicated by the solid red line (which is a line of slope 1), and no correlation is indicated by the dashed red lines.

##### 7.2.4.1 Correlation between $P_{max}$ & $I_{sc}$

From Fig. 7.10(a) and Fig 7.10(c) it can be seen that most of the data points fall on the correlation line in both Hot & Humid and non Hot& Humid types of climate. Therefore it can be inferred that in any type of climate degradation in  $P_{max}$  is mainly because of degradation in  $I_{sc}$ . A similar result can be noted in Fig 7.10 (b) and 7.10 (d) taken from Jordon *et al.* [8].

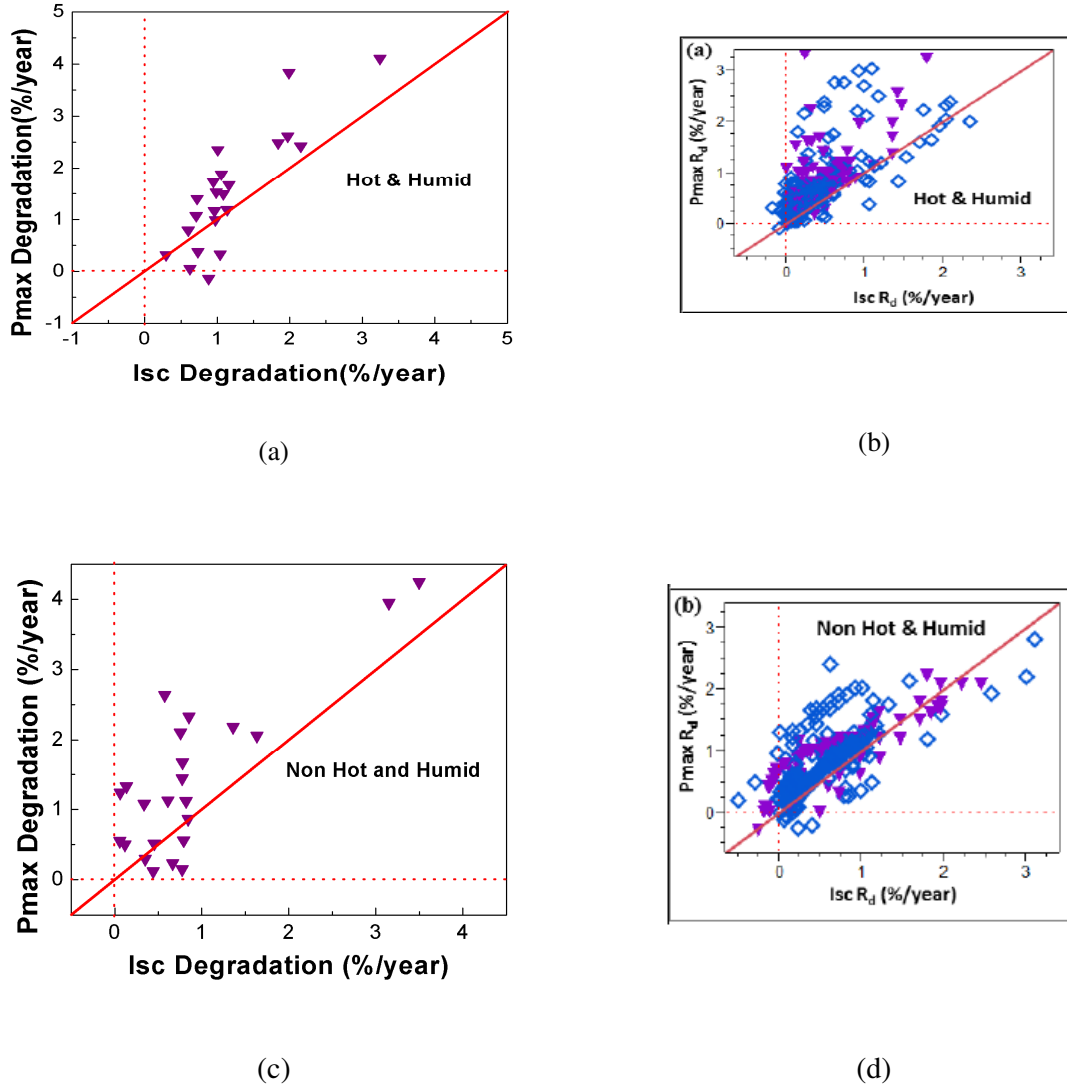

Fig 7.10: (a) Correlation of  $P_{max}$  with  $I_{sc}$  degradation for hot and humid climatic  
 (b) Corresponding correlation ( $P_{max}$  vs  $I_{sc}$  degradation) in paper by Jordan *et al.* [8]  
 (c) Correlation of  $P_{max}$  with  $I_{sc}$  degradation for non hot and humid climatic  
 (d) Corresponding correlation ( $P_{max}$  vs  $I_{sc}$  degradation) in paper by Jordan *et al.* [8]

#### 7.2.4.2 Correlation between $P_{max}$ & $V_{oc}$

Figure 7.11(a) show some data indicating substantial  $V_{oc}$  degradation in Hot and Humid climates. From Fig. 7.11(b) we can clearly see that in non Hot and Humid type of climate most of the  $V_{oc}$  data fall on the non-correlation line. It implies that degradation in  $P_{max}$  is not influenced by  $V_{oc}$  degradation. Similar result have also been reported in Jordon *et al.* [8]

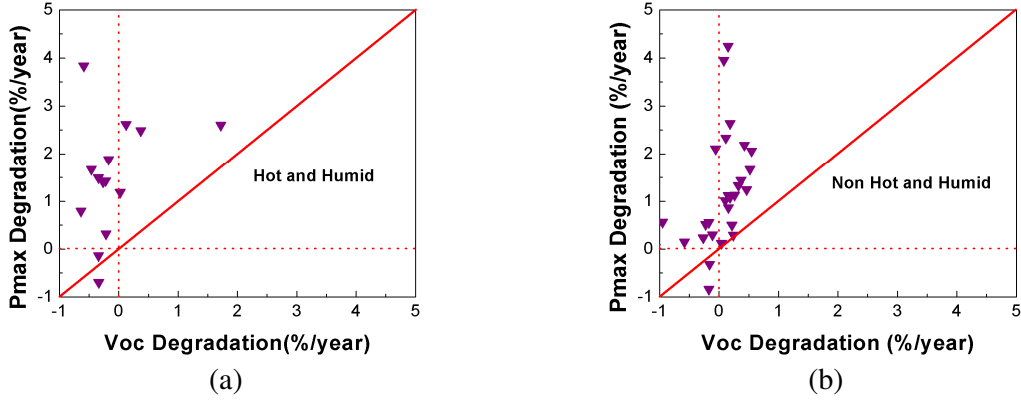

Fig 7.11: (a) Correlation of  $P_{max}$  with  $V_{oc}$  degradation for Hot and Humid climatic  
 (b) Correlation of  $P_{max}$  with  $V_{oc}$  degradation for non Hot and Humid climatic

### 7.2.4.3 Correlation between $P_{max}$ & $FF$

Figure 7.12(a) illustrates some modules with significant  $FF$  degradation in the Hot & Humid climate caused by increased series resistance. Most of the data points Fig. 7.12(b) are shifted away from the solid correlation line. It implies that degradation in  $FF$  is responsible for degradation in  $P_{max}$  in Hot & Humid zone but does not significant effect in non-Hot & Humid zone. Similar result have also been reported in Jordon *et al.* [8]

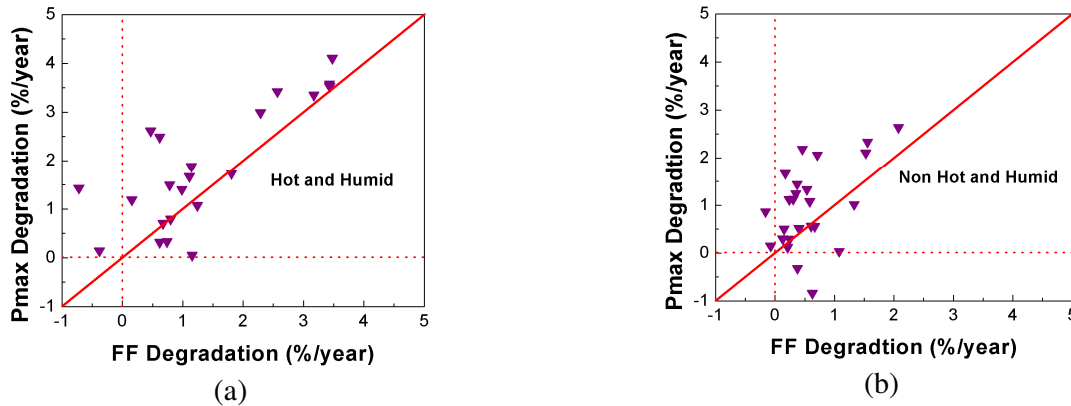

Fig 7.12: (a) Correlation of  $P_{max}$  with  $FF$  degradation for Hot & Humid climatic  
 (b) Correlation of  $P_{max}$  with  $FF$  degradation for non Hot & Humid climatic

### 7.2.5 Performance degradation of similar modules in different climatic conditions

During our survey, we were fortunate to encounter modules from the same manufacturer and of similar age, which were deployed in different climatic conditions. This allowed us to assess the effect of only climate, assuming that the modules themselves were very similar. Figure 7.13 shows the comparison in  $P_{max}$ , and Fig. 7.14 shows comparison of  $I_{sc}$ ,  $V_{oc}$  and  $FF$  for these modules.

7.2.5.1 Comparison in power output ( $P_{max}$ )

From Fig.7.13 we can infer that in hot climatic zones (Hot & Humid and Hot & Dry zones) we have the highest degradation in power as compared to other zones. It is well known that higher temperatures accelerate most of the degradation reactions and provide the activation energy necessary for such reactions. The modules in the cold climatic zone have the least degradation in the performance.

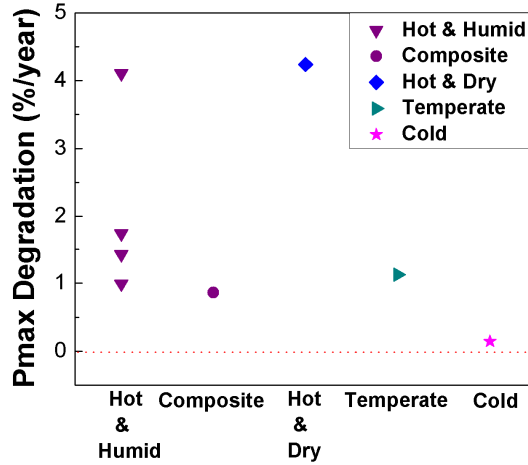

Fig 7.13: Comparison of  $P_{max}$  in different climatic conditions

7.2.5.2 Comparison in I-V curve parameters ( $I_{sc}$ ,  $V_{oc}$  &  $FF$ )

Figure 7.14 (a-c) shows the comparison of I-V parameters ( $I_{sc}$ ,  $V_{oc}$  &  $FF$ ) degradation in different climatic zones.

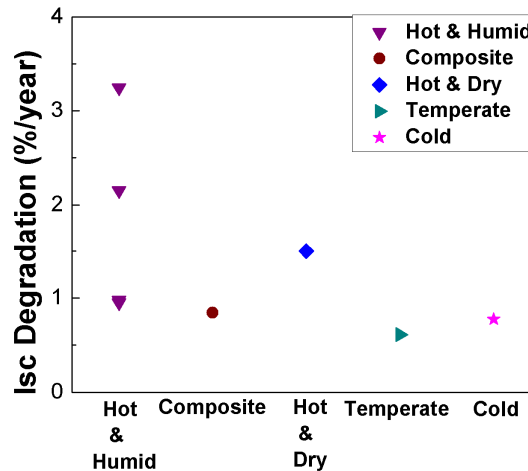

Fig: 7.14 (a): Comparison of  $I_{sc}$  in different climatic conditions

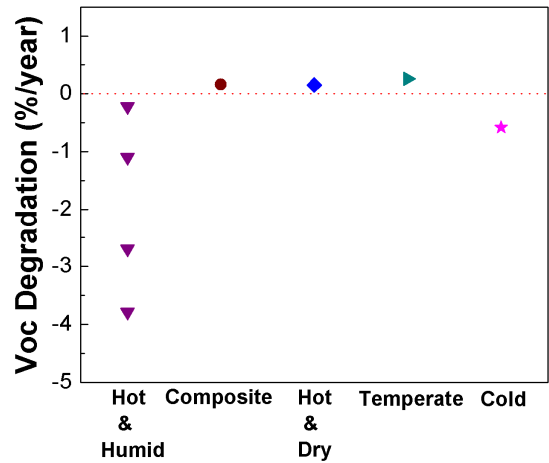

Fig: 7.14 (b): Comparison of  $V_{oc}$  in different climatic conditions

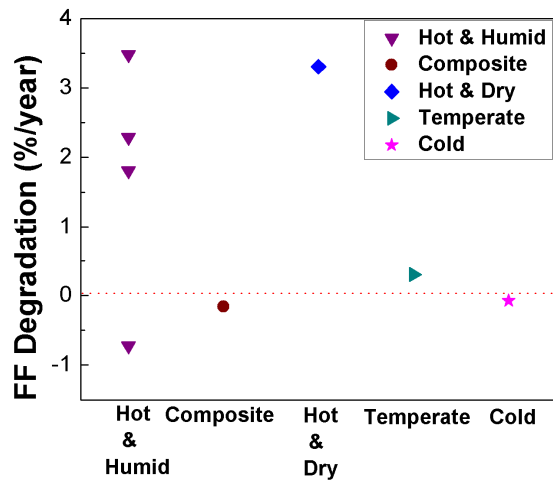

Fig: 7.14 (c): Comparison of  $FF$  in different climatic conditions

### 7.3 Performance Degradation in Thin film Modules

We have surveyed six numbers of thin film modules, out of which two are CIGS modules, while the other four are amorphous silicon multi-junction modules. Even though these numbers are small, and it is difficult to draw statistical conclusions, we present here the data for completeness. We will discuss the power degradation data of all the six modules, before presenting a comparison of the degradation rates of modules with and without “bar graph” corrosion. Then the degradation in the I-V parameters will be presented.

7.3.1 Degradation in power

Histogram of Fig 7.15 gives the degradation rate for different thin film technologies modules that were surveyed during the survey. Figure 7.15 indicates that the degradation in power is more in CIGS than amorphous silicon.

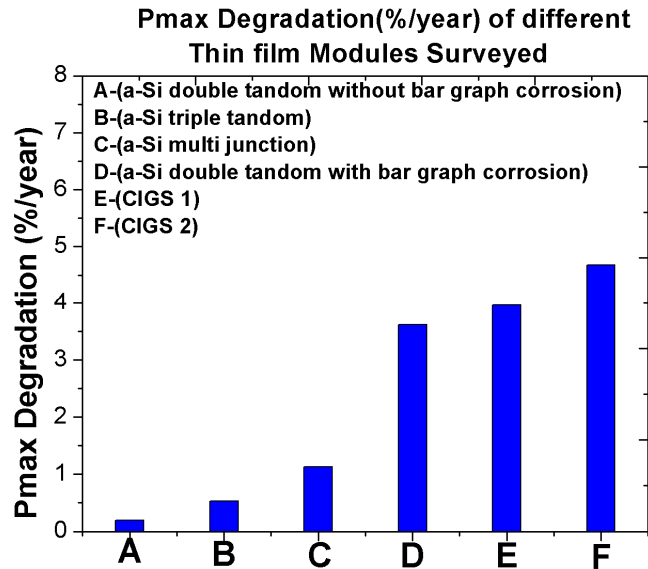

Fig 7.15:  $P_{max}$  degradation rate for different thin film technologies

Table 7.2 shows the calculated  $P_{max}$  value of two double tandem a-Si modules one having bar graph corrosion and other without any bar graph corrosion (bar graph corrosion is discussed in more detail in Chapter 8). It can be clearly noticed that the module which has bar graph corrosion has a high loss in power. However the module with no bar graph corrosion still meets their original power specification with very little loss in power. There is also a general conformity in the values as per the measurement done on these very same panels by John H. Wohlgemuth *et al.* [9] in 2011.

**Table 7.2:  $P_{max}$  value of a-Si with and without bar graph corrosion**

Module	Rated P <sub>max</sub> (Watts)	Measured P <sub>max</sub> (Watts) by John H. Wohlgemuth <i>et al.</i> [9] in 2011	Calculated P <sub>max</sub> (Watts) by Procedure 1a method (Data collected in 2013)
a-Si double Tandem (NO Bar graph corrosion)	43	42.6	42
a-Si double Tandem ( Bar graph corrosion)	43	33	25.88

The reason for high loss in power for the modules having the bar graph corrosion is mainly due the high degradation in fill factor. From Table 7.3 we can infer that there is a high degradation in the fill factor value for the modules having the bar graph corrosion. However the module with no bar graph corrosion meets specification with very less loss in the fill factor value.

**Table 7.3: Fill Factor value of a-Si with and without bar graph corrosion**

Module	Fill Factor (%) (Name plate data)	Calculated Fill Factor (%) by Procedure 1a method (Data collected in 2013)
a-Si double Tandem (NO Bar graph corrosion)	52.3	51.4
a-Si double Tandem ( Bar graph corrosion)	52.3	30.8

Table 7.4 shows the value of  $P_{max}$  degradation (%/year) for double tandem a-Si, triple tandem a-Si and CIGS modules. It can be inferred that there is a high degradation in  $P_{max}$  value for a-Si having the bar graph corrosion and its mainly due to the high loss in the fill factor value. Moreover the formation of a reverse junction and some degradation of all parameters around the edges are the likely cause of power loss for the CIGS modules [9]. These are both probably the result of moisture ingress around the sides. This is why most CIGS products now use glass-glass encapsulation with an edge seal. We can also notice a general conformity in the values of  $P_{max}$  degradation as per the analysis done by John H. Wohlgemuth *et al.* [9] in 2011.

**Table 7.4:  $P_{max}$  degradation (%/year) for several Thin Film Modules**

Module	Degradation in $P_{max}$ (%/year) Calculated by John H. Wohlgemuth <i>et al.</i> [9] in 2011	Degradation in $P_{max}$ (%/year) Calculated by Procedure 1a in 2013
a-Si double Tandem (NO Bar graph corrosion)	0.13	0.19
a-Si double Tandem ( Bar graph corrosion)	2.90	3.60
a-Si Triple Tandem	0.36	0.53
CIGS	4.00	3.96

### 7.3.2 Degradation in I-V Parameters

Figure 7.16 (a) shows  $P_{max}$ ,  $I_{sc}$ ,  $V_{oc}$  and  $FF$  degradation for different thin film technologies. Due to the small number of data points, amorphous silicon (a-Si) and copper indium gallium selenide (CIGS) modules have been overlaid on one plot. The IV parameter degradation pattern differs for thin-film technologies in comparison to crystalline silicon. All thin-film technologies show a significantly higher FF degradation (compared to crystalline silicon technologies), often associated with light-induced degradation of a-Si and an increase in series resistance in CIGS [9]. Similar results can be seen in Fig 7.16 b taken from Jordon *et al.* [8].

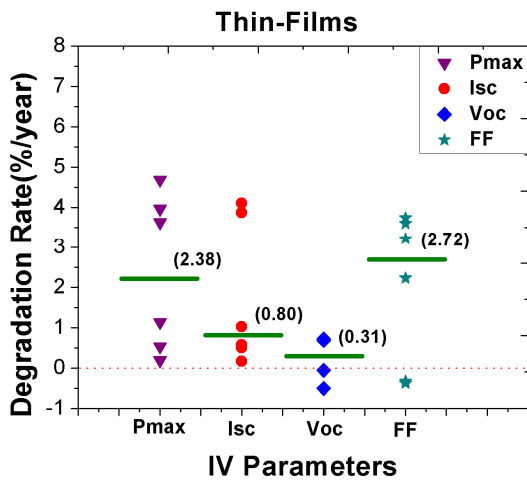

(a)

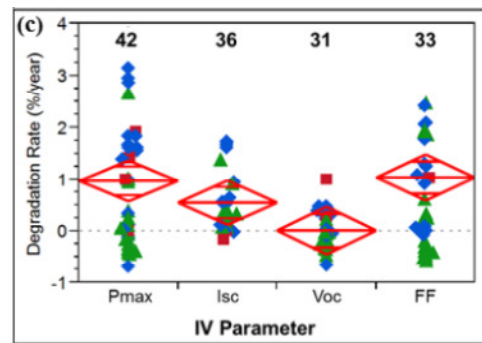

(b)

Fig 7.16 (a):  $P_{max}$ ,  $I_{sc}$ ,  $V_{oc}$  and  $FF$  degradation for thin film technology

(b): Corresponding degradation rates quoted from the paper by Jordon *et al.* [8]

## 7.4 Conclusions

From the survey data on old visibly-degraded modules in India presented above, it can be concluded that decrease in power output of the crystalline silicon modules is mainly due to degradation in the short-circuit current. This probably occurs because of the physical degradation of the encapsulant like discoloration and delamination, and is discussed in more detail in the next chapter. We have also found that the rate of degradation of modules is greater in the Hot zones as compared to the other climatic zones (Composite, Temperate and Cold), being highest in the Hot & Dry zone. This is again likely to be due to accelerated encapsulant degradation at higher temperatures. Modules placed in the Cold climatic zone of Ladakh have suffered the least degradation in power. For thin film modules, unlike the c-Si modules, fill factor plays the major role in power degradation. Paucity of data prevented us from doing a climatic zone analysis for thin film modules. In the following chapter, we

shall discuss the visual degradation observed on modules of different technologies in the various climatic zones, and present the correlation between the electrical degradation presented in this chapter, with the visual degradation of the modules.

## 8. Analysis of Visual Degradation

---

### 8.1 Introduction

The visual appearance of equipment often gives the first clues about the physical state and health of the equipment. Though electrical faults cannot always be located by visual inspection, some aspects of PV module performance degradation are well reflected in the visual appearance of the panel. During our All-India PV Survey, we have collected visual degradation data of modules by filling up a visual degradation checklist in addition to taking photographs of the modules, and also infrared images in some cases. A majority of the modules surveyed fall in the crystalline silicon category (both mono- and multi-) while only a few belong to the thin film category. Hence visual degradation observed in crystalline silicon modules is presented first and the other category is briefly touched upon at the end of this chapter. Most of the degradation mechanisms are gradually occurring processes, so the older the module, the more prominent will be the degradation. Hence, for analyzing the degradation data, the modules have been segregated into various age bins: 1-5 years old i.e. very new; 6-10 years old i.e. moderately new; 11-20 years old i.e. moderately aged; and 21-30 years old i.e. significantly aged and highly weathered.

In order to understand the forthcoming analysis, it would be useful to have some basic understanding of the structure of a PV module. Crystalline silicon modules usually have a framed body comprising of a glass cover at the top, followed by an encapsulant layer, then the solar cell beneath it, after which there is again encapsulant layer and finally there is a backsheet at the bottom. The encapsulant and the backsheet are usually polymeric compounds. The encapsulant provides a cushion for the fragile solar cells to rest on and also acts as a protective insulating cover around the solar cells.

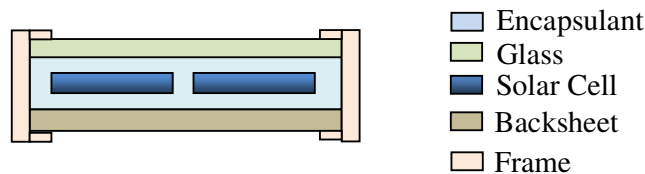

Fig. 8.1: Structure of a typical crystalline silicon PV module

## 8.2 Visual Degradation Modes Observed in Crystalline Silicon Modules

The major types of visual degradation in crystalline silicon modules reported by M.A. Quintana *et al.* [18] are listed below:

- a) Front Glass – Breakage, haziness
- b) Encapsulant – Discoloration, Delamination
- c) Metallization – Discoloration due to Corrosion
- d) Back-sheet – Delamination, Bubbles, Cracks/scratches, Burn marks
- e) Frame – Corrosion, Bends, Disjoint edges
- f) Junction Box – Weathering, Dents, Missing cover, Leakage

Out of the various types of visual degradation we have noticed during our survey, the statistics presented below in Table 8.1 show that encapsulant discoloration is the most commonly observed mode of visual degradation of the modules. Ethyl Vinyl Acetate (EVA) is the most commonly used encapsulant in PV modules and the available literature indicates that browning of the initially transparent EVA can lead to significant reduction in the intensity of light reaching the solar cell, which in turn reduces the short circuit current of the module and also the power output. Degradation of the EVA, upon exposure to UV rays and high temperatures, not only causes the discoloration, but also produces aldehydes and acetic acid which can corrode the metallization on solar cells and the interconnect ribbons. Such corrosion would appear as discoloration on the metallization and has been seen in 67% of the modules inspected. The backsheet of many modules has suffered degradation like delamination, bubbles and chalking (powder formation).

**Table 8.1: Percentage of modules affected with different visual degradations**

Visual degradation observed	Percentage of modules affected (%) [Total 57 nos. crystalline silicon modules]
Discoloration of encapsulant	79
Corrosion of metallization, interconnects & output terminals	67
Frontside delamination	26
Bubbles & delamination in backsheet	12
Chalking of backsheet	19
Junction Box damage	22
Frame damage/corrosion	39

### 8.2.1 Discoloration of encapsulant

The encapsulant in a PV module provides structural support & protection to the fragile solar cells, while also providing electrical isolation and good optical coupling with the glass. Since the incident photons must reach the solar cells unhindered, the encapsulant should be transparent. The most widely used encapsulant today is Ethyl-Vinyl Acetate (EVA), but different manufacturers use different formulations by adding various additives to stabilize the EVA and protect it from degradation. In spite of their efforts, EVA has been found to discolor in the long run, initially turning yellow (light discoloration) and progressively moving to darker shades of brown [27] (dark discoloration), as is evident in Fig. 8.1 below. This browning is due to generation of long-chain polyenes in the EVA upon exposure to UV rays and high temperatures [27].

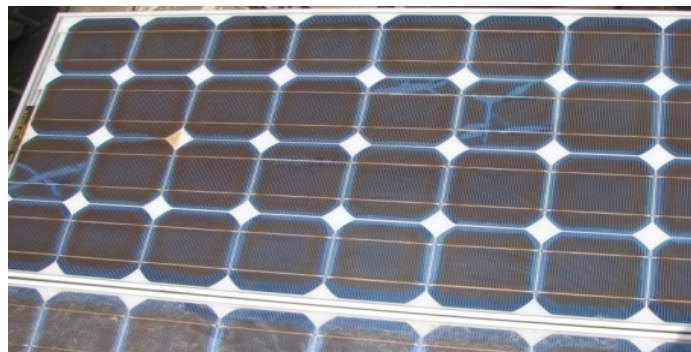

Fig. 8.2: Module having dark discoloration on solar cells

The table and graphs below show the distribution of discoloration in modules in different age groups in the various climatic zones. Table 8.2 indicates the percentage of modules affected and also the

ALL INDIA SURVEY OF PV MODULE DEGRADATION: 2013

sample size in the respective climatic zone (given in brackets). The sample size must be looked into before arriving at any conclusion from these data, because in some of the age groups we could survey very few modules, and the associated percentage may be misleading if seen in isolation. For example, only 1 module was surveyed in the Temperate zone in the 11-20 years age group and it had encapsulant discoloration, so the percentage of modules discolored comes to 100% but this does not mean that all modules installed in the Temperate zone will get discolored. Figure 8.2 presents the actual data of modules with no discoloration, light discoloration or dark discoloration, while Fig. 8.3 shows the percentage of modules affected by discoloration in the various climatic zones and age groups. These graphs do not show bars for certain zones, if that data is not available in the survey (like no module was surveyed in Cold zone in 1-5 years' age group).

**Table 8.2: Percentage of modules effected by discoloration of encapsulant in various climatic zones (nos. in bracket indicate the sample size in respective zone)**

<b>Climatic Zone</b>	<b>1 – 5 yrs old</b>	<b>6 - 10 yrs old</b>	<b>11 - 20 yrs old</b>	<b>21-30 yrs old</b>
<b>Hot &amp; Humid</b>	50% (4)	67% (3)	90% (21)	50% (2)
<b>Hot &amp; Dry</b>	-- (0)	100% (1)	100% (6)	100% (3)
<b>Composite</b>	20% (5)	-- (0)	100% (6)	100% (1)
<b>Temperate</b>	-- (0)	0% (1)	100% (1)	-- (0)
<b>Cold</b>	-- (0)	-- (0)	67% (3)	-- (0)

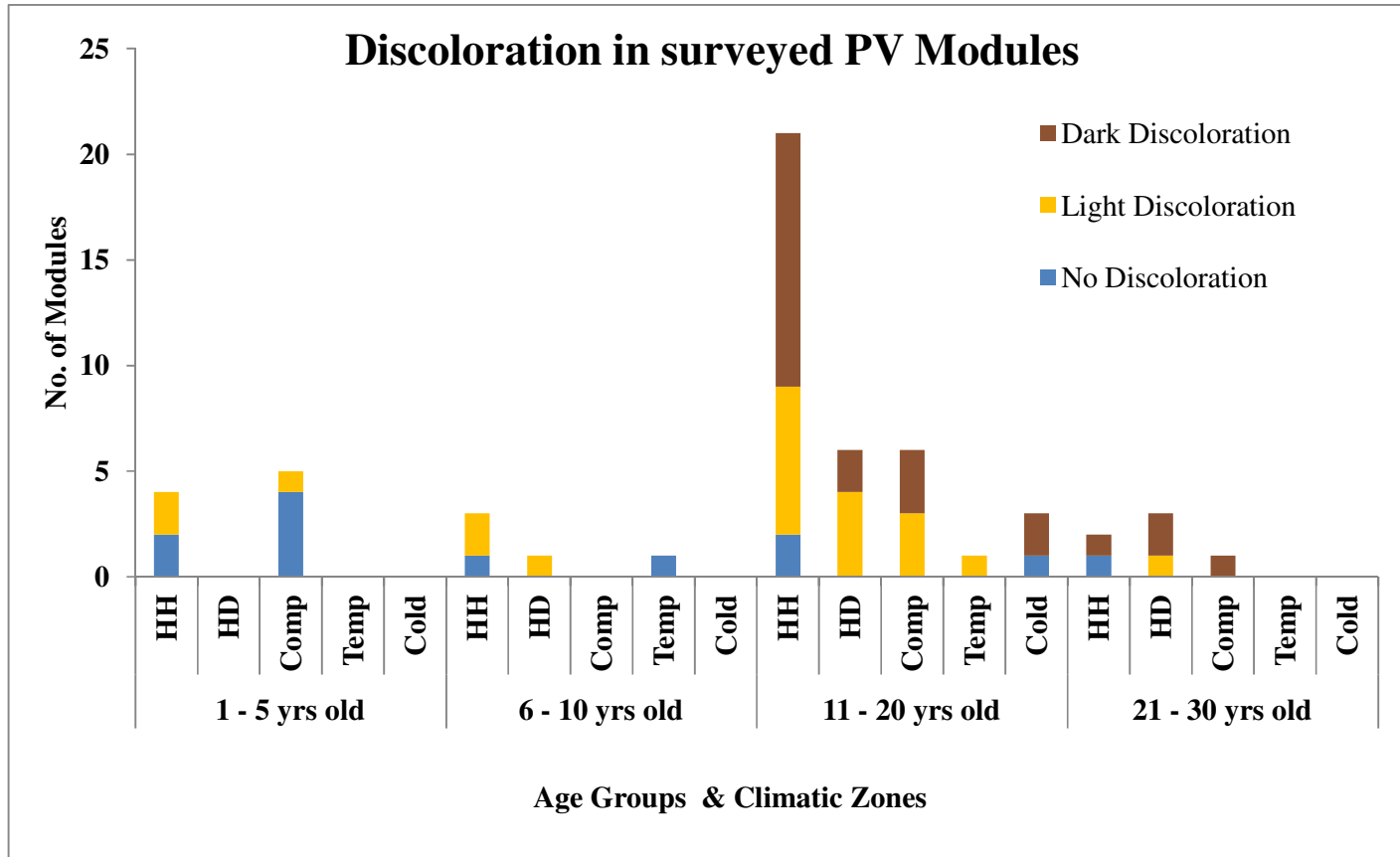

Fig. 8.3: Discoloration in modules in the respective climatic zones and age groups.  
 HH: Hot & Humid zone, HD: Hot & Dry zone, Comp: Composite zone, Temp: Temperate zone, Cold: Cold zone

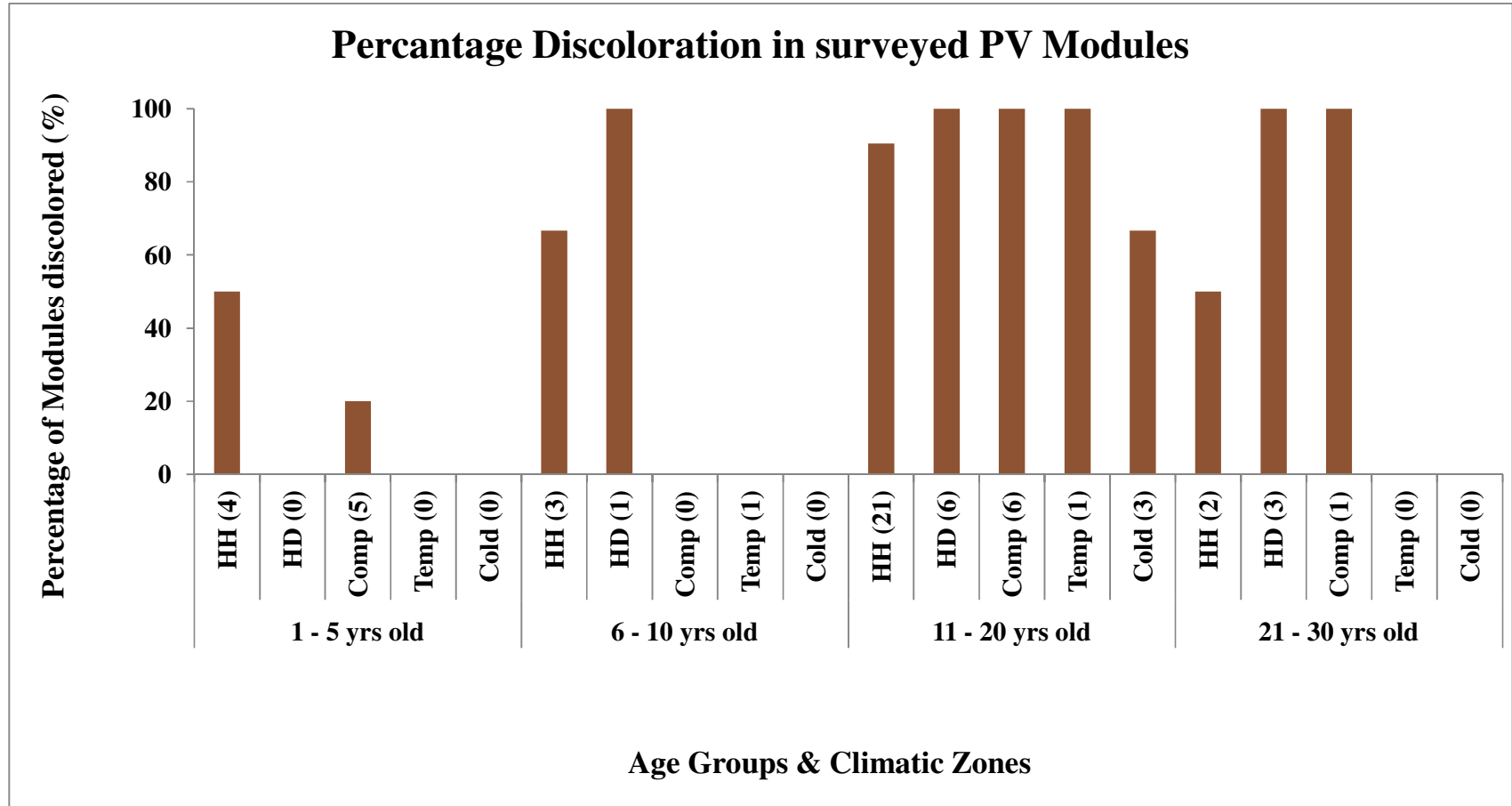

Fig. 8.4. Percentage of surveyed modules that had encapsulant discoloration (light or dark) in the respective climatic zone & age group. The figures in bracket indicate the total sample size in that climatic zone for that age-group (“0” indicates no module sample).  
 HH: Hot & Humid zone, HD: Hot & Dry zone, Comp: Composite zone, Temp: Temperate zone, Cold: Cold zone

From above graphs, it can be seen that discoloration has been observed in all climatic zones of India and in all age bins (wherever samples are available). The highest percentage of discolored modules has been found in the Hot & Dry zone, followed by the Hot & Humid zone. In the Cold zone site (Hanle Astronomical Observatory in Ladakh) we have seen that crystalline silicon modules of one particular manufacturer had all shown dark discoloration while those of another manufacturer installed side-by-side had no discoloration, though both systems were installed 15 years ago (see Fig. 8.4). This hints that the composition of the encapsulant and/or the processing has a significant bearing on the discoloration. Also we have found a 28 year old crystalline silicon module with glass-glass packaging (installed in Hot & Humid climatic zone) which has shown no discoloration (refer Fig. 8.5). We suspect that the encapsulant used might not be EVA (the concerned manufacturer has been contacted for details about the encapsulant, and their response is awaited). EVA has a particular shelf-life in storage within which period it must be used in the module. Some manufacturers stock huge amounts of EVA and hence may sometimes use expired EVA in their modules if their module production rate is slowed down due to market conditions. This inevitably gives rise to discoloration of the EVA in the long run. A mechanism should be put in place so that such practices can be checked as far as possible. Detailed study by A.W.Czanderna and F.J.Pern [27] has indicated that using the proper ratio of additives (ratio of UV absorber to UV stabilizer) can retard the UV induced degradation of the EVA and slow down the discoloration process. However, not all PV manufacturers may be aware of these guidelines. Another way to reduce the rate of discoloration is to use cerium oxide containing glass (which will act as a UV screen), but this is not always used by all manufacturers.

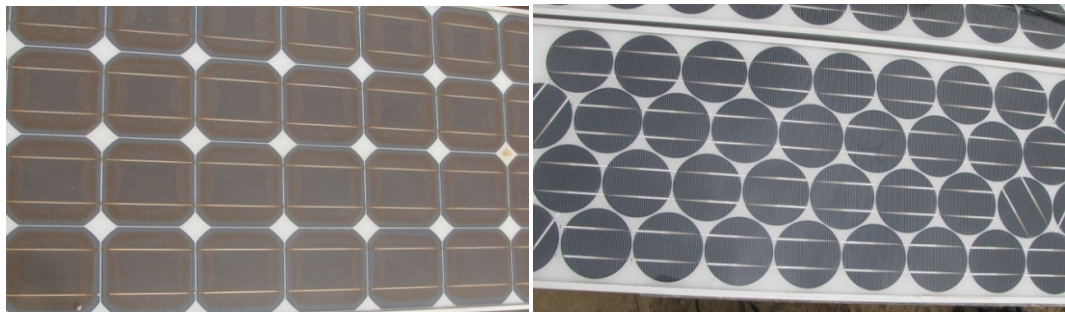

Fig. 8.5: Modules of different manufacturers installed at Hanle 15 years ago

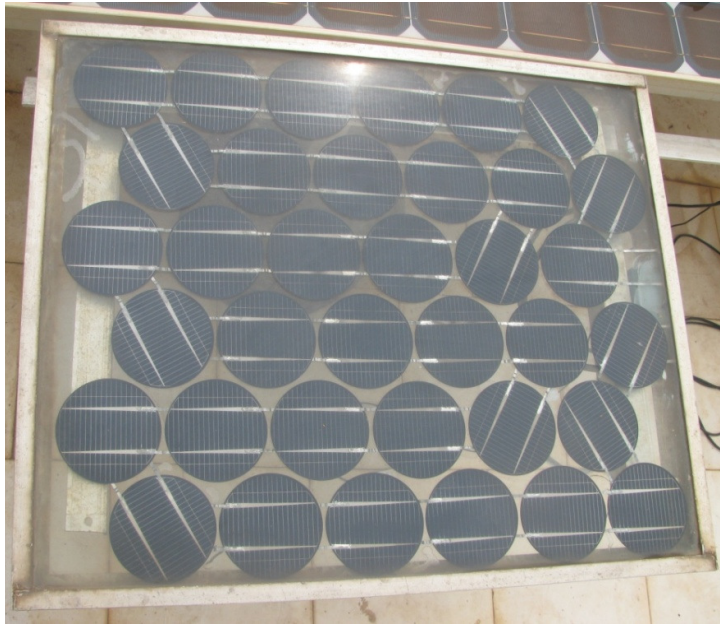

Fig. 8.6: 28 year old PV module (glass on both top & bottom) showing no discoloration of the encapsulant

A general observation in a majority of the discoloured modules is that the shape of discolored zone closely follows the shape of the solar cell but is proportionately smaller in size, leading to a ring of blue (actual color of solar cell) along the outer periphery of the brown zone, in each discolored cell as seen in Fig. 8.7. A literature survey indicates that the browning of the EVA is reversed by oxygen in presence of UV radiation, in a process called Photo-oxidative bleaching [27]. Since most backsheets are permeable to atmospheric gases, the oxygen enters into the module from the back side and makes its way into the top of the solar cell through the edges. This entry of oxygen starts a competition in the EVA (on top of the solar cells) between the browning process and the bleaching process, and the blue ring is the zone where the oxygen is able to diffuse fast enough to bleach out the browning EVA [27]. Also in some of the surveyed modules, there is an uneven discoloration in the solar cells (refer Fig. 8.8), wherein small patches in the cells at irregular positions remain blue, while the rest of the portions turn brown. Upon further investigation it has been found that in such cases, there is often a puncture or scratch in the back-sheet just below the blue portion. This puncture would enable rapid oxygen ingress into the module which would then move to the top of the solar cell (through cracks in the solar cells which would have been introduced when the puncture occurred) and bleach the brown EVA back to transparent colour (by photo-oxidative bleaching). Figure 8.9 shows a very interesting pattern developing on a solar cell of a module installed in 1995. The blue zig-zag lines are created due to the cracks in the solar cell, which allowed oxygen transport to the top EVA layer and consequent bleaching along these cracks. Hence such blue zig-zag patterns in the brown background acts as a means to detect the presence of cracks in the solar cells. Also we

have found a module having a shattered glass cover, which shows no discoloration at all (since oxygen got ready access to the encapsulant through the fractured glass and performed the bleaching task), whereas other modules at the same site with front glass intact have discolored significantly. The power output of the shattered-glass module was interestingly found to be higher than that of the neighboring modules (which had significant discoloration). However, it is obviously not advisable to use PV modules having a shattered glass-cover as there can be shock hazard from such a module, apart from the accelerated degradation of module performance due to corrosion initiated by moisture ingress into the module.



Fig. 8.7: Browning of EVA from the centre with transparent EVA intact at the edge of the solar cell



Fig. 8.8: Uneven discoloration (left) in a module and puncture in the back-sheet (right) of same module.

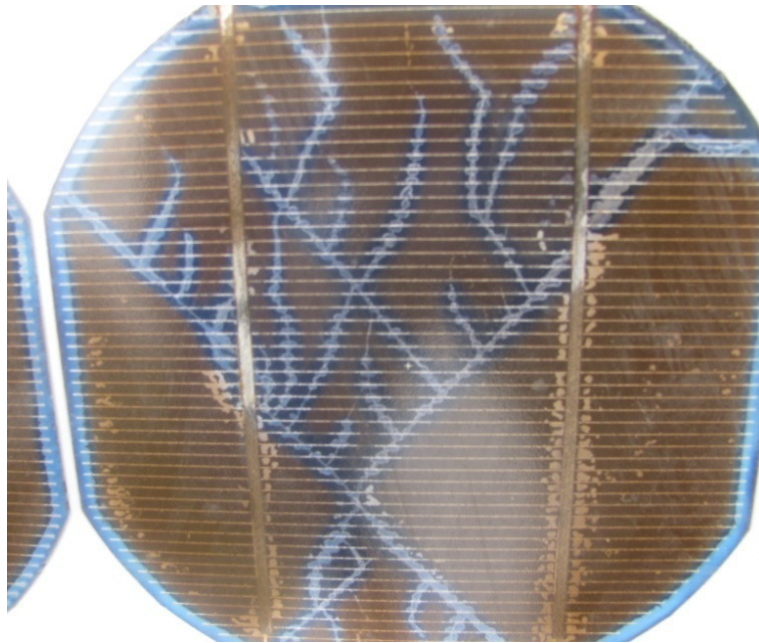

Fig. 8.9: Cracks in a solar cell are made visible by the photo-oxidative bleaching effect on the otherwise discolored EVA.

### 8.2.2 Front-side delamination of encapsulant

The delamination of encapsulant on the top surface of the solar cells shows up as white patches on the cells, in contrast to the blue colour of the anti-reflective coating of the solar cells. The delaminated area reflects much of the incident light and reduces the light input to the affected cell. Also the thermal conductivity is reduced in the affected zone, so the local temperature can be higher than adjoining delamination-free areas. This can be verified from the images shown below (Fig. 8.10), wherein we can see that the bottom right corner of the module has delamination and busbar corrosion and this cell runs hotter as per the infra-red image (bottom image of Fig. 8.10). This is referred to as Hot Spot and has detrimental effects on the module performance. The void created in the delaminated region can serve as an accumulation site for moisture and oxygen and this can accelerate the corrosion of the fingers and busbar at the delamination site. Figure 8.11 shows delamination in a solar cell along cracks close to the centre of the cell, which is evident from the blue colour along the delaminated zone. Delamination can take different shapes, like the tiny bubbles seen spread over a solar cell in Figure 8.12.

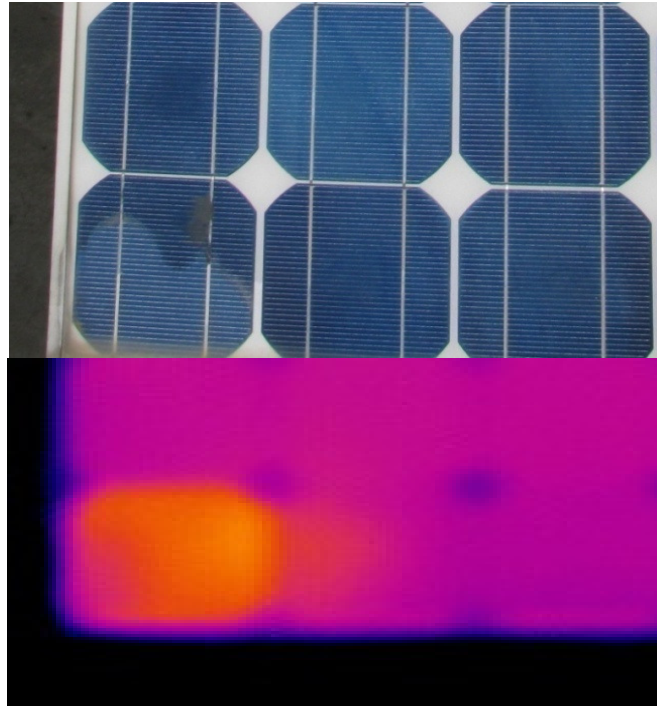

Fig. 8.10: Delamination (seen as light blue region in the bottom left-most solar cell) of a module (top image) installed in Composite zone in 1999 and its infra-red image (bottom image)

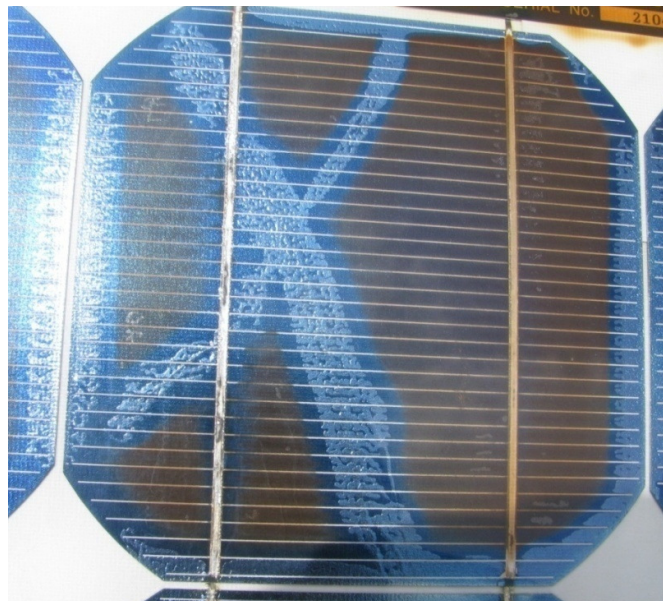

Fig. 8.11: Delamination (light blue region seen along the edges of the solar cell and crisscrossing the centre of the solar cell) in a PV module installed in Hot & Dry climate in 2000.

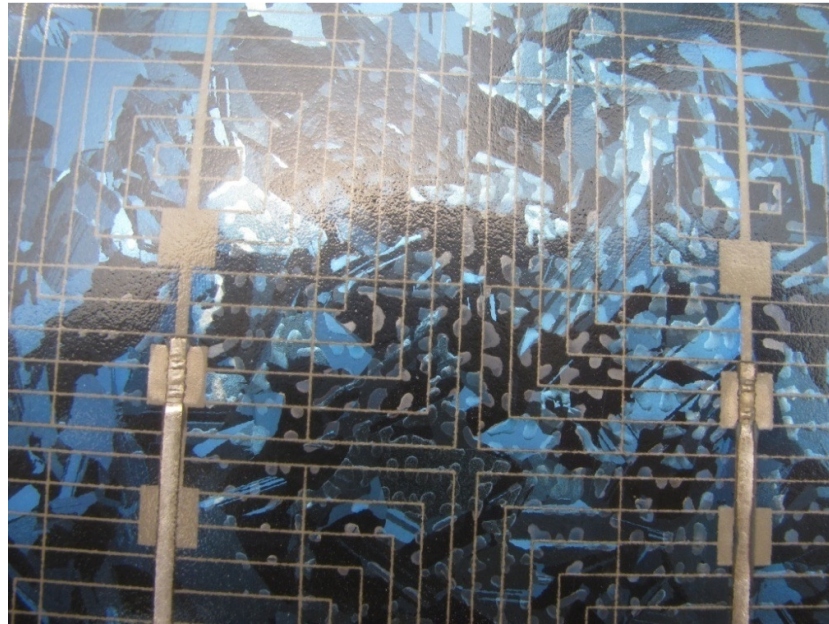

Fig. 8.12: Delamination (bubbles) in a PV module installed in Hot & Dry climate in 1988.

In the survey, delamination has not been observed in the younger modules (age below 10 years) in any of the climatic zones, as indicated in the Table 8.3. About one-third of the inspected modules in 11-20 years age bin showed delamination irrespective of climatic zone while all modules older than 20 years in Hot & Dry zone were affected. The data for temperate zone is too small to draw any conclusion. This data has been graphically shown in Figs. 8.13 and 8.14.

**Table 8.3: Percentage of modules effected by front-side delamination in various climatic zones (nos. in bracket indicate the sample size in respective zone)**

Climatic Zone	1 – 5 yrs old	6 - 10 yrs old	11 - 20 yrs old	21-30 yrs old
Hot & Humid	0% (4)	0% (3)	29% (21)	50% (2)
Hot & Dry	-- (0)	0% (1)	33% (6)	100% (3)
Composite	0% (5)	-- (0)	33% (6)	0% (1)
Temperate	-- (0)	0% (1)	0% (1)	-- (0)
Cold	-- (0)	-- (0)	33% (3)	-- (0)

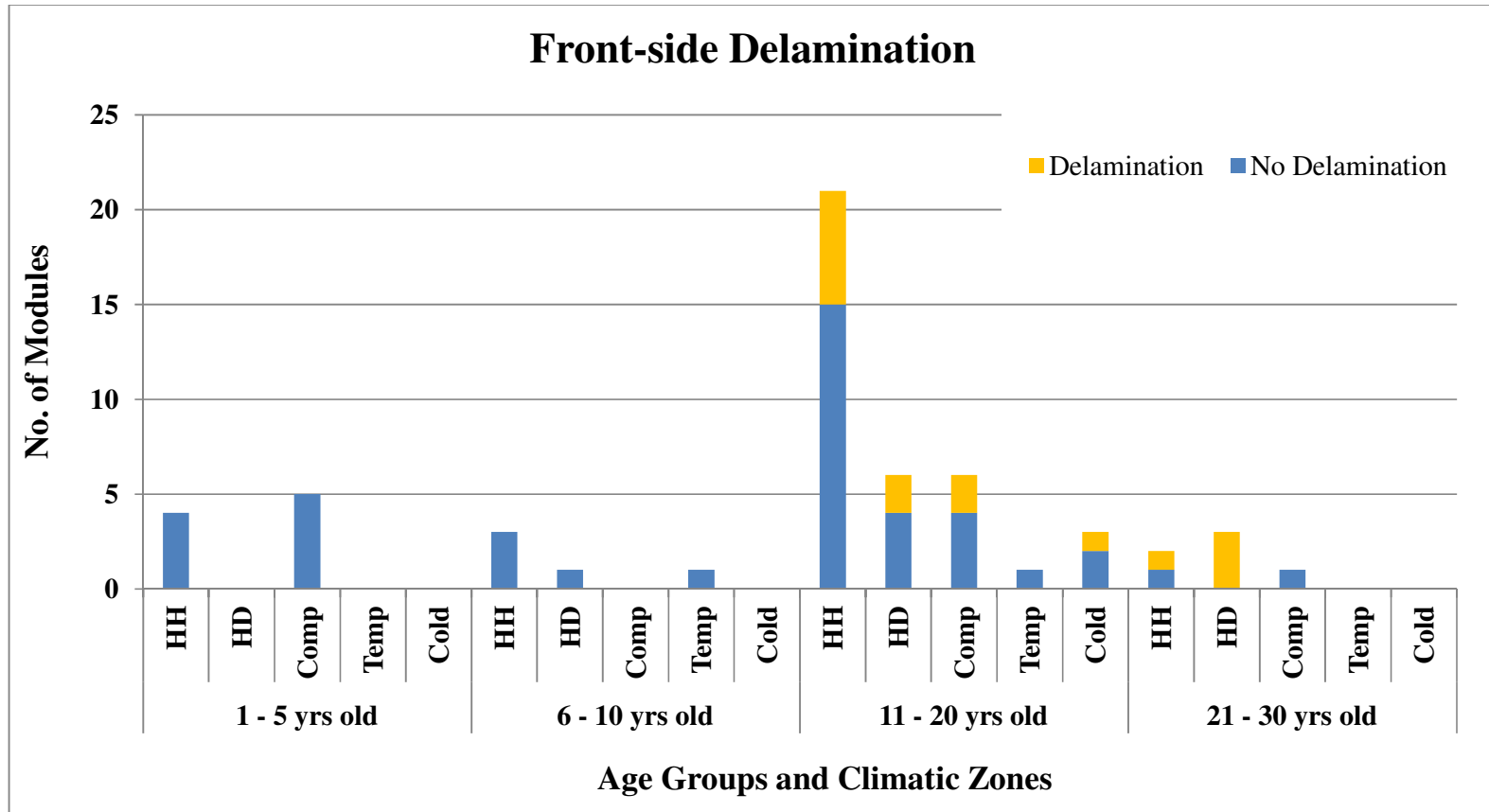

Fig. 8.13: Front-side delamination in modules in the respective climatic zones and Age groups.  
 HH: Hot & Humid zone, HD: Hot & Dry zone, Comp: Composite zone, Temp: Temperate zone, Cold: Cold zone

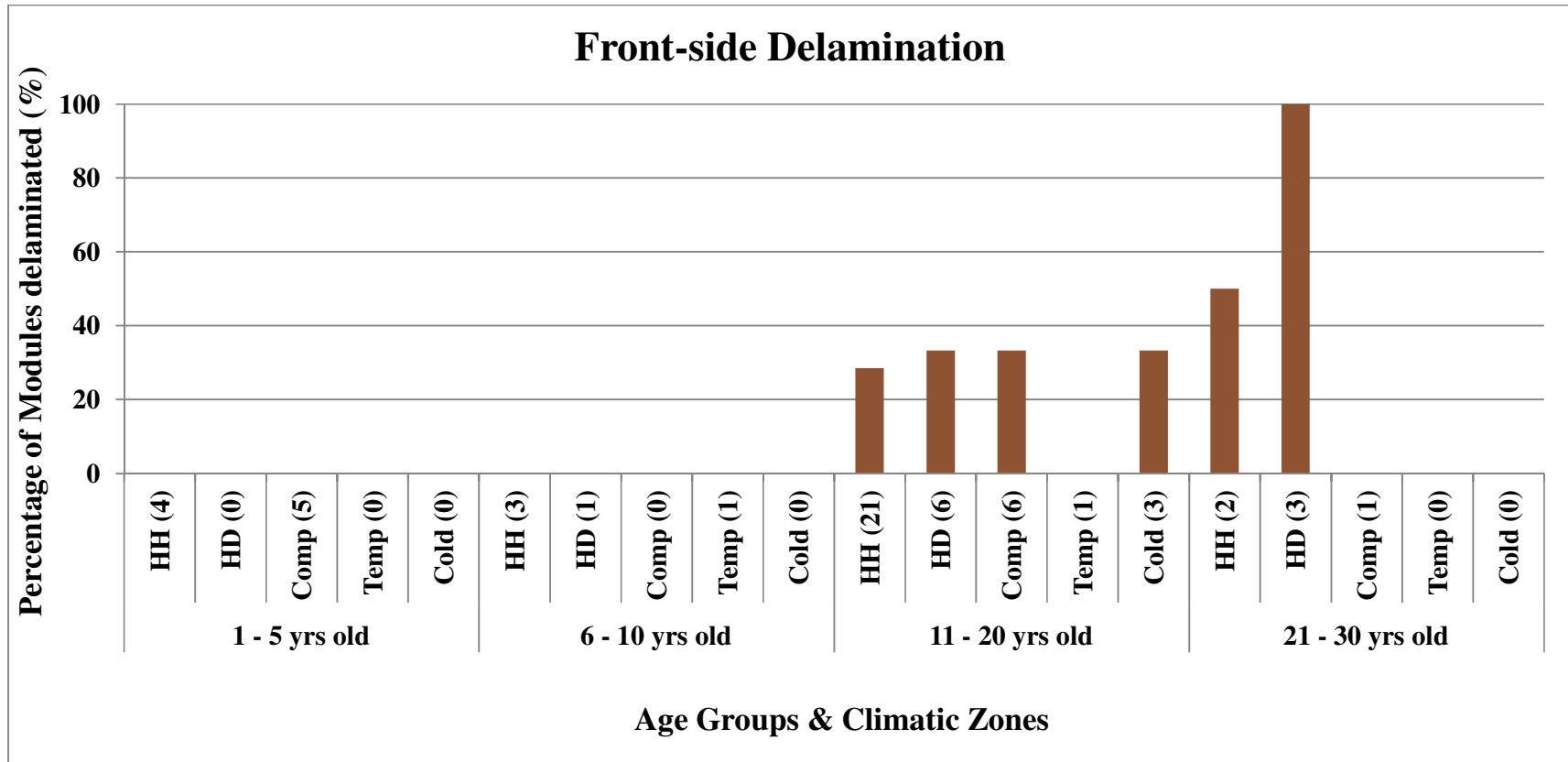

Fig. 8.14: Percentage of surveyed modules that have front-side delamination in the respective climatic zone & age group. The figures in bracket indicate the total sample size in that climatic zone for that age-group (“0” indicates no module sample).  
 HH: Hot & Humid zone, HD: Hot & Dry zone, Comp: Composite zone, Temp: Temperate zone, Cold: Cold zone

### 8.2.3 Discoloration (corrosion) of metallization, interconnects and output terminals

The term “metallization” refers to the fingers and busbars that crisscross the surface of the solar cell and gather the charge carriers for exporting outside of the module. The busbars in the various solar cells are interconnected using the interconnect ribbons. These metallization and interconnects should be low resistance paths so as to prevent voltage loss while conducting the current. However, it has been found that PV modules in the field suffer from corrosion in the long run, which increases the series resistance and lowers the output power of the module. Corrosion of the metallization can be inferred from the discoloration of the fingers and/or the busbars, but such visual identification becomes difficult if the encapsulant has also discolored (turned brown). The initial stages of corrosion in fingers can be seen in Fig. 8.14 whereas Figures 8.15 and 8.16 show some of the extreme cases of corrosion in the busbars.

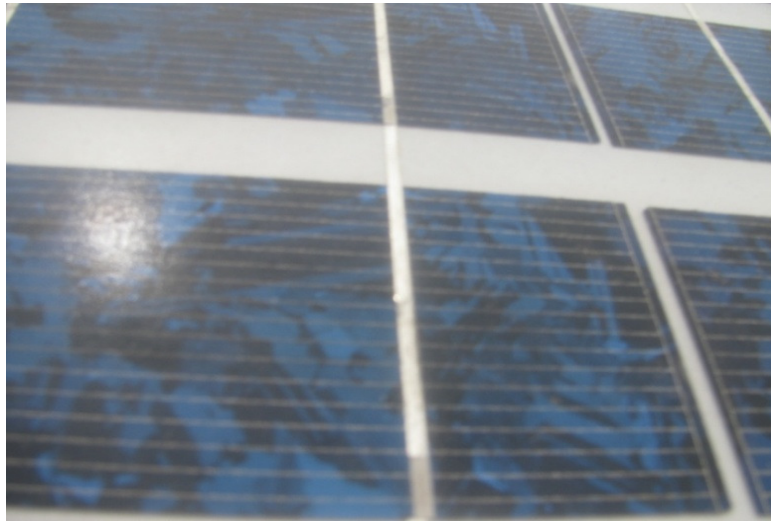

Fig. 8.15: Corrosion (discoloration) in fingers

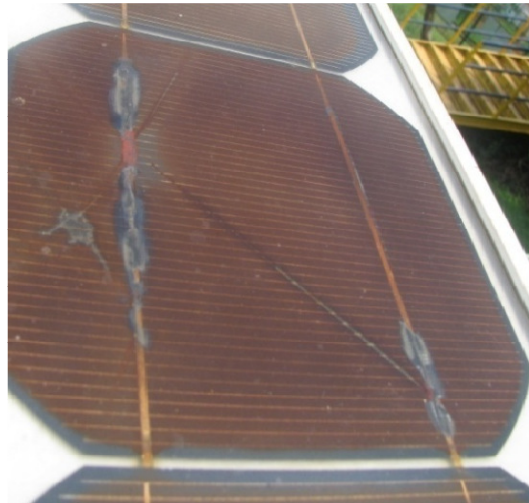

Fig. 8.16: Corrosion & burn marks on busbars & interconnects



Fig. 8.17: Corrosion (seen as red, green & black discoloration) in the string interconnect of a PV module installed in Hot & Dry zone in 1988.



Fig. 8.18: Corrosion in output terminals

ALL INDIA SURVEY OF PV MODULE DEGRADATION: 2013

In Table 8.4, one can straight away see that all inspected modules older than 20 years have corrosion, but among the younger modules also, corrosion is quite rampant. PV Modules placed in Hot & Humid zone appear to be most susceptible to corrosion of metallization & output terminals as compared to the other zones. Modules placed in the Cold & Dry climate of Ladakh have shown no or negligible corrosion. These results are not unexpected. These data has been presented graphically in Figures 8.19 and 8.20.

**Table 8.4: Percentage of modules effected by corrosion in various climatic zones (nos. in bracket indicate the sample size in respective zone)**

<b>Climatic Zone</b>	<b>1 – 5 yrs old</b>	<b>6 - 10 yrs old</b>	<b>11 - 20 yrs old</b>	<b>21-30 yrs old</b>
<b>Hot &amp; Humid</b>	50% (4)	33% (3)	100% (21)	100% (2)
<b>Hot &amp; Dry</b>	-- (0)	0% (1)	33% (6)	100% (3)
<b>Composite</b>	0% (5)	-- (0)	83% (6)	100% (1)
<b>Temperate</b>	-- (0)	0% (1)	100% (1)	-- (0)
<b>Cold</b>	-- (0)	-- (0)	33% (3)	-- (0)

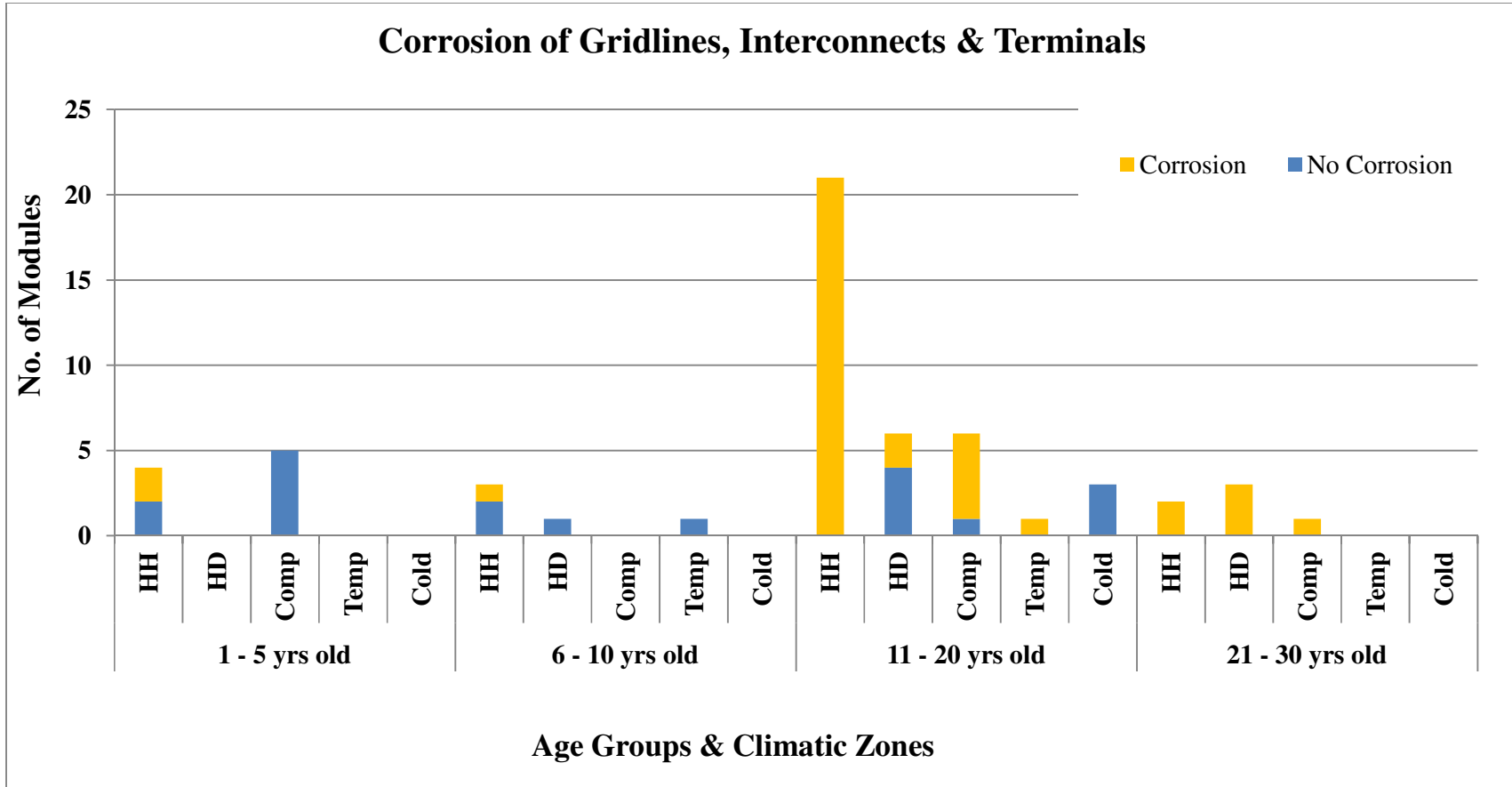

Fig. 8.19: Front-side delamination in modules in the respective Climatic Zones and Age groups.  
 HH: Hot & Humid zone, HD: Hot & Dry zone, Comp: Composite zone, Temp: Temperate zone, Cold: Cold zone

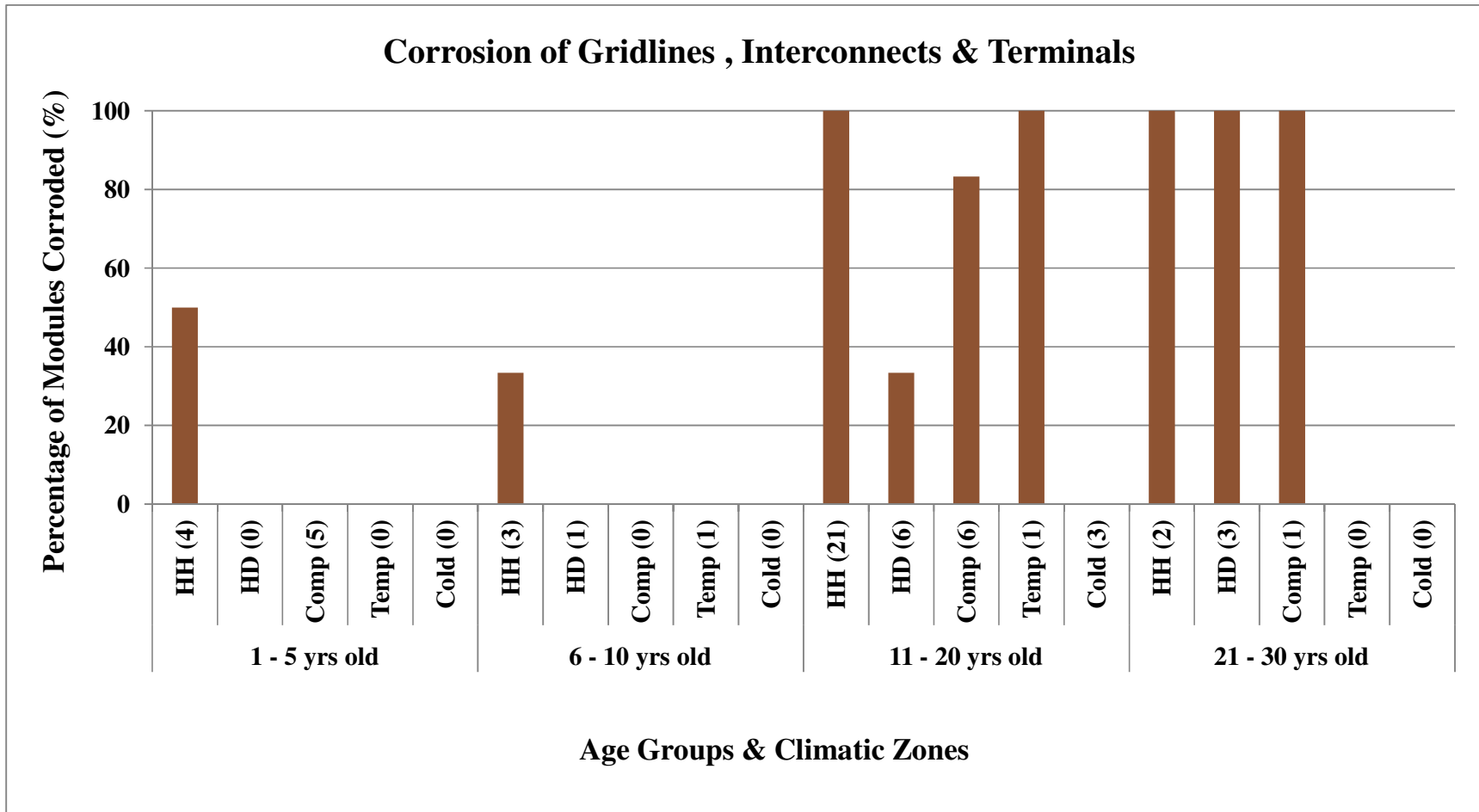

Fig. 8.20: Percentage of surveyed modules that have suffered corrosion in the respective climatic zone & age group. The figures in bracket indicate the total sample size in that climatic zone for that age-group (“0” indicates no module sample).  
 HH: Hot & Humid zone, HD: Hot & Dry zone, Comp: Composite zone, Temp: Temperate zone, Cold: Cold zone

### 8.2.4 Bubbles & delamination in backsheet

The backsheet provides physical protection to the solar cells against damage from backside, while also serving as a barrier layer for moisture and UV rays. It also provides electrical insulation, while allowing the heat generated inside the solar cells to escape to the environment. Degradation of backsheet like delamination and bubble formation (refer Fig. 8.21 below) can reduce the thermal conductivity at the site, which will in turn increase the operating temperature of the solar cells and may lead to hot spot formation, culminating in severe degradation in power output in the long run. Table 8.5 shows that bubbles and delamination has been seen in Hot & Humid zone and Composite zone, which hints that high humidity can aid in bubble formation. The percentage of affected modules is also quite low so it can be said that the bubble formation in back-sheet occurs in rare cases. Figure 8.22 shows the number of modules with and without bubbles and delamination, in bar graph, while Fig. 8.23 presents the percentage of affected modules.

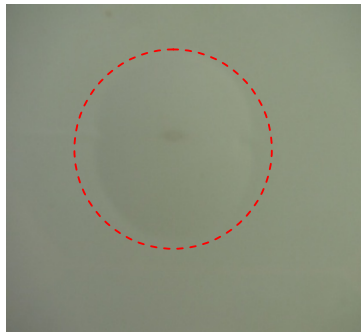

Fig. 8.21: Bubble in backsheet of a module (encircled in red dots)

**Table 8.5: Percentage of modules effected by bubbles & delamination in backsheet in various climatic zones (nos. in bracket indicate the sample size in respective zone)**

<b>Climatic Zone</b>	<b>1 – 5 yrs old</b>	<b>6 - 10 yrs old</b>	<b>11 - 20 yrs old</b>	<b>21-30 yrs old</b>
<b>Hot &amp; Humid</b>	0% (4)	0% (3)	24% (21)	50% (2)
<b>Hot &amp; Dry</b>	-- (0)	0% (1)	0% (6)	0% (3)
<b>Composite</b>	0% (5)	-- (0)	17% (6)	0% (1)
<b>Temperate</b>	-- (0)	0% (1)	0% (1)	-- (0)
<b>Cold</b>	-- (0)	-- (0)	0% (3)	-- (0)

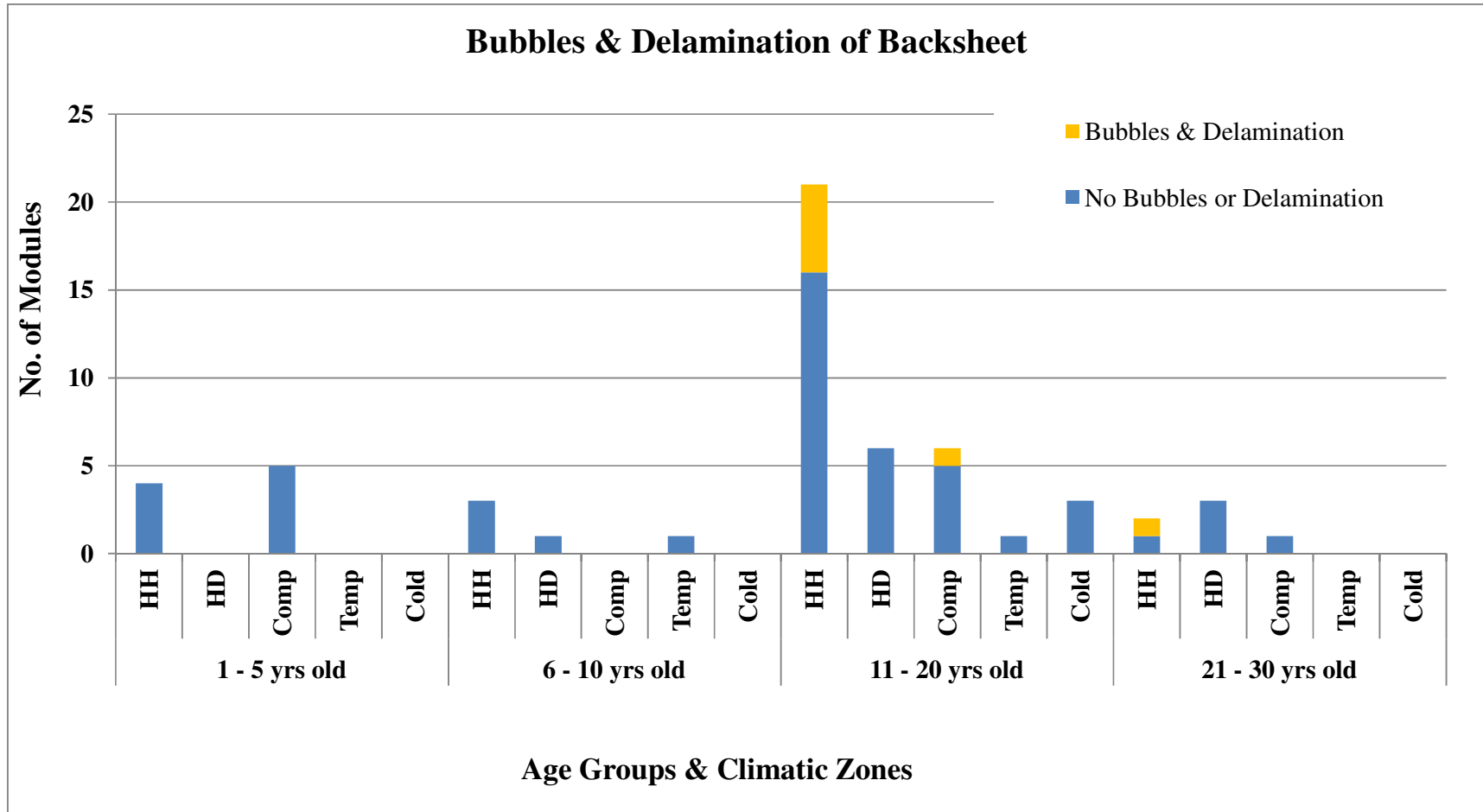

Fig. 8.22: Bubbles and delamination in module backsheet in the respective climatic zones and age groups.  
 HH: Hot & Humid zone, HD: Hot & Dry zone, Comp: Composite zone, Temp: Temperate zone, Cold: Cold zone

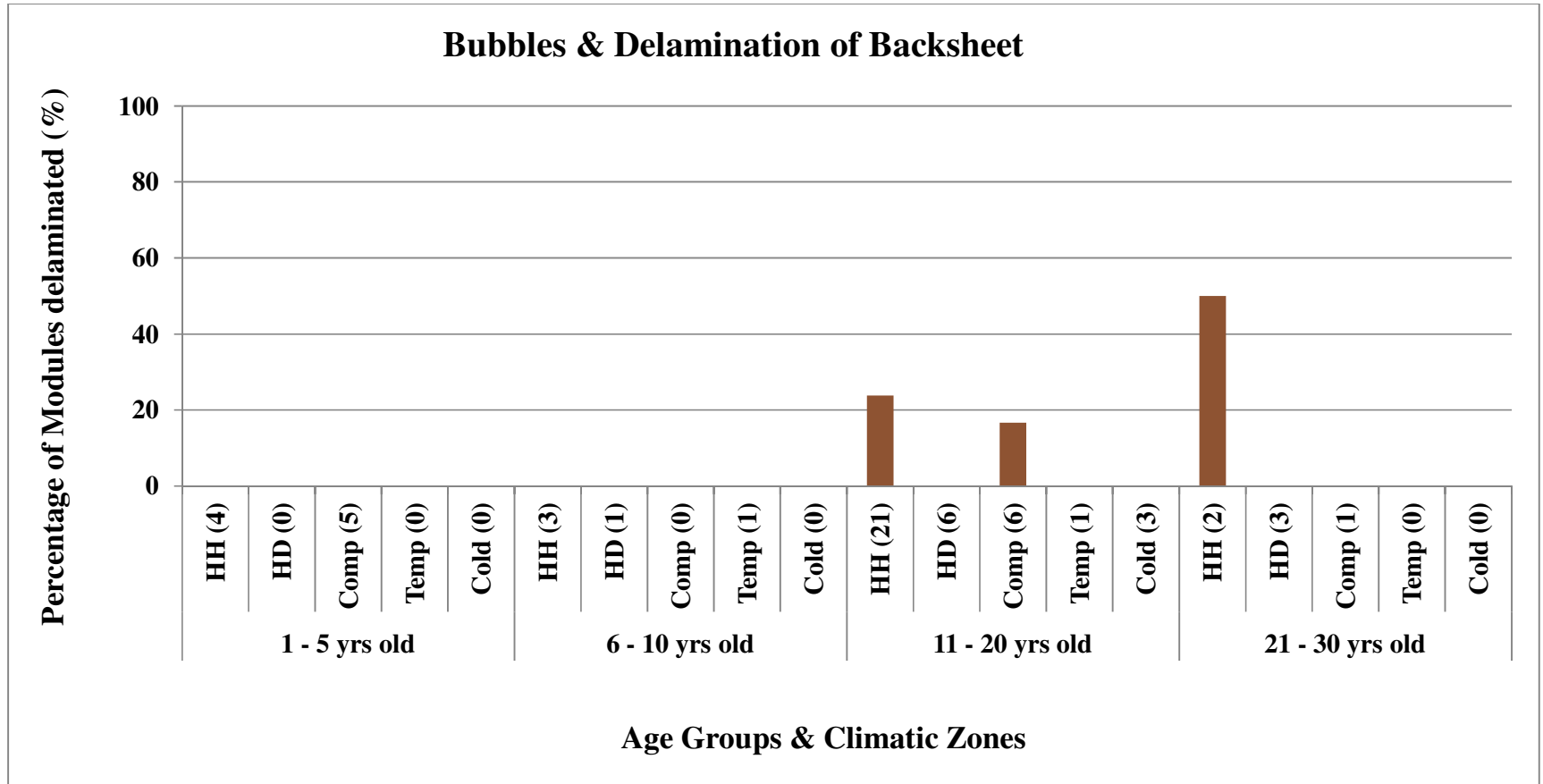

Fig. 8.23: Percentage of surveyed modules that have backsheet delamination and bubbles in the respective climatic zone and age group. The figures in bracket indicate the total sample size in that climatic zone for that age-group (“0” indicates no module sample).  
 HH: Hot & Humid zone, HD: Hot & Dry zone, Comp: Composite zone, Temp: Temperate zone, Cold: Cold zone

### 8.2.5 Chalking of backsheet

Chalking refers to the formation of a white powder from the backsheet (refer Fig. 8.24) due to the photo-thermal degradation of the back-sheet polymer. Table 8.6 shows that chalking has been found only in some modules in the 11 – 20 years age bin (and not in other age groups). Modules older than 20 years did not show chalking, which hints that the backsheet material might have been changed by the PV module manufacturers about a decade back. Chalking has been seen in all climatic zones except the cold zone, where the low temperatures prevent thermal degradation of the backsheet. Figure 8.25 presents graphically the actual data collected during the survey, while Figure 8.26 presents the percentage of affected modules in the various climatic zones.



Fig. 8.24: White powder from backsheet of a module

**Table 8.6: Percentage of modules having powder on backsheet in various climatic zones (nos. in bracket indicate the sample size in respective zone)**

Climatic Zone	1 - 5 yrs old	6 - 10 yrs old	11 - 20 yrs old	21-30 yrs old
<b>Hot &amp; Humid</b>	0% (4)	0% (3)	19% (21)	0% (2)
<b>Hot &amp; Dry</b>	-- (0)	0% (1)	67% (6)	0% (3)
<b>Composite</b>	0% (5)	-- (0)	33% (6)	0% (1)
<b>Temperate</b>	-- (0)	0% (1)	100% (1)	-- (0)
<b>Cold</b>	-- (0)	-- (0)	0% (3)	-- (0)

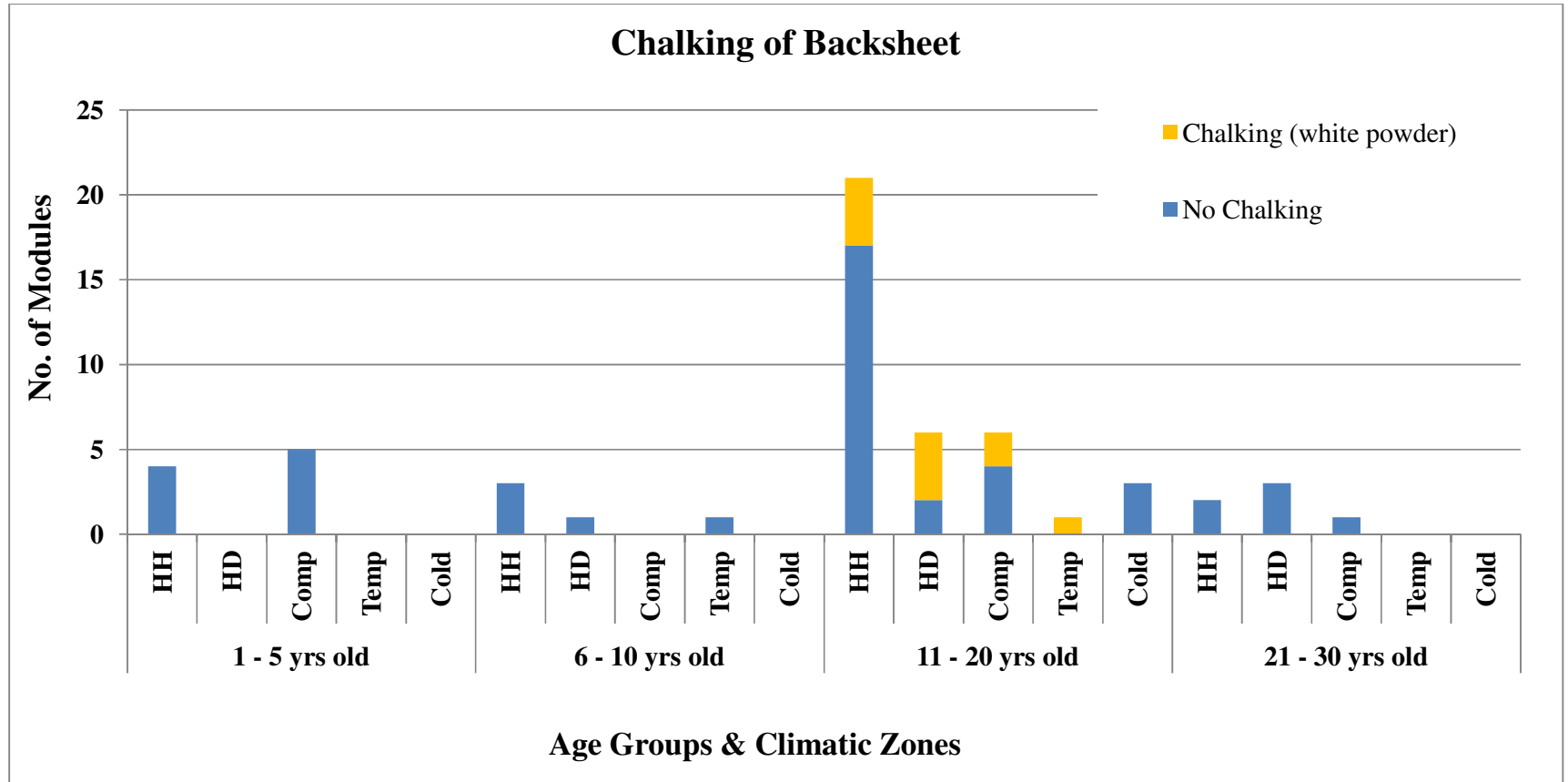

Fig. 8.25: Chalking in Module Backsheet in the respective climatic zones and age groups.  
 HH: Hot & Humid zone, HD: Hot & Dry zone, Comp: Composite zone, Temp: Temperate zone, Cold: Cold zone

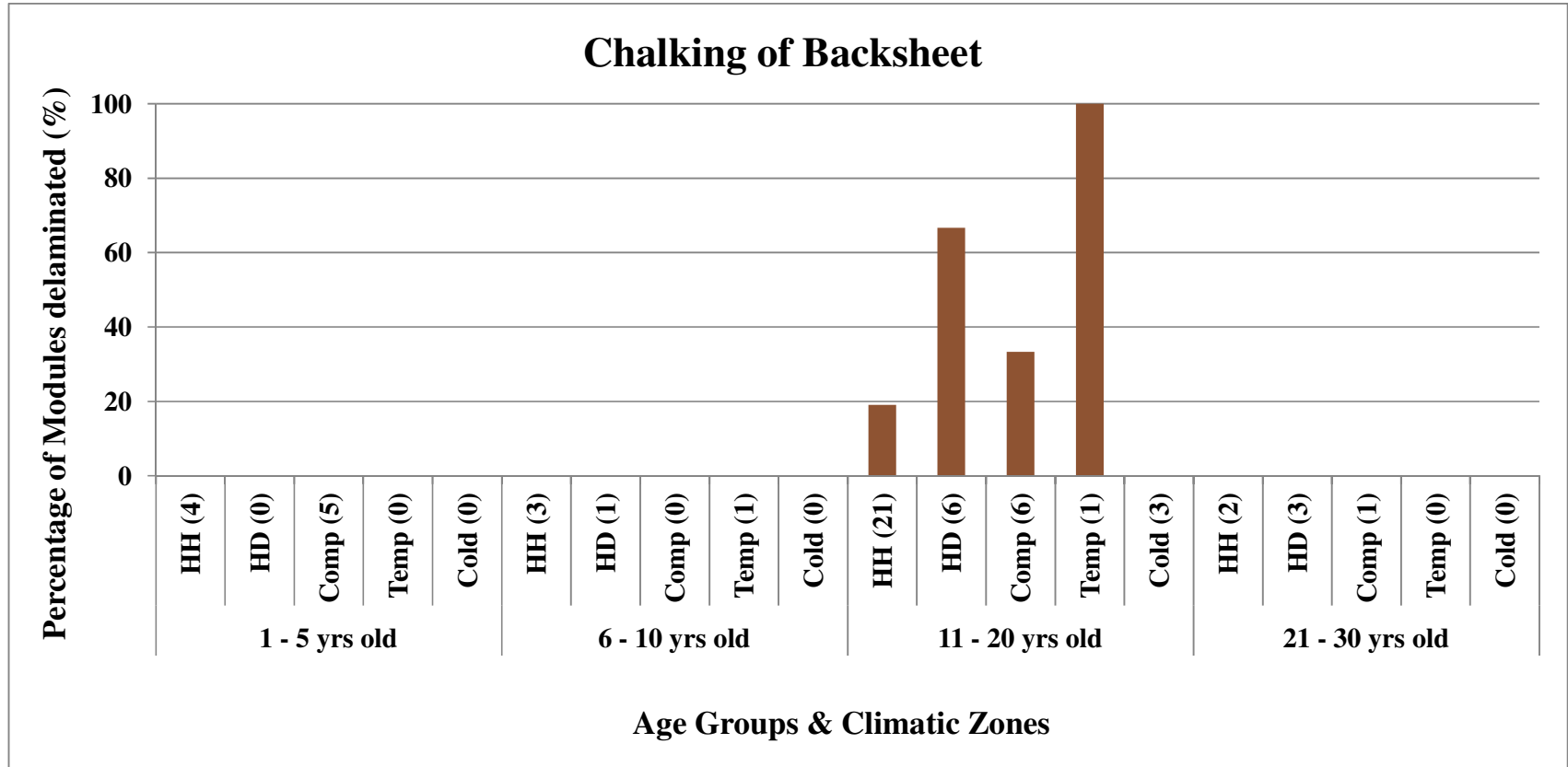

Fig. 8.26: Percentage of surveyed modules that have backsheet delamination & bubbles in the respective climatic zone & age group. The figures in bracket indicate the total sample size in that climatic zone for that age-group (“0” indicates no module sample).  
 HH: Hot & Humid Zone, HD: Hot & Dry Zone, Comp: Composite Zone, Temp: Temperate Zone, Cold: Cold Zone

### 8.2.6 Junction box damage

The junction box houses the output terminals of the PV module and the by-pass diodes and protects these from ingress of water and dust. If the structure of the junction box is compromised or the sealing is not appropriate, rain water can reach the terminals and corrode them (refer Figs. 8.27 and 8.28), leading to higher series resistance and lower power output. The survey data presented graphically in Figs. 8.29 and 8.30 indicate that the junction box structure was unsound in 22% of the cases, and the sealing of the junction box was poor in 24% of the cases.



Fig. 8.27: Junction box with no sealing, which has lead to corrosion of output terminals and Bypass Diodes



Fig. 8.28: Junction box with good sealing, which has prevented corrosion of output terminals and Bypass Diodes

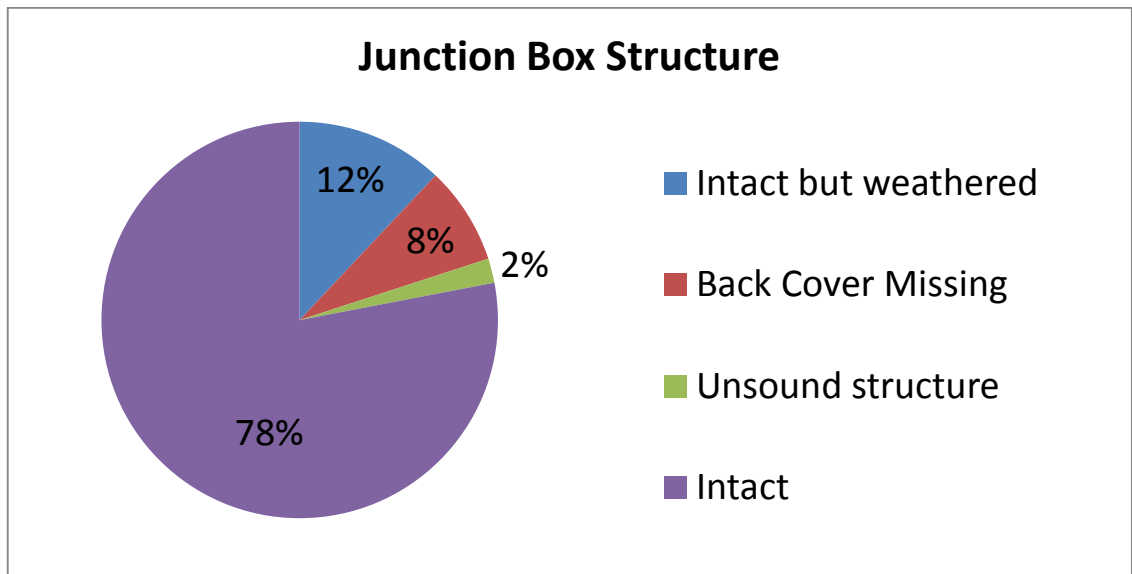

Fig. 8.29: Condition of Junction Box structure

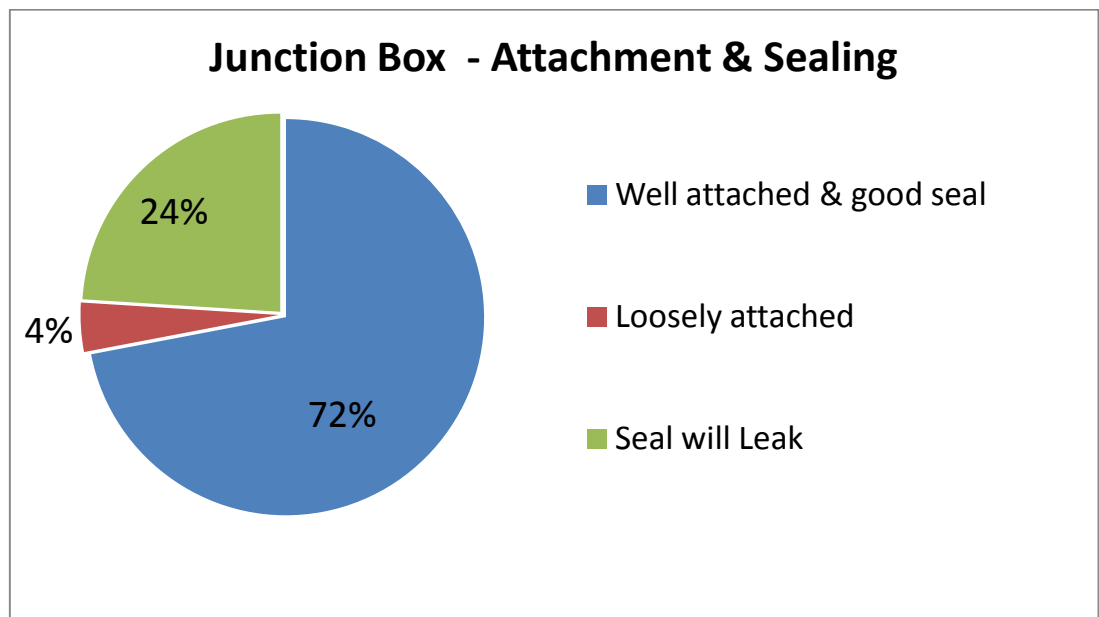

Fig. 8.30: Condition of Junction Box Attachment & sealing

### 8.2.7 Frame damage

The frame plays a major role in keeping the different layers of the PV module together and provides mechanical strength and rigidity. Minor damage to the frame alone may not cause any short-term degradation in the PV module, but in the long term, such damage can progress to a state where the outside environment (water and/or dust) can gain access to the solar cells and cause reduction in power output. Figure 8.31 shows an extreme case of frame damage while Fig. 8.32 shows corrosion

(blackening) of the frame edges. Figure 8.33 shows that close to 40% of the modules had some kind of damage or corrosion in the frame. Further, only 26% of the modules had proper grounding of the frame, and among these, 14% modules had the grounding connection disconnected from ground. Grounding of the frame can protect people touching the module from electric shock in the event of failure of insulation of the PV module.



Fig. 8.31: Corroded and dented frame of a PV module

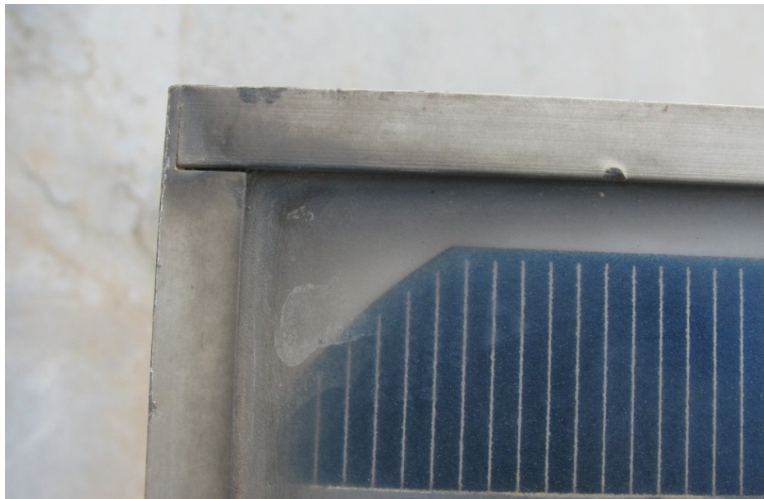

Fig. 8.32: Corrosion (blackening) of the frame of a PV module

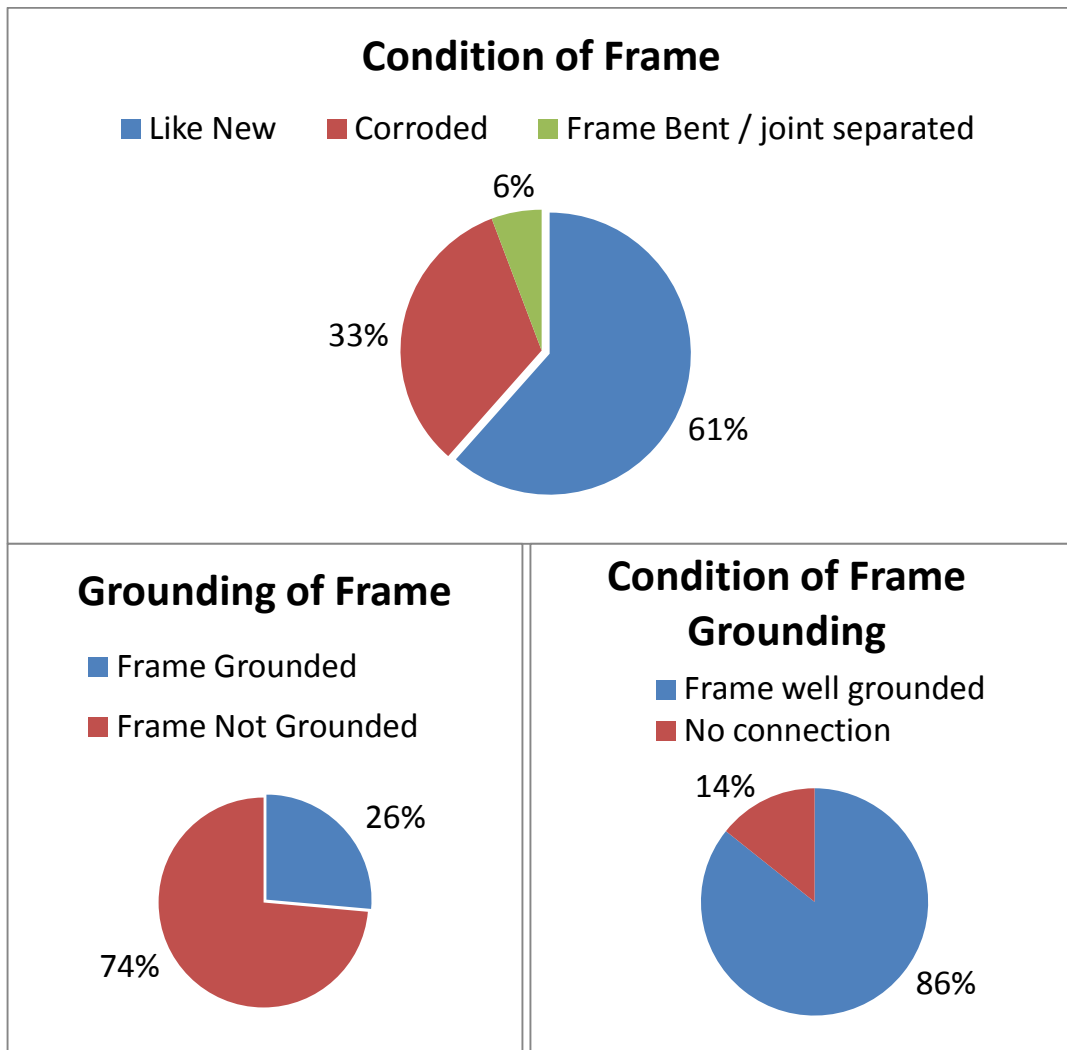

Fig. 8.33: Condition of frame and frame grounding connection

### 8.3 Visual Degradation Modes Observed in the Thin Film Modules

Six nos. of thin film modules were inspected during the survey, at 2 different sites – one module of amorphous silicon triple-junction technology and one CIGS module in Hot & Humid zone and another 4 modules (1 no. CIS and 3 nos. amorphous silicon technology) in Composite zone. Out of these, only one module had glass on the rear side, whereas the rest had some kind of polymer. Since the sample size is very small and restricted to just two climatic zones, we would only present the findings of individual modules and would not compare across climate zones or age-groups.

### 8.3.1 Degradation in the CIGS modules

#### 8.3.1.1 CIGS module in Hot & Humid climate

We have investigated a CIGS module installed in Pune in 2009. In spite of being only 3 years old, the module was showing light yellow discoloration in some portions, as can be seen in Fig. 8.34. The module was otherwise free of any deterioration.



Fig. 8.34: Light yellow discoloration seen in CIGS module

#### 8.3.1.2 CIS module in Composite climate

A CIS module installed around 13 years ago was investigated in Haryana (refer Fig. 8.35). Fig. 8.36 shows dark patches near the electrodes of the module and there was also a puncture in its backsheet (shown in Fig. 8.37). White deposits could be found on its bottom edges near the frame, as visible in Fig. 8.38. On cleaning the module with water, we could see white powder (salts) settling on top of the module. It appears that the hardness of the ground water used for cleaning of the modules is causing the white deposits.



Fig. 8.35: 13 years old CIGS Module installed in Composite climate



Fig. 8.36: Dark patches close to electrode of CIGS module



Fig. 8.37: Puncture in the backsheet of the CIGS module



Fig. 8.38: White deposits (salts) at the edges of the CIGS Module

### 8.3.2 Degradation in the amorphous silicon modules

### 8.3.2.1 Amorphous silicon double tandem modules

Three (3) nos. of 13-year old amorphous silicon double tandem modules (with glass on both front & rear sides) were inspected at a site in Composite zone. One of the modules had suffered corrosion whereas another module was still intact and without such extensive corrosion, as shown in Fig. 8.39. The corroded module also suffered from cracks in the glass near the bottom edge of the module (refer Fig. 8.40). These cracks could have been responsible for the corrosion by letting moisture and rain water enter into the module. This module also showed similar corrosion near the top edge where the current-carrying electrodes terminate. The degradation in the electrical parameters of this module has been presented in Chapter 7. Carlson *et al.* [62] have reported that this type of corrosion (called “bar graph corrosion” due to the shape of the corroded portion) is due to the migration of sodium ions from the glass substrate in the presence of a potential gradient across the glass thickness. A possible preventive measure would be to maintain the TCO at a positive voltage with reference to the ground.

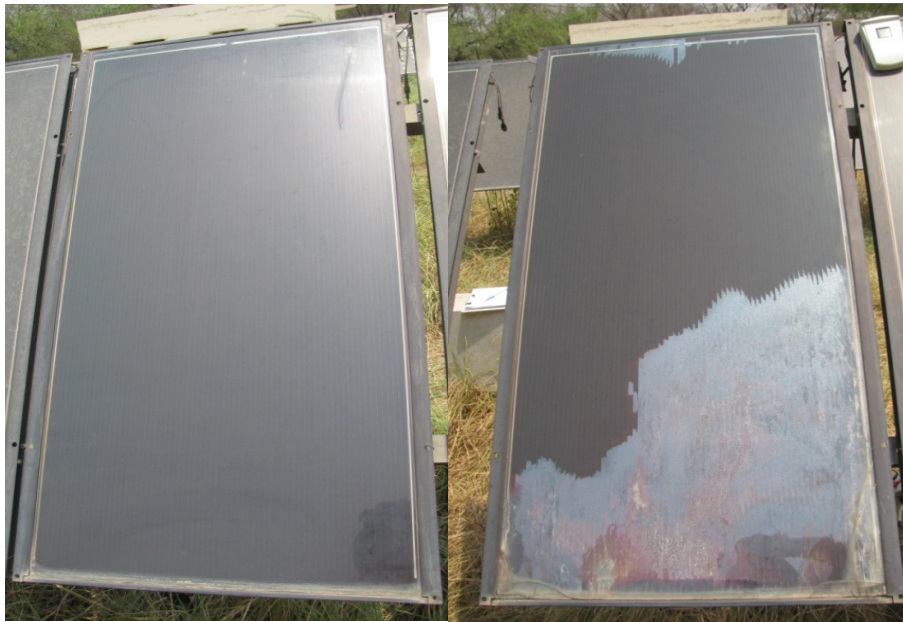

Fig. 8.39: Bar-graph corrosion in amorphous silicon double tandem PV module



Fig. 8.40: Cracks in the glass of the corroded module

Figure 8.41 shows a close-up view of the corroded portion of the module from the backside. Infrared thermograph of this module is shown in Fig. 8.42 (left side). The IR camera has identified the hottest and the coldest parts in its field of view, marking their positions as “Max” and “Min”, and colour-coded the temperatures of all the parts from black (indicating lowest temperature) to white (indicating highest temperature). In this colour coding, blue is cooler than red. The lower portion of the Infrared image (left hand side picture) corresponds to the corroded part of the module, and as we can see, it is cooler than the rest of the module. The top portion of the module is the hottest.

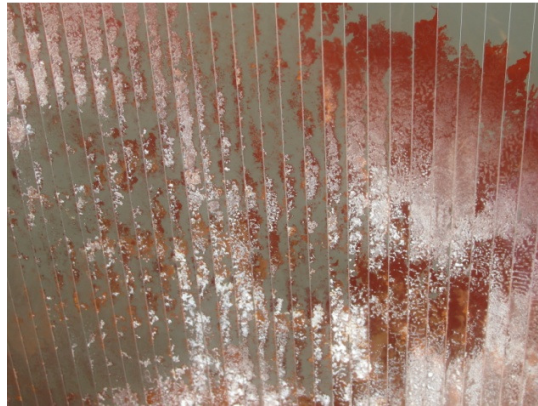

Fig. 8.41: Corroded portion of the module (image from backside)

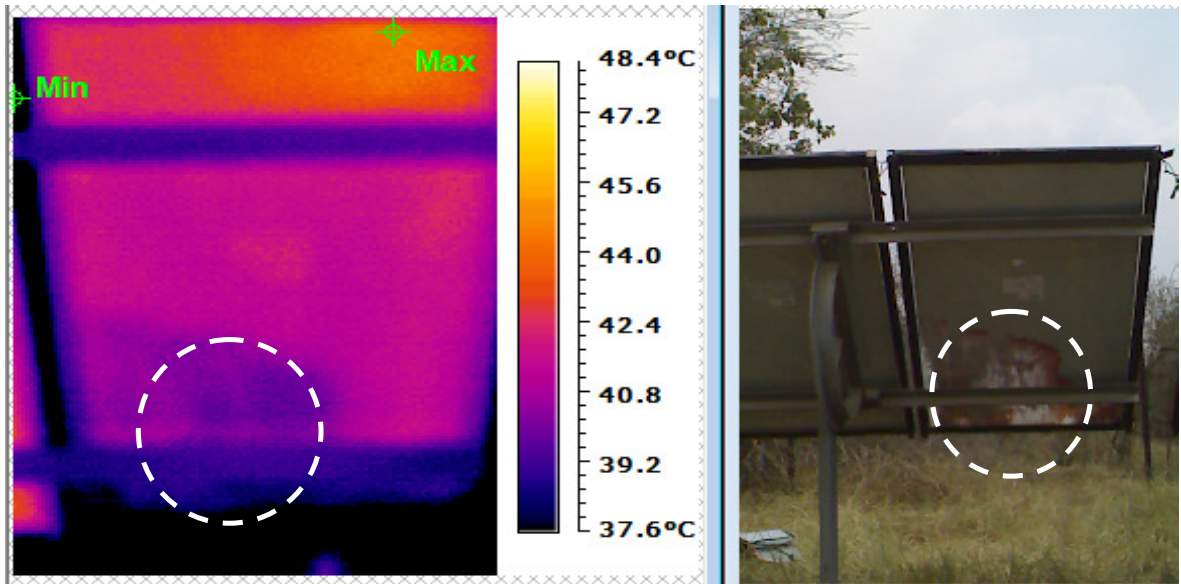

Fig. 8.42: Infra-red image (left side) of the corroded module shows that the corroded portion (blue patch near the bottom) is the coldest in the module.

### 8.3.2.2 Amorphous silicon triple tandem modules

An 11-year old amorphous silicon triple tandem module was inspected at the same site in Composite zone. This module had a certain type of polymer at the top. There were strange tracks on the module, as if some snail or other insect has walked on it (refer Fig. 8.43). These tracks could not be removed by cleaning using a wet cloth. The infra-red image of the module showed that the snail track is operating at a higher temperature than the adjoining areas (Fig. 8.44). Some punctures were also noticed on the top fabric (Fig. 8.45).



Fig. 8.43: Triple tandem amorphous silicon module with “snail trails”

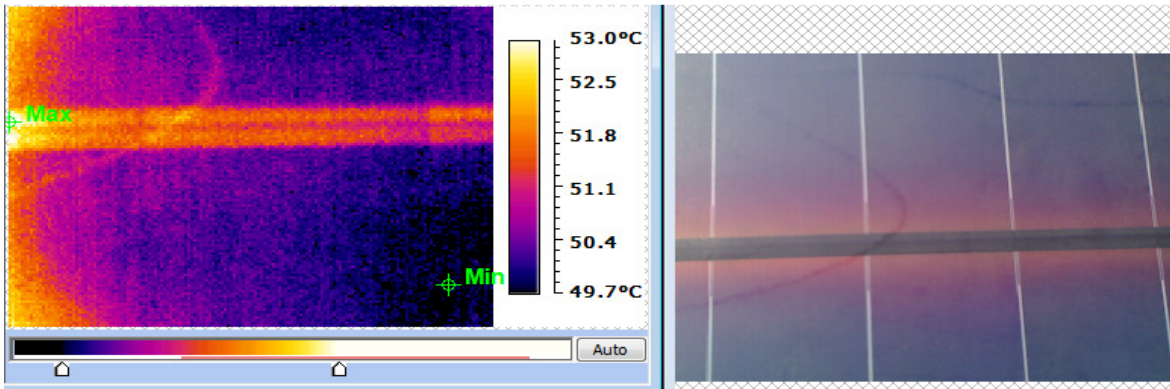

Fig. 8.44: IR image of the module showing that the snail trail is operating at higher temperature than the adjoining areas



Fig. 8.45: Puncture marks on the module top fabric

A triple tandem amorphous silicon module was also inspected in Kerala which falls in Hot & Humid climatic zone. This module is similar to the module shown above, in terms of construction (refer Fig. 8.46), and is just 6 months old. The top layer of this module suffered damage at some localized places as shown in figure 8.47.



Fig. 8.46: 6-month old amorphous silicon triple tandem module

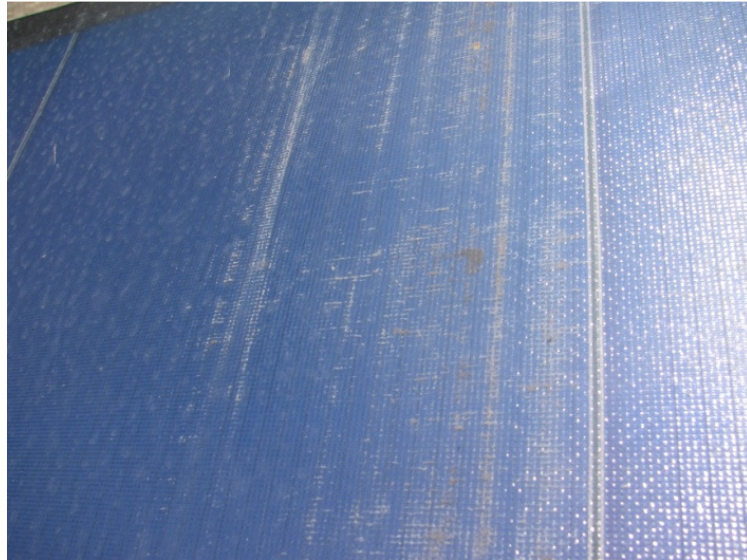

Fig. 8.47: Damaged surface of the triple tandem a-Si module

## 8.4 Correlation between Visual and Electrical Degradation

### 8.4.1 Discoloration of encapsulant

The primary impact of discoloration of the encapsulant is reduction of the short circuit current of the module which consequently also reduces the power output of the module. The percentage degradation in short circuit current (and other electrical parameters) has been calculated for all modules and the analysis of the data has been presented in Chapter 7. An effort is being made here to correlate the degradation in short-circuit current ( $I_{sc}$ ) with the degree of discoloration of the encapsulant. Discoloration of EVA is a continuous process, which starts with light yellow colour and then slowly increases in darkness and becomes dark brown in the long run. On a qualitative basis, we have taken colour shades close to yellow as “light” discoloration, while colour shades close to brown have been taken as “dark” discoloration, but there is no strict quantitative demarcation. Also the affected area of the module has been considered in deciding the category of discoloration. In Fig. 8.48, the percentage degradation in short-circuit current ( $I_{sc}$ ) is shown for different categories of discoloration (light/yellow or dark/brown, coupled with affected area of module), with the figures in bracket indicating the median value (refer Chapter 5). The percentage degradation of  $I_{sc}$  has been calculated by taking the difference of the present  $I_{sc}$  value (corrected to STC) and the name-plate  $I_{sc}$  rating and dividing this ratio by the name-plate rating (also refer Chapter 7 for electrical parameter degradation):

$$\% I_{sc} \text{ Degradation} = \frac{I_{sc,nameplate} - I_{sc,present}}{I_{sc,nameplate}} \times 100 \% \quad \dots (8.1)$$

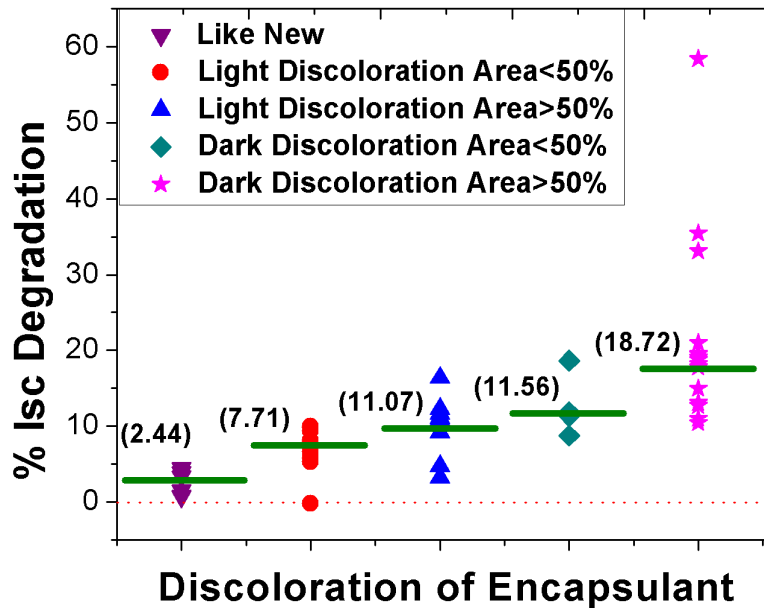

Fig. 8.48: Correlation between  $I_{sc}$  degradation and discoloration of EVA

As evident from the Fig 8.48, there is a direct relation between the discoloration of the encapsulant and the percentage short-circuit current degradation. In the literature, it has been reported that the yellowing of EVA (upon exposure to high temperatures for long duration) reduces the transmission spectra of the degraded EVA. Shuying Yang and Kent Whitfield [32] have computed the short-circuit current corresponding to different stages of discoloration of EVA (based on the changed transmission spectra of the EVA and the quantum efficiency of solar cells) and found that it would reduce linearly with the increase of the Yellowness Index (degree of browning) of the EVA [32]. Our field data is in general agreement with the reported literature in a qualitative way, though we could not quantify the extent of yellowing as we did not have any tools to measure the yellowness index of the modules in the field during the survey.

#### 8.4.2 Corrosion in the metallization, interconnects and terminals

Corrosion of the current-carrying metallic conductors in the modules affects the series resistance of the module, which in turn will lower Fill Factor (FF) and also the power output of the module. We have made an effort to correlate the series resistance of the surveyed modules with the degree of corrosion observed in the field. The electrical I-V data of the modules have been extrapolated to the standard test conditions. Then the slope of the I-V curve near the open circuit voltage point (where

current nearly zero) has been calculated from the extrapolated data and the inverse of the slope gives us an indicative value of the series resistance (refer Fig. 8.49).

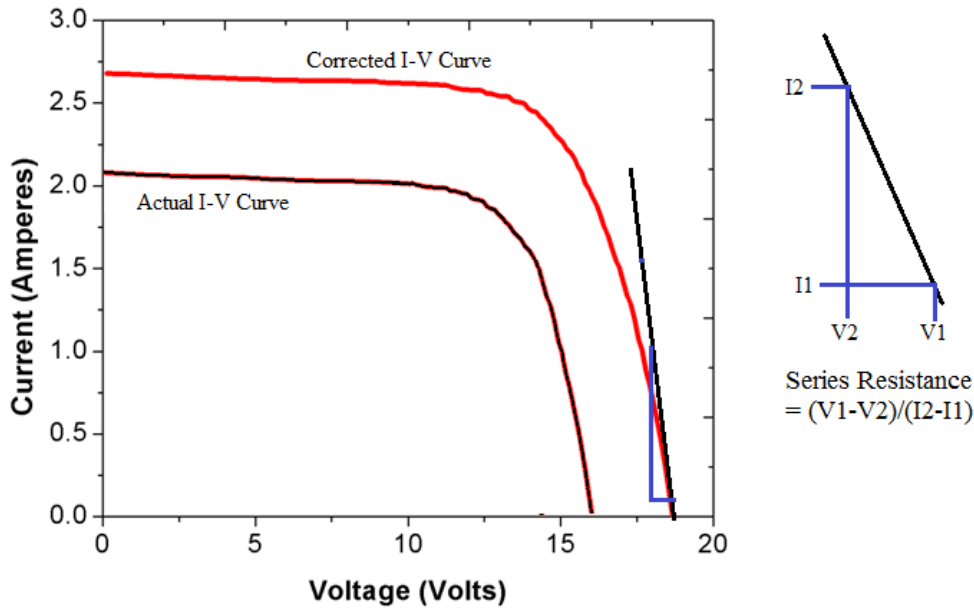

Fig. 8.49: Calculation of Series Resistance from PV module I-V curve

The series resistance of the modules is plotted against the level of corrosion of the surveyed crystalline silicon modules in Fig 8.50. The level of corrosion is estimated on a qualitative basis since it's not practically possible to physically measure the extent of corrosion in the PV module in the field. The median value of series resistance for surveyed modules with no apparent corrosion is  $0.85 \Omega$  whereas it is greater than  $1 \Omega$  for all cases (significantly higher in some cases) with corrosion in metallization and/or output terminals. The gradual increase in series resistance with higher levels of corrosion can be easily seen from Fig. 8.50.

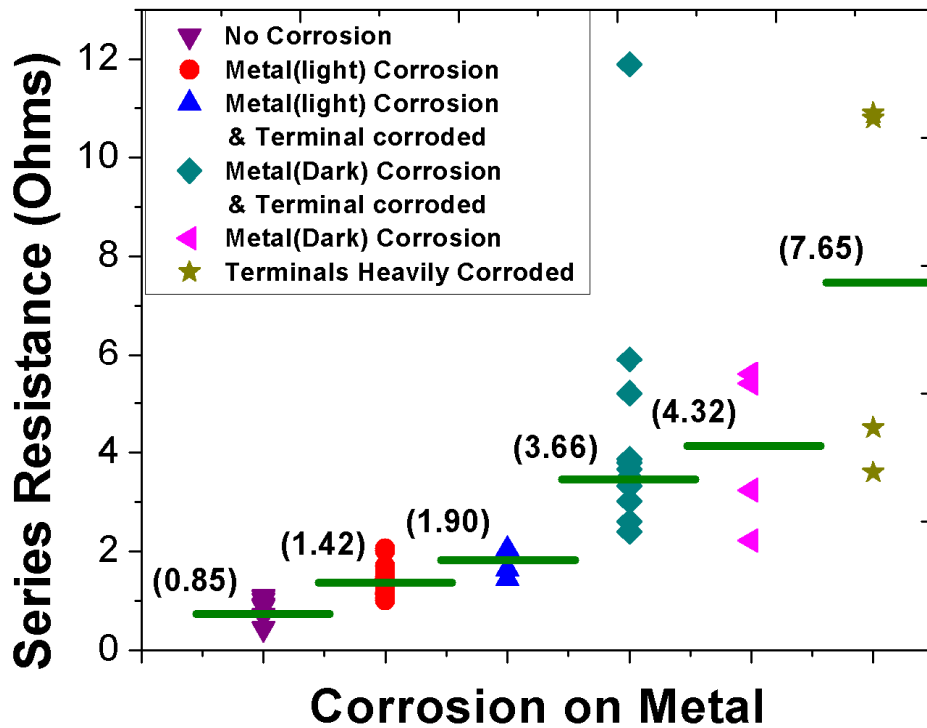

Fig. 8.50: Relation between corrosion and series resistance

### 8.4.3 Delamination

Delamination in the PV modules increases the thermal resistance of the affected areas, which can reduce the cooling rate and cause the affected areas to operate at higher temperatures than the surroundings. This in turn may lead to Hot Spots which can accelerate the degradation of the solar cells. Figure 8.51 shows the  $I_{sc}$  degradation rates of modules with and without delamination, and we find that the delaminated modules have suffered higher rates of degradation as compared to modules without delamination. A similar trend is seen in Fig. 8.52 which plots the  $I_{sc}$  degradation rates for modules with and without delamination. The reason behind higher  $I_{sc}$  degradation may be the increased reflection of light from the affected zone. Shioda [38] has shown similar observation for field aged modules having delaminated solar cells.

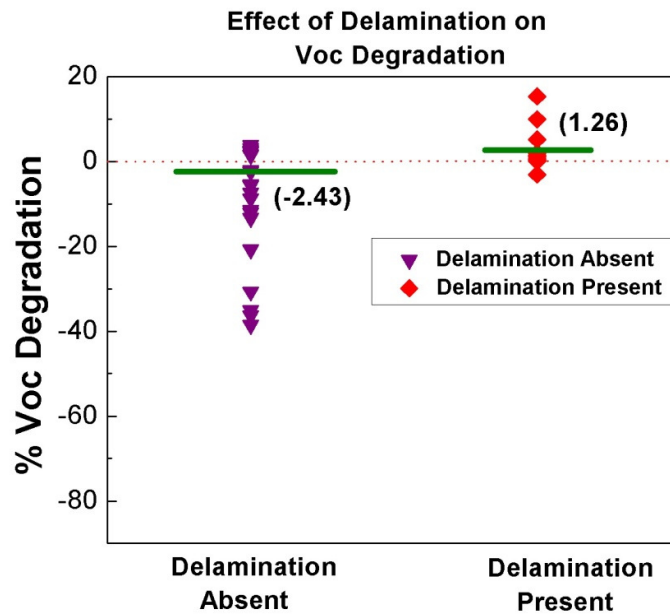

Fig. 8.51: Effect of delamination on degradation of Open circuit voltage

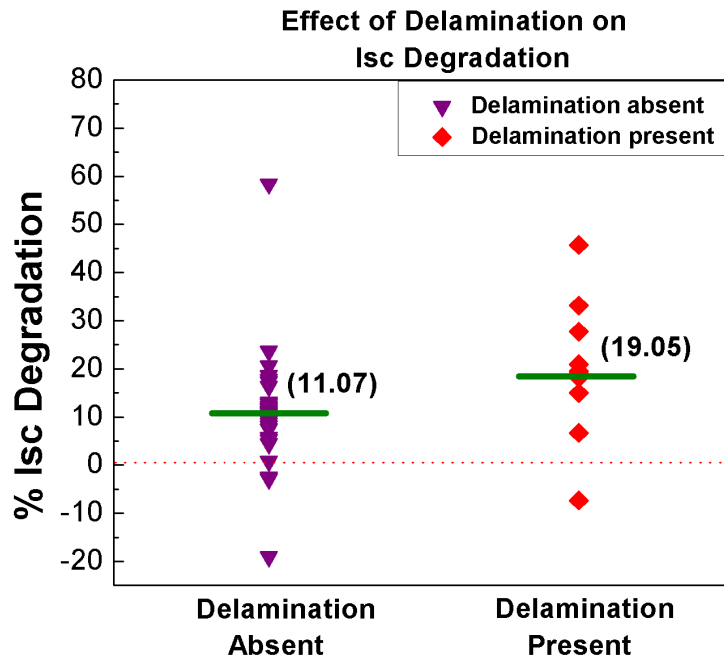

Fig. 8.52: Effect of delamination on degradation of short circuit current

## 8.5 Champion Modules

In the survey, we came across some modules that showed very little signs of degradation and the analysis of their electrical data showed that these modules were degrading at a very slow rate (less

than 0.2% per year while present-day PV module warranty corresponds to a  $P_{max}$  degradation rate of 0.8% per year). These modules can be considered as Champion Modules and a detailed analysis of such modules can provide us the pathway towards improving the PV module lifetime. Some of these modules are shown in the Fig. 8.53 below along with the  $P_{max}$  degradation rate (calculated based on formula given in Chapter 7). The excellent performance of the PV module with the shattered glass indicates that development of encapsulants permeable to gases (while impermeable to moisture whose ingress may cause corrosion problems) may improve the durability of the modules. Modules of a certain manufacturer were found to be performing much better than those of other manufacturers. It is possible that the materials and/or the manufacturing process used by this manufacturer can lead us to the goal of achieving 35 year lifetimes of PV Modules.

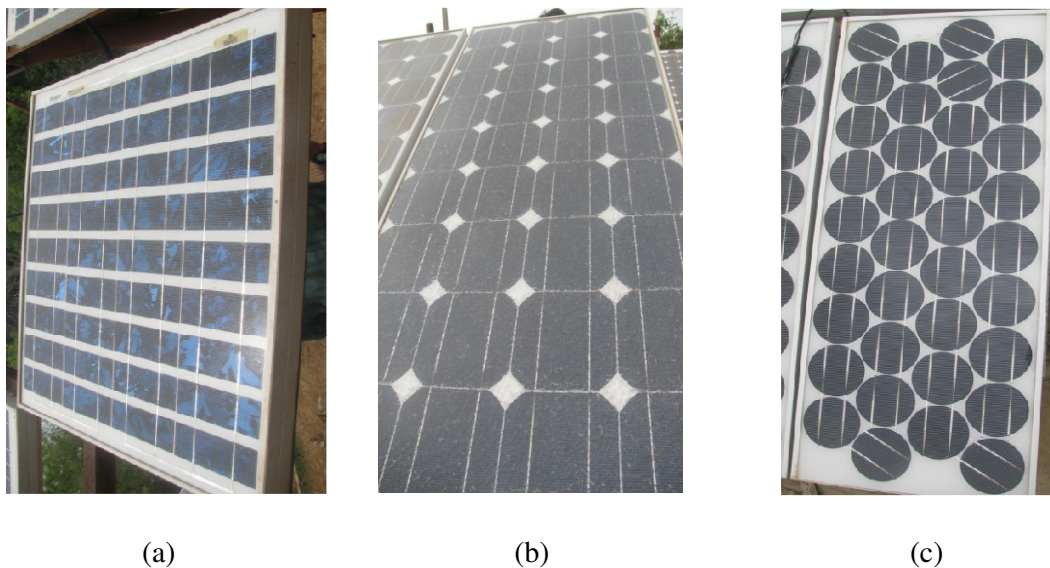

Fig. 8.53: (a) 7 year old PV Module (placed in Hot & Humid climate) showing no degradation in  $P_{max}$   
 (b) 15 year old PV Module (placed in Hot & Humid climate) with shattered front glass having  $P_{max}$  degradation rate of 0.05% per year,  
 (c) 15 year old PV Module (placed in Cold climate) having degradation rate of  $P_{max}$  degradation of 0.12% per year

## 8.6 Conclusions

Visual degradation of PV modules can provide us hints about the degradation of electrical parameters, particularly the power output. Discoloration of encapsulant and corrosion in

metallization and output terminals have been found to be the most common types of visual degradation observed in this survey.

The highest percentage of modules suffering from discoloration was found in the Hot & Dry zone, followed by the Hot & Humid zone. Overall, modules placed in the Hot zones appear to be more prone to discoloration than in other zones of the country. Discoloration of encapsulant is a major factor in reducing the short-circuit current, and hence the power output. There are various ways of preventing or retarding the discoloration of the encapsulant, but a disheartening observation in the survey has been that some of the new modules (installed less than 3 years ago in Hot & Humid zone) have already started yellowing.

Another factor that has a significant effect on the power output is the series resistance. Corrosion of the metallization, interconnect ribbon and the output terminals increases the series resistance, leading to a deterioration of the fill factor and ultimately the power output. Modules placed in the Hot & Humid zone are most prone to corrosion, while modules in the Cold & Dry climate of Ladakh are the least affected. The corrosion of the output terminals can be prevented by using proper sealing in the junction box, but 24% of the modules surveyed lacked proper sealing. Module manufacturers should take care to use properly sealed junction boxes for modules going to be placed in the high humidity zones (Hot & Humid zone and Composite zone).

Delamination on the front side, below the front glass, can also cause loss in power output, since it has been found to increase the deterioration of the open circuit voltage. However, only modules older than 10 years have shown delamination and only a small fraction of modules in that category have actually been affected, so it may be inferred that delamination is no longer a major reliability issue. Delamination and bubbles in the backsheet have only been observed in Hot & Humid zone and Composite zone, which implies that high humidity can be one of the factors responsible for bubble formation.

There are certain types of degradations (like breakage of top glass cover, denting of the frame etc.) which do not directly impact the power output, but can pose serious safety concerns. About 40% of the modules surveyed had some kind of degradation of the frame and only 26% had frame grounding connection. In the thin film modules, having glass-glass construction, cracks in the glass resulted in “bar graph corrosion” in the module, which reduced the power output significantly. Some of the thin film modules used special types of polymeric front cover, but often this cover suffered puncture or abrasion.

Module degradation has been the least in the Cold climate of Ladakh. The solar irradiance during our stay in Ladakh was quite high, reaching  $1100 \text{ W/m}^2$  on some occasions. The combination of high solar irradiance and low ambient temperatures, coupled with the negligible degradation of modules, makes Ladakh one of the best places in the country to install photovoltaic panels. It has been recently reported that a 220 KV transmission line will be built to connect Ladakh to the national electricity grid [63]. Once this transmission line is completed, it would make it possible to set up mega-watt scale power plants in Ladakh and sell the power to the national grid, there by utilizing the vast arid landmass of Ladakh and bring revenues to an economically weak state.

In the following chapter, we shall present the socio-economic analysis of the survey data which will show how the installation and maintenance of the systems is related to the motivation and economic status of the owner.



## 9. Socio-Economic Perspective

---

### 9.1. Introduction

In the last two chapters, we have looked at the degradation rates as a function of climatic conditions, and also for various technologies. Module degradation may also be related to non-technical aspects like social and behavioural issues of the end users. There can be different possibilities of module degradation due to negligence in maintenance and cleaning, or improper installation and use of the modules. An analysis on the surveyed systems, irrespective of the climatic zones, with this different perspective, has also revealed some information.

### 9.2. Framework for Analysis: Categorization of Surveyed PV Installations

A framework for analysis has been designed based on the insights obtained from the literature on socio-economic analysis of PV projects around the world, as explained in Chapter 2. The surveyed systems were categorised based on three aspects – type of ownership, financial model and the purpose of installation. A comparison of the appropriateness of installation, nature and frequency of maintenance activities and the linkages between these two parameters with ownership, financial model and purpose of installation was performed.

#### 9.2.1. Categorization based on types of ownership

Here we have tried to analyse the maintenance activities and condition of the PV systems based on the kind of ownership. Generally we have divided the kind of ownership into 4 categories.

*Private and Individual ownership of systems*– The team visited locations where the PV systems are owned by private individuals. Typical examples are the individual houses in Sagar Island village and Patna.

*Privately owned systems by Institutions/Organizations*– This category includes private institutions like the Rajagiri Engineering College, Kochi and the Pune Royal County (builders). The installations in Auroville, Pondicherry has also been included in this category.

*Public Installations owned by user communities*– These are generally systems with a few kW capacity installed and operated by a group of individuals for a common use. The mini-grids of

Sunderbans, the community water pumping system in Patna and the community rooftop installations in Tilonia are examples.

*Public Installations by Government and Semi-government Institutions*– These include the installations at research centres, and those for demonstration purposes. Installation at renewable energy park, Kochi and the Indian astronomical observatory in Hanle and at various research centres are typical examples.

### 9.2.2. Categorization Based on Financial Models

There were basically 4 financial models found out in the different installation sites we have surveyed

*Self-financed systems without government incentives*– These are systems where individuals or communities have paid 100% of the initial investment as well as the maintenance charges.

*Self-financed with capital subsidy* – These are installations which have availed a capital subsidy (varying between 30 - 70%) from the central/state governments and are self-financing the maintenance charges.

*Government/ External funded capital and users bearing the Operation and Maintenance (O&M) charges* –Here the government (local or state) have given 100% investment of capital and they are trying for a cost recovery through monthly charges for the users.

*Government funded capital investment and O&M*–These are the cases where the local, state or central government has invested on PV modules mainly for promotion of technology and research, and is also bearing the O&M charges.

Table 9.1 shows the number of sites as differentiated in an ownership-financial model matrix based on the above classifications.

**Table 9.1 Ownership - finance model matrix**

	<b>Self-financed systems without government subsidy</b>	<b>Self-financed with capital subsidy</b>	<b>Government/ External funded capital and Users bearing the O&amp;M charges</b>	<b>Government funded capital investment and O&amp;M</b>
<b>Private (Individual)</b>	6	1		
<b>Private (Institution)</b>	2	3		
<b>Public (Community owned)</b>	2		2	
<b>Public(Government Institution)</b>				6

### 9.2.3. Categorization Based on End Purpose of Installation

The basic motivation or end purpose for the installation of the surveyed PV systems were analysed and categorised as below.

*Necessity* – These are installations which are absolutely necessary in their given context. The proper functioning of the system is essential for meeting some urgent needs of the installer, eg. The roof top SHS installations at Tilonia, and the installation in Hanle.

*Optional power/Back up*– These are installations where the installer has an alternate option for power. PV is a backup option to meet emergency situations, e.g., rooftop PV installations at Patna where grid extension had taken place.

*Income generation/Savings* – There are installations where the major driving force was the income generation (like agriculture) or saving money on electricity bills or diesel, eg. installations for public space lighting in the housing society at Pune.

*Promotion of Green Energy*– Here the basic motivation for installing a PV system was to promote green energy. There are non-governmental organisations (like in Auroville) as well as government organisations (Renewable Energy Park) which have installed PV systems for this reason.

*Research*– These are installations meant only for research activities, e.g., Installations at SEC, Tata BP, IIT Madras etc.

Table 9.2 shows the ownership-end purpose matrix.

**Table 9.2 Ownership – End purpose matrix**

	Necessity	Optional power/ Backup	Income generation/Savings	Promotion of green energy	Research
Private (Individual)	5	1		1	
Private (Institution)			2	3	
Public (Community owned)	3		1		
Public (Government Institution)	1		1	2	2

### 9.3. Parameters for Analyzing Appropriateness in Installation: Location and Accessibility, Support Structure, Shading, Tilt angle and Orientation

The parameters for analysing the appropriateness in the installation of the modules are explained in this section. An analysis on the appropriateness based on the ownership of the systems is also performed.

*Accessibility*– Ease of access to the modules is important since it affects the regular maintenance activities. The access was defined as easy or difficult, and the distribution (with ownership as parameter) is shown in Fig. 9.1.

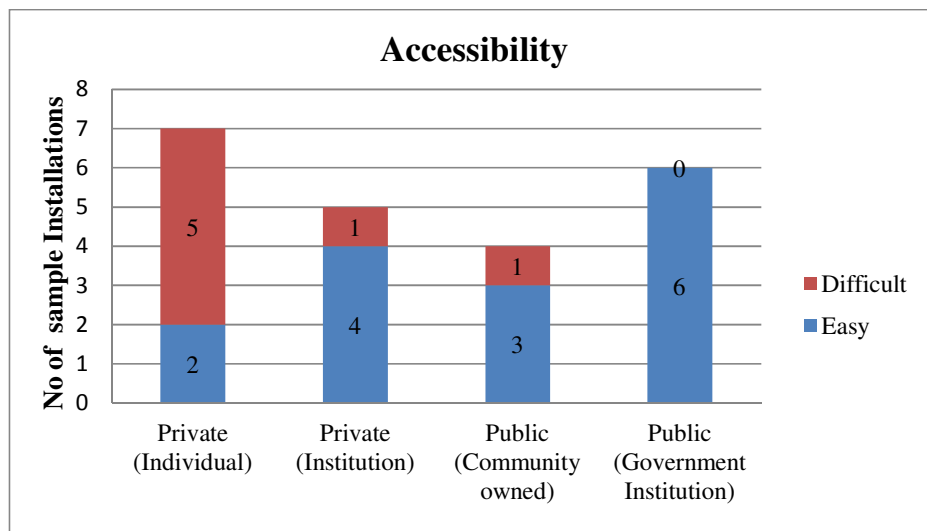

Fig. 9.1: Ease in accessing the module installation location

It was noted that most of the privately owned installations by individuals, which are basically households, have difficulty in accessing the rooftops where they have installed the modules. Only 2 out of the 7 sample locations have easy access to PV modules, because they were either mounted on the ground or had a convenient means to access rooftops. One out of 5 installations in private institutions covered in the survey had this issue of accessibility. The publicly owned installations had good access, for example, all installations in the government institutions had easy access to the modules.

*Shading*– The extent of shading over the modules, not only at the time of installation, but also during its entire lifetime is important. During our survey, shading was found to be a factor which affects the degradation of modules. In some cases, the modules were initially installed in locations where there was no shading. Over time, trees have grown up and their shadows are now falling on the modules. A general picture on module shading can be understood from the chart in Fig. 9.2.

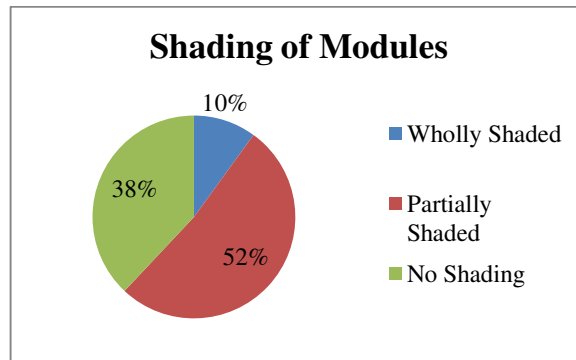

Fig. 9.2: Shading of Modules

Almost 62 percentage of the modules surveyed were shaded. The major shading objects were trees or buildings, as shown in Fig. 9.3.

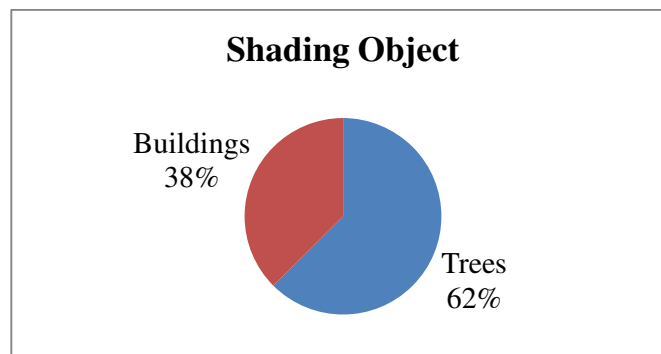

Fig. 9.3: Causes for shading of modules

Figure 9.4 shows the shading distribution for different as a function of ownership.

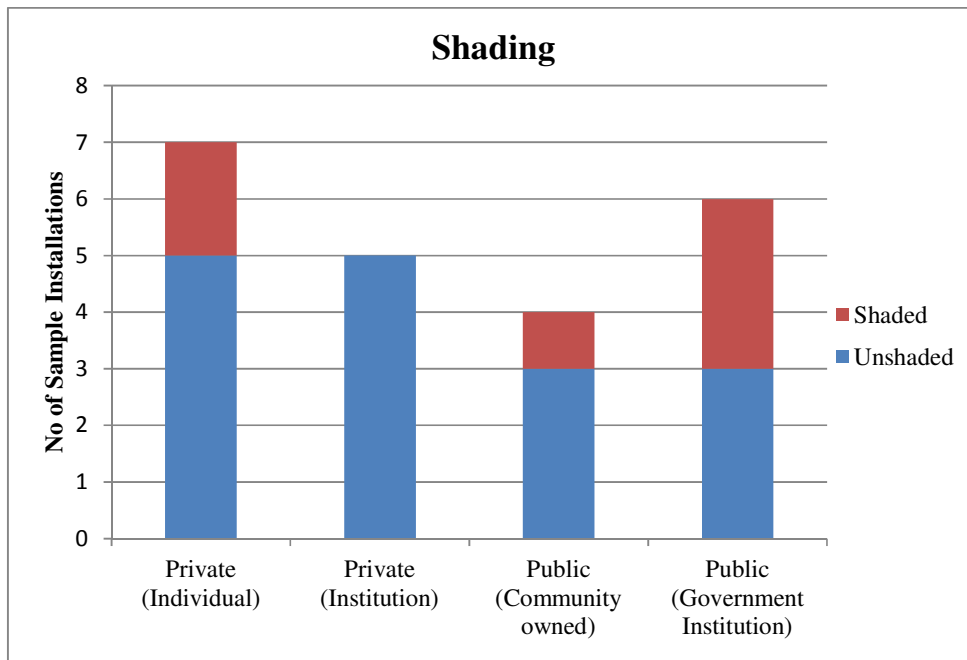

Fig. 9.4: Shading of PV modules based on ownership category

Shading is an issue with some of the individually owned smaller size systems (households), where in most of the cases, trees were the shading objects. Almost all the private institutions and community owned public installations had taken care in installing the modules in a shade free area. It was observed that 3 out of 6 installations over government institutions were shaded by either trees or nearby buildings.

It is known that partial shading of a module can cause local hot spots which can lead to long-term degradation. An analysis of the degradation rates of shaded and un-shaded modules covered in the survey was performed. In order to eliminate the spurious effect of very low degradation rates observed in Cold climate (Ladakh, where there is also very no shading), we have eliminated from our analysis all the modules from the Cold climate. As shown in Fig. 9.5, the shaded modules degrade almost three times faster than the unshaded modules (median value of annual degradation of shaded modules is 1.6% whereas the median value of degradation of un-shaded modules is just 0.56%). This interesting data is, as far as we know, the first field observation of the deleterious effect of partial shading on the long-term performance of modules. Figure 9.6 shows the  $P_{max}$  degradation rate with respect to the amount of module area under shade. It seems to imply that  $P_{max}$  degradation rate increases with increase in the amount of module area shaded. Literature shows that apart from the shaded area, the geometry of the shaded region also plays a role in deciding the effect of shading on the module performance. However, in our case, the geometry of shading was not recorded, so we are unable to assess its effect.

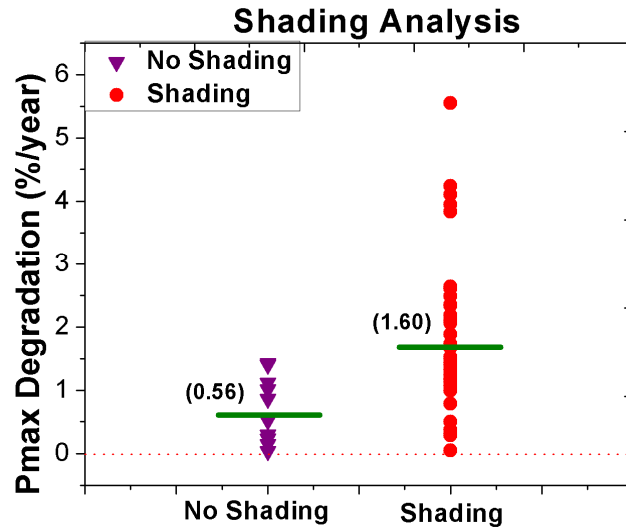

Fig. 9.5: Comparison of degradation rates of shaded and un-shaded modules

*Orientation and Tilt angle*– Based on the location and use of the installation, modules should be optimised in terms of direction and tilt angle (latitude degree). Almost all of the installations covered in the survey were properly oriented (south facing), whereas the tilt angle was very often not the correct one. Figure 9.6 shows the tilt angle used versus the latitude of the site.

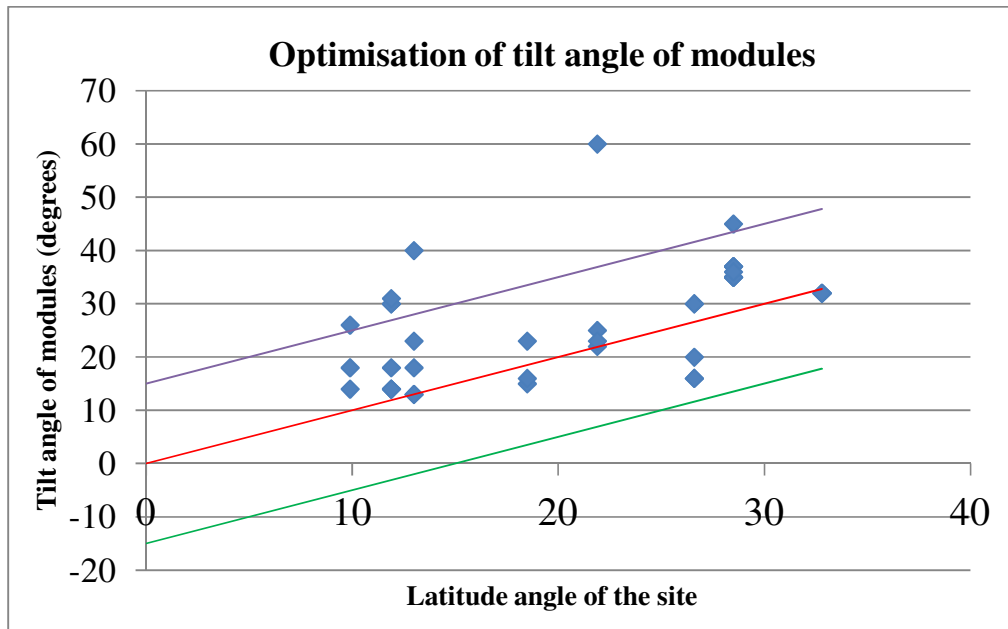

Fig. 9.6: Optimisation of tilt angle of the modules

If the modules were optimised for maximum annual yield, then the sample points should have followed the red line in the above picture (where tilt angle = latitude angle  $\pm 2^\circ$ ). If they were optimised for maximum yield in winter, then they should lie along the violet line (latitude +  $15^\circ$ ).

For maximum yield in summer months, the modules should have been aligned along the green line (latitude – 15°). 50% of the installations had their modules at an un-optimized tilt angle, which will reduce the annual PV generation. Figure 9.7 shows the histograms for tilt angle. Two out of the 7 installations covered in the individually owned systems were having manual tracking facility and were optimised for maximum yield. The rest of them were just installed at the angle of the rooftop itself. Two out of 5 private institutions have installed the modules at an angle of 10 to 18 degrees more than the required angle. In case of the community owned public installations, the error in angle for the incorrectly oriented modules varied from -6 to -10 degrees. In government institutions, where the module tilts were not optimised, the deviation in angle varied from +10 to +15 degrees from the optimum angle required.

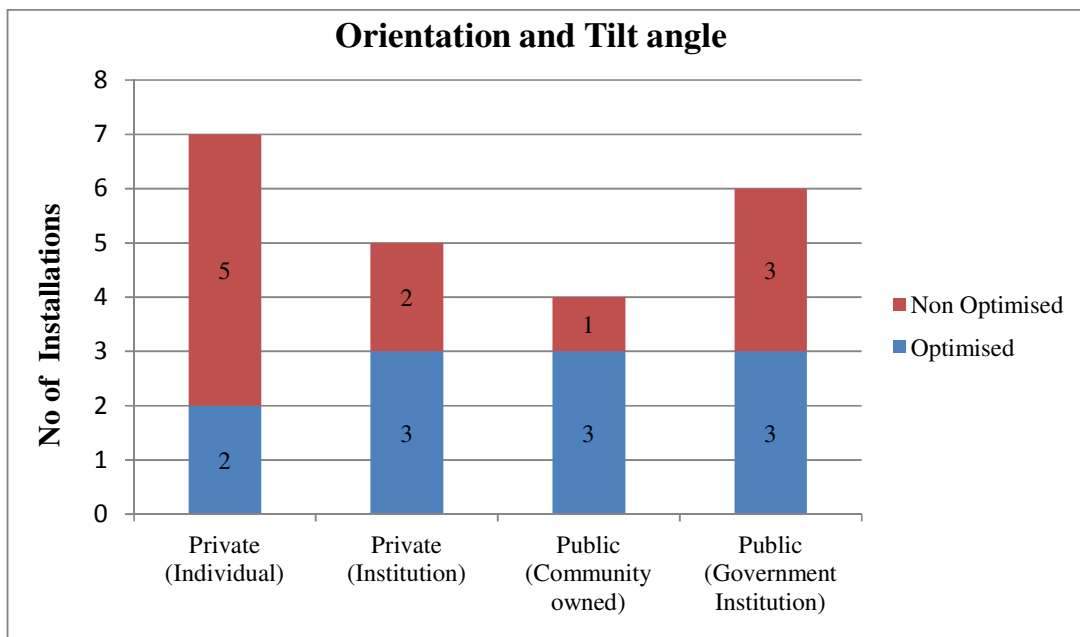

Fig. 9.7: Optimisation of tilt angle and orientation

*Support structure* – The modules should be placed on a proper support structure (strong and durable). It is also important to have air flow at the back of the modules in case of rooftop installations. Figure 9.8 shows the histograms for support structure.

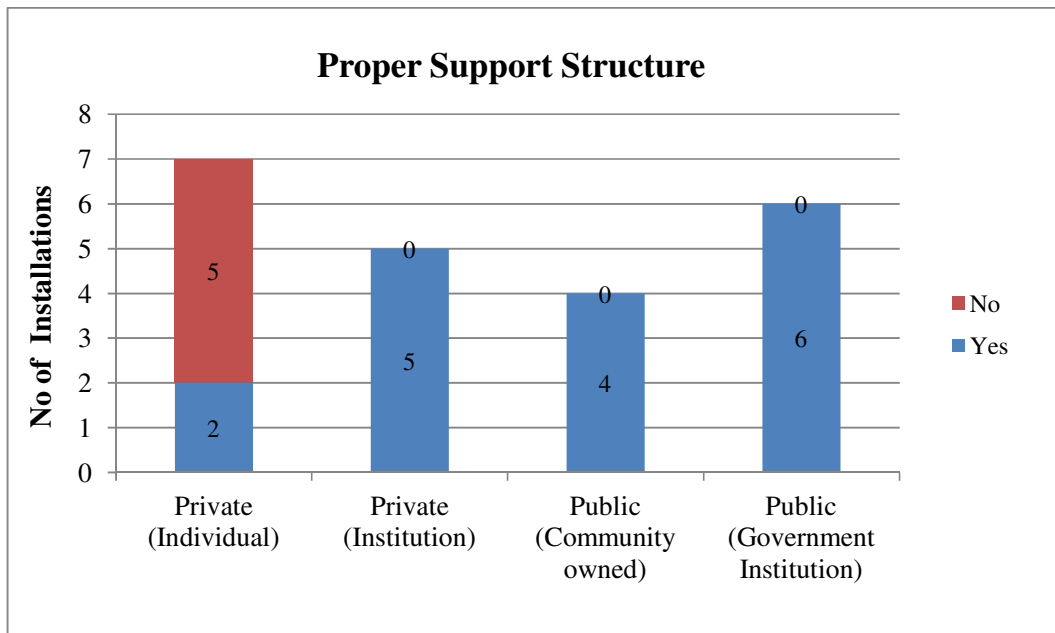

Fig. 9.8: Provision for proper support structure for modules

The additional cost on support structures has kept the household-level individual installations from adopting proper support structures for the panels. It was observed that in some cases the PV modules were just laying on top of the thatched roof tops without adequate air flow on the back of it. All the other ownership types had proper support structures.

An attempt was made to quantify the overall appropriateness of installation by assigning values (1 or 0) to the different parameters discussed above. The scheme for assigning values is given below.

Parameter	Points associated with the parameter
Modules are installed in a shade free location	Yes = 1 No = 0
Modules are easily accessible for cleaning	Yes = 1 No = 0
Modules are properly oriented and optimised for maximum yield	Yes = 1 No = 0
Modules are properly mounted on a support structure	Yes = 1 No = 0

If all the observations are favourable, then the PV system gets maximum points (4). Figure 9.9 shows the histogram of the points obtained as a function of ownership type (we have shown the maximum, minimum as well as average points obtained). The analysis reveals that there are individually owned installations with all parameters being inappropriate (minimum score = 0), i.e. the modules are shaded, not properly mounted or oriented, and have difficulty to access and clean. The average score is the highest for government institutions, and the maximum score also for this type is 4. This is an expected result, since many of them were research centres. Another interesting finding was that the community owned public installations are having higher average score than installations owned by private institutions.

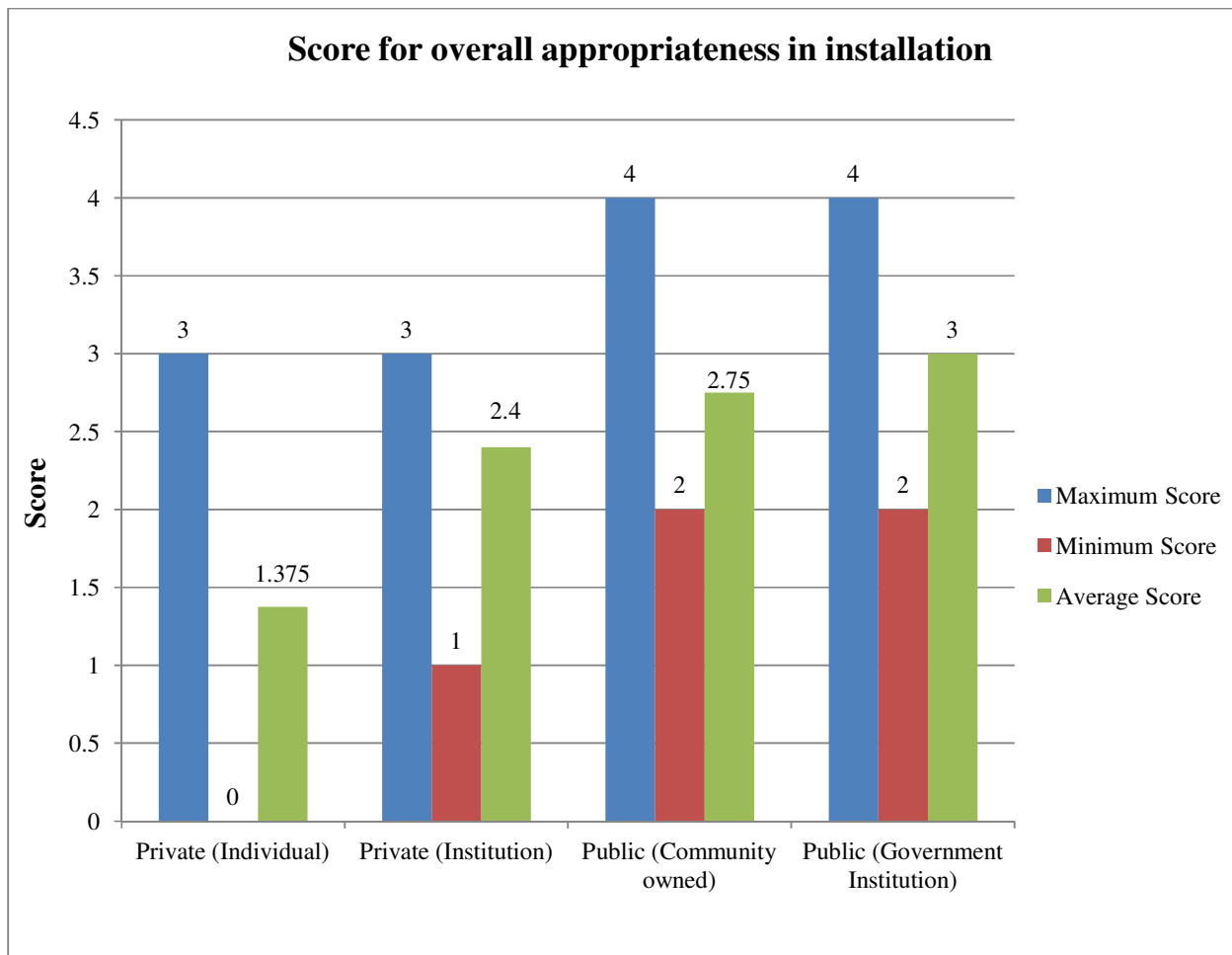

Fig. 9.9: Comparison of scores for appropriateness of PV installations categorised based on ownership

#### 9.4. Parameters for Analyzing Appropriateness of System Maintenance: Module Cleaning, System Maintenance and Skill Level of Technicians

In the last section, we looked at the aspects related to the installation of the PV modules. In this Section, we look at the aspects related to system maintenance, viz. module cleaning, maintenance and skill level of technicians.

*Module cleaning cycle* – The frequency of cleaning of the modules was analysed. This is shown in Fig 9.10. It is pretty clear that the individually owned household installations on the rooftop are cleaned less frequently. There were some modules which were never cleaned, or the users were not aware of the necessity of cleaning. Private institutions and community based institutions clean their modules more regularly than individual owners. The lower frequency of module cleaning in individual installations can be correlated with the difficulty of access as observed in the previous section, or ignorance about the necessity of cleaning the modules. The three installations in the government institutions which are not frequently cleaned (all of which are easily accessible as observed in the previous section) show clear negligence. The effect of soiling on  $P_{max}$  degradation rate can be seen in Fig. 9.11. We find that Power degradation (%/year) for heavily soiled modules is higher than for lightly soiled modules. In the figure, the numbers in bracket above the green crossbars indicate median values of  $P_{max}$  degradation rate. A possible reason can be that the soil deposit on top of the module is cutting off the amount of sunlight reaching the solar cells beneath, but the dust layer is itself getting heated up by absorbing sunlight. Since the module is getting lesser light and its output power (converted electrical power exported out of the module) is reducing significantly. The effective input energy to the soiled module (= incident solar radiation – reflected radiation due to dust cover) also reduces but not to that extent as the reduction in the output power of soiled module. The difference between the effective input power and output power is dissipated by the PV module as heat. This difference is higher for the soiled modules as compared to the cleaned modules. So, the soiled modules operate at higher temperature than the clean modules. This can also be observed by taking the IR images of soiled and cleaned modules. Figure 9.12 and 9.13 shows the visual and its corresponding IR image of the modules. The IR images shown on the left hand side of the figures are colour coded where the temperature scale is shown by the colour bar. The colour near the blue region indicates a lower operating temperature whereas higher operating temperature is shown by the red colour. It can be clearly noticed from the figures that the cleaned modules are operating at lower temperature (shown by blue colour in the IR image) as compared to the soiled modules (shown by orange colour in IR image). Operation at

higher temperatures will induce faster degradation in the module components, and hence we are seeing higher power degradation for higher degree of soiling. The correlation between the cleaning interval and  $P_{max}$  degradation rate can be seen in Fig. 9.14. It can be seen that the  $P_{max}$  degradation (%/year) increases on increasing the interval between successive cleaning of modules. This trend also supports our finding that soiling is causing faster degradation of  $P_{max}$ .

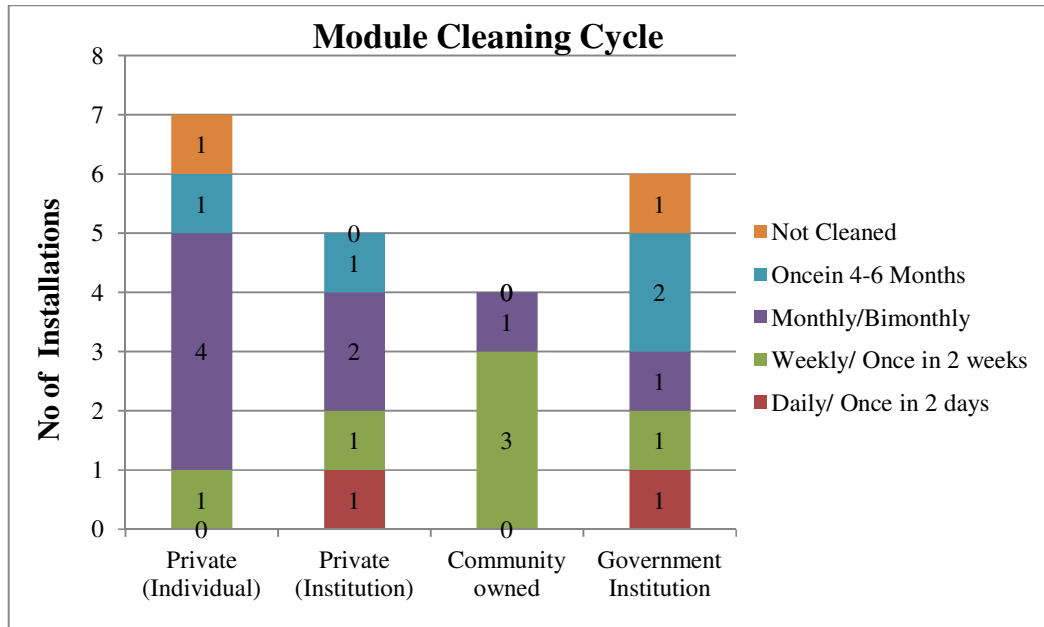

Fig. 9.10: Comparison of cleaning cycles of PV installations categorized based on ownership

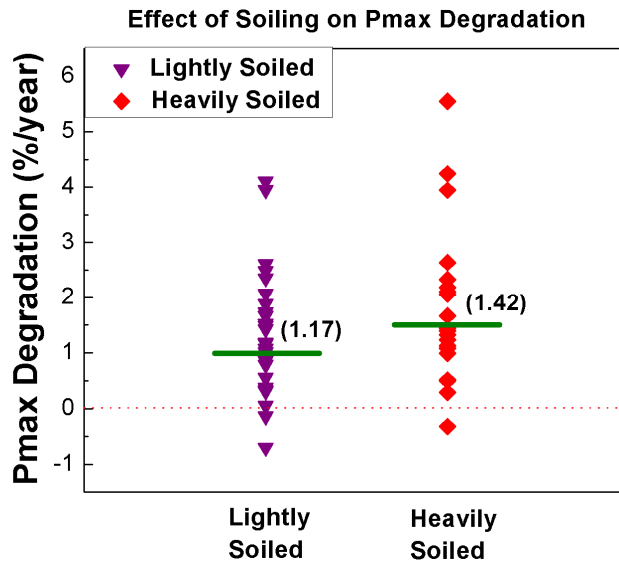

Fig. 9.11: Effect of soiling on  $P_{max}$  degradation

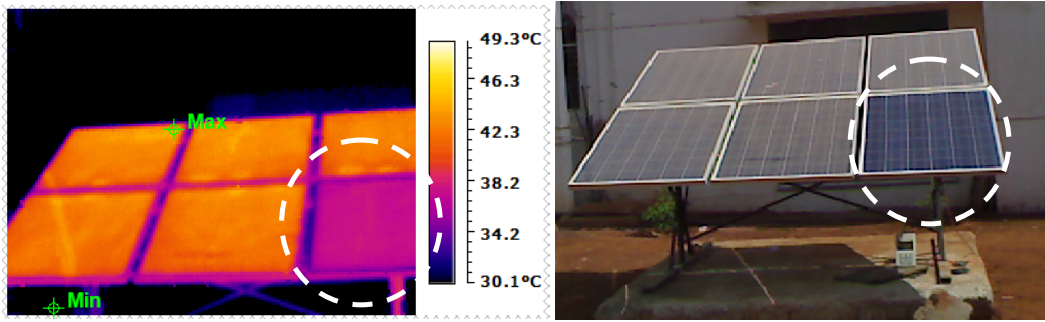

Fig. 9.12: Infra-red Image of a set of soiled and cleaned modules.

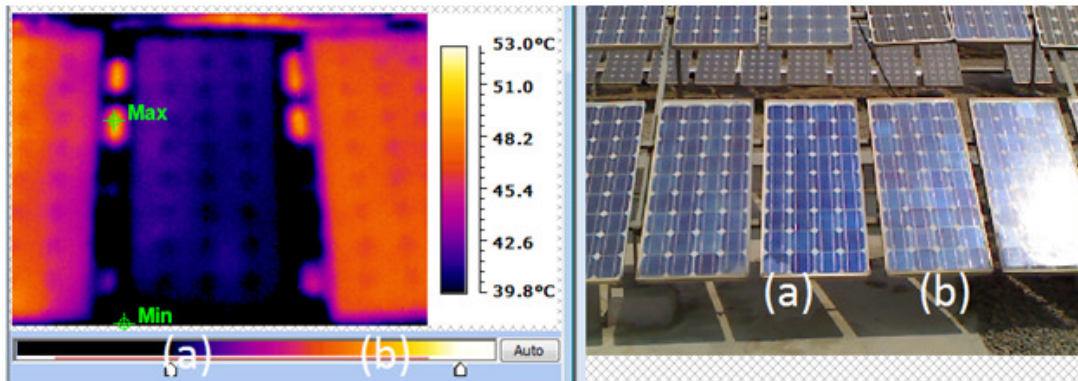

Fig. 9.13: Infra-red Image (a) cleaned module and (b) soiled module

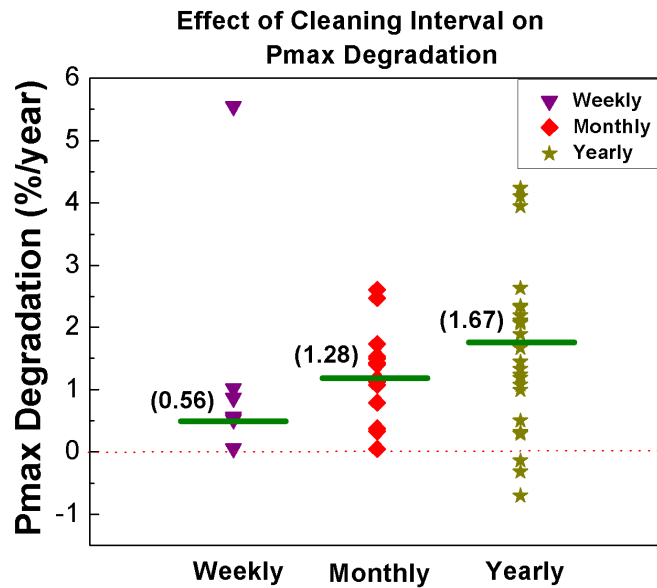

Fig. 9.14: Effect of cleaning interval on  $P_{max}$  degradation

*Nature of Maintenance* – The maintenance can be of two types, responsive and preventive. Most of the individual owned PV systems are maintained responsively. i.e., whenever they face some

problem in its functioning. Comparison of the type of maintenance by different PV system owner categories is shown in Fig. 9.15. Once again, publicly owned community based installations are all well maintained in a preventive way, so as to avoid any malfunctioning. Half of the installations on the government institutions are maintained responsively and 4 out of 5 installations by private institutions are responsively maintained. The effect of type of maintenance (preventive/responsive) can be seen in Fig. 9.16. The  $P_{max}$  degradation is more if responsive maintenance is performed (after critical failures) as compared to preventive maintenance (periodic).

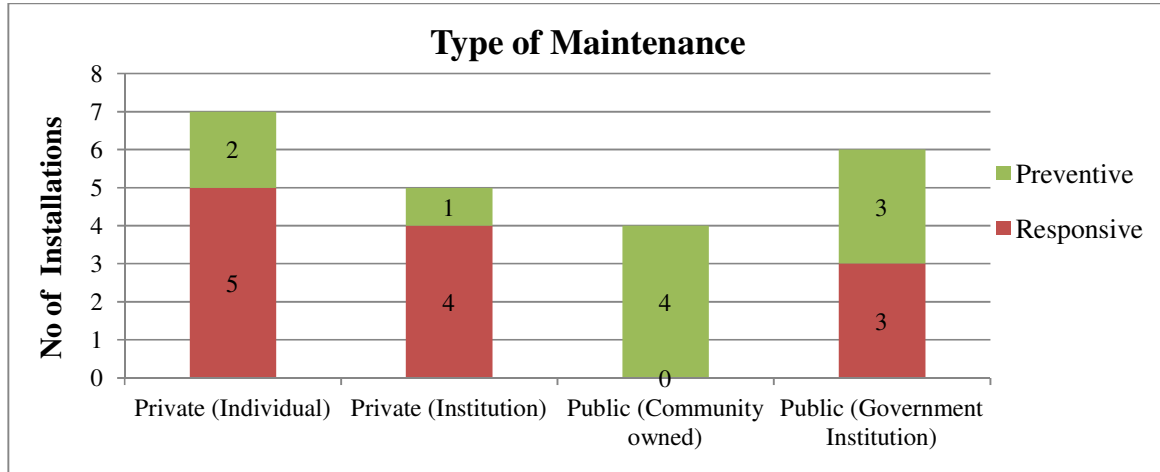

Fig. 9.15: Comparison of the type of maintenance by different PV system owner categories

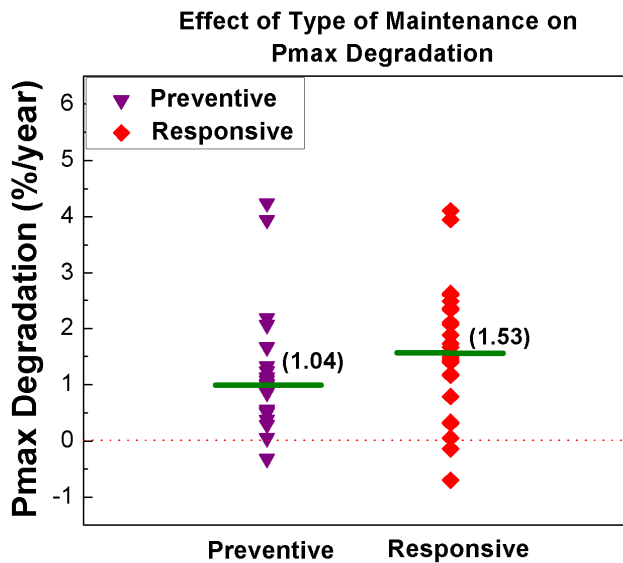

Fig. 9.16: Effect of type of Maintenance on  $P_{max}$  degradation rate

*Maintenance Cycle Duration* – The analysis in the previous section shows that most of the individual households, private institutions and half the government institutions perform the system maintenance activities in a responsive manner. They do the routine check-ups on the condition of batteries,

connections in the junction boxes, charge controllers etc. less frequently or only when they face a system failure. A further detailed analysis revealed that most of the individually owned installations have to avail the service of a technician once in a year to keep the system running, i.e. they face system failures at least once in a year. Most of the private institutions have half yearly or annual maintenance contract with the system installers. The private institution that performs maintenance activities preventively has monthly check-ups of the systems. Rest of them avails the service of a technician once or twice in a year. Figure 9.17 shows that community owned installations mostly have preventive monthly system check-ups and testing. There are a few installations on government institutions which are purely responsively maintained. Whereas there are also good examples for regular maintenance activities done in three of the six installations on government institutions. However, the interval between health checkups of the system (preventive maintenance) need not be smaller than a year. The correlation between the maintenance and  $P_{max}$  degradation can be observed in Fig. 9.18. The median  $P_{max}$  degradation rates do not follow any particular trend.

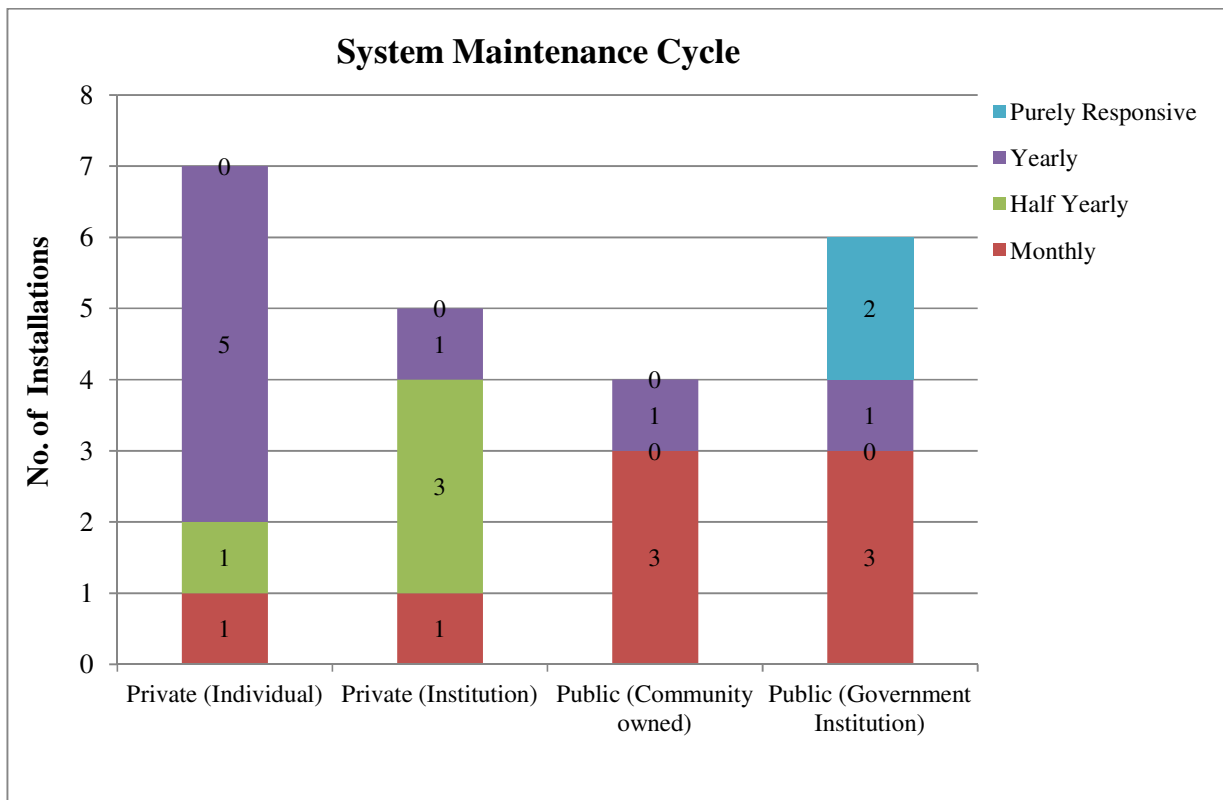

Fig. 9.17: Comparison of the time duration between two successive maintenance services among different ownership categories

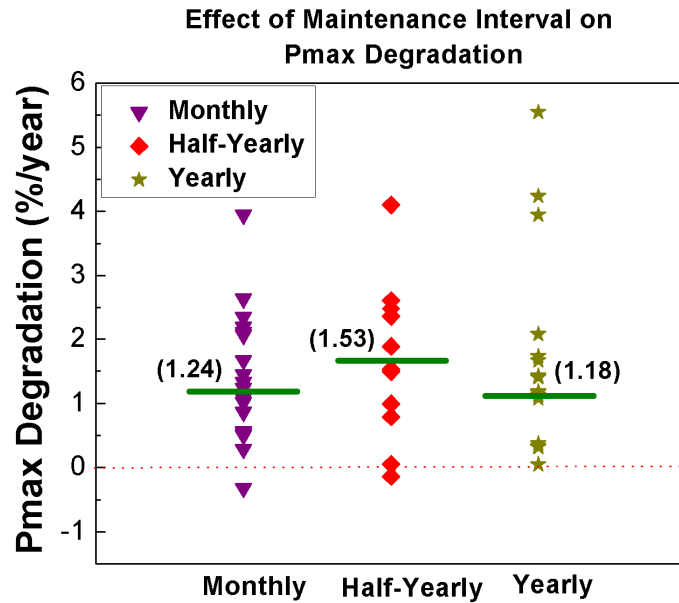

Fig. 9.18: Effect of Maintenance Interval on  $P_{max}$  degradation rate

*Skill level of Technicians* – After interacting with the technician(s) who handle the routine check-ups on the installations, we have categorised them into three skill levels. Those people who have knowledge on how to regularly clean the modules, check and maintain the water levels of the batteries, check for corrosion in junction boxes, and check for tightness of connections have been categorised as people with basic training on system maintenance (people with know-how to prevent and detect any degradation). Those people who can also actually do the repair work of BOS components are considered as people with good maintenance skills. Those people with good exposure to the PV installation and maintenance are considered as experts (these are often EPC company representatives).

The results of the assessment are shown in Fig. 9.19. It was observed that individual system owners mostly depend upon local electricians with comparatively good maintenance skills to repair their PV systems. Three out of the 5 private institutions have depended upon experts for system maintenance. Community owned systems are also maintained by people with good skills in maintenance.

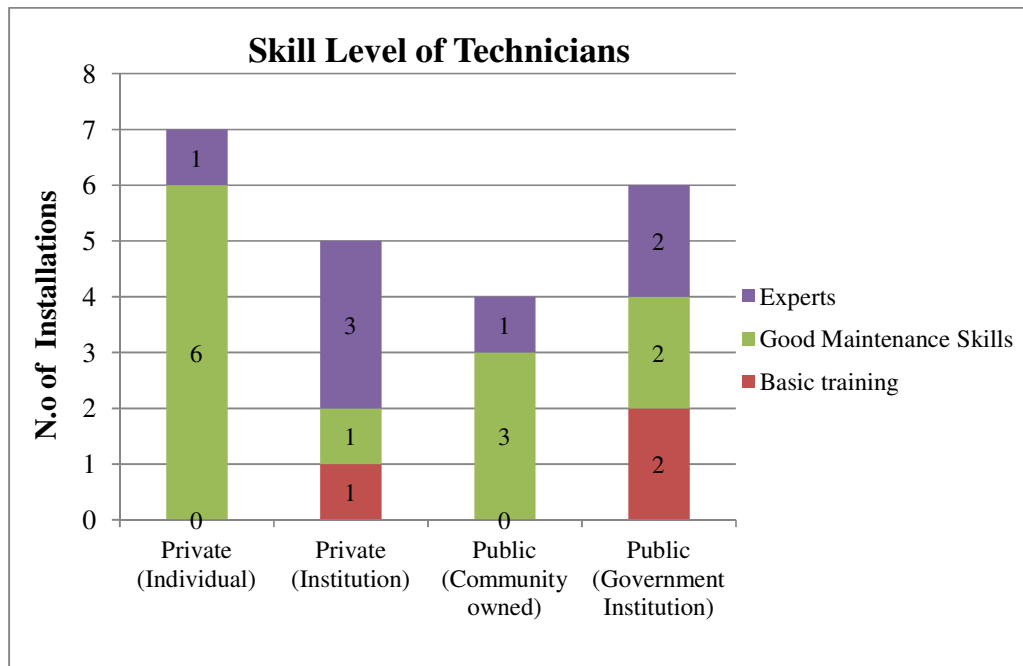

Fig. 9.19: Comparison of the skill level of technicians doing the maintenance activities of systems of different ownership categories

## 9.5. Linkages between Ownership, Financial Model and Purpose of the Installation with Appropriateness in Installation and Maintenance of the Systems

### *Private installations with Individual ownership:*

- Most of the installations in this category were self-financed without capital subsidy and were absolute necessities. This shows that people are willing to pay to meet their needs if PV is a good solution. But in most of the cases, the appropriateness in installation is quite poor (lack of awareness and knowledge).

### *Private institutions:*

- Those institutions with the basic driving force as savings/income generation have invested in PV even in the absence of capital subsidy from the government. They seem to be properly maintaining and operating the installations.

- Those institutions with the motive to promote green energy has availed capital subsidy from the government. But out of the 3 such instances, only 2 seem to be truly supporting their cause.
- The private institution which has installed the PV modules for research has completely neglected the modules once the research has been completed.

*Community based Public installations:*

- The community based PV installations seems to be more effective than individually owned installations in areas where they are a necessity. We found examples where there are community based and individual PV installations which are completely self-financed and necessary, where community based ownership models are better maintained than individually owned installations and private institutions.
- Capital investment and cost recovery model by government institutions are found effective in small-scale community based models, where there the installations are absolute necessities or if it generates income. Such installations seem to be properly maintained.

*Installations on Public/Government Institutions:*

- In places where the investment is completely made by the government and the requirement is absolutely necessary, the PV systems have been maintained properly. Same is the case if there is a cost recovery model by the government institution.
- Those installations which were meant to promote the technology through public demonstration, which are completely funded and maintained by the government, seem to be failing to meet the purpose, since the analysis results shows that the two installations coming under this category are not installed appropriately, and not maintained well.
- Investment in research centres seems to be justifiable since the modules are properly maintained in most of the cases.

## **9.6. Conclusions**

During our survey, based on observations as well as interrogation, we could record some non-technical socio-economic aspects related to PV system installation and maintenance. It was seen that whenever there are incentives to the installations in terms of savings or income generation, the maintenance activities are properly done, irrespective of the type of ownership of the system. Private

institutions saving electricity bills and farmer community generating additional income through PV water pumps have maintained the installations properly. Government Agricultural institute saving diesel for water pumps is also maintaining the system well. At locations where there are no better options than PV, capital investment by the government can be justified and was found recoverable. The PV micro-grid based power distribution system has worked well in Sagar Island for more than past 20 years. Community owned PV installations are found to be more effective than individual systems if there is a proper institutional set up for operation and maintenance. This was mainly because of the presence of institutional mechanisms for operation and maintenance.

The learning from the analysis indicates that the proper installation and maintenance and hence the performance degradation of a PV system is also a function of the ownership, financial model and the true purpose of the installation. Hence whenever there is policy driven approaches for promoting PV, the socio economic aspects of the installations also need to be considered. While designing schemes for promoting PV, preferences should be given for applications which are absolutely necessary and which have regular cash flow linkages based on its performance (savings, income generation or cost recovery through monthly service charges). Regular maintenance activities should be institutionalized and the responsibility for ensuring the maintenance should be preferably vested on a 'public' entity, which may be a user co-operative or maintenance committee etc.



## 10. Future Work

---

The present survey has been conducted on a limited number of old PV modules (not connected to the grid), which are visibly degraded, and situated in a variety of climatic conditions in India. The data is very useful, and gives an indication of the types and amount of degradation which have been seen in the field. As described in Chapters 7, 8 and 9, the degradation in performance has been related to the type of technology, the climatic zone, the visible signs of degradation, and various social, financial and cultural parameters.

It will be very desirable to do a follow-up survey every year for a few years, so as to check the performance of the same modules, and thus determine the year-on-year degradation. In future surveys, some of the limitations of the present can also be addressed. These limitations include: (a) the relatively small number of samples surveyed, (b) uneven number of samples in the climatic zones, (c) uneven distribution in terms of module technology. In particular, it would be desirable to have more data in the Temperate and Cold climatic zones, and perhaps even in the Hot & Dry zone, given that most new installations are coming up in this zone. Furthermore, most of the data are available for crystalline silicon (which is understandable, as this was the dominant technology 5-15 years ago), and a specific attempt should be made to locate some thin film modules which have been in the field for a few years.

Furthermore, during the analysis phase of this work, we felt that it would have been very desirable to have some more data, and some of these are listed below.

- i) Temperature coefficient of the modules should be measured in the field, as this would allow better extrapolation to STC. This can be done by first cooling the module by pouring water on top and then recording the I-V as the module slowly heats up, using the automatic I-V tracer.
- ii) IR images of all modules should be taken to identify modules having hotspots, which will be useful for correlating to degradation. Also, this will guide us with regard to proper positioning of the module temperature sensor.
- iii) The health of the bypass diodes should be checked by using the Cell Line Checker.
- iv) In the present survey, we have considered the area of shading on the modules by visual estimation. If available, a shading indicating equipment (Sun-eye) should be used to quantify the shaded area in the future surveys.

## ALL INDIA SURVEY OF PV MODULE DEGRADATION: 2013

- v) We would like to use a colour sensitive instrument to quantify the extent of brown discoloration in the PV modules. Quantification of the discoloration will help us formulate a better model for the same.
- vi) The battery and inverter parameters should be noted in greater detail for aiding in calculation of the efficiency of the system.
- vii) We should select modules from both ends of the string and also a few from the middle of the string in order to study the effect of biasing on module degradation.
- viii) In order to model the effect of corrosion on the Fill Factor, modules with different levels of (visible) corrosion should be inspected.
- ix) For all the modules, we should take the IR image and I-V data (before and after cleaning the module) so that we can analyze the effect of soiling in greater depth.
- x) In order to assist in better understanding of the observations of the field surveys, additional laboratory based tests will be required. These may include, for example,
  - testing with different soil dusts,
  - changes in the short circuit current and the corresponding changes in spectral response/ quantum efficiency at cell/ module level with decoloration/ dust etc,
  - degradation in loaded versus unloaded modules
  - potential induced degradation
  - shading related issues
  - experiments to understand the reasons behind the improvements in open circuit voltage reported in the field-aged modules.

We intend to use these pointers in the follow-up survey planned for the summer of 2014.

# 11. Conclusions & Recommendations

---

## 11.1 Overall summary

An All-India survey of PV modules was undertaken during the summer of 2013 by the National Centre for Photovoltaic Research and Education (NCPRE) together with Solar Energy Centre (SEC). The modules were typically between 5 to 20 years old, and emphasis was given to modules which showed visible signs of degradation, with the intention of understanding degradation mechanisms. All modules were in stand-alone off-grid configurations. A total of 63 modules spanning 26 sites located in 5 climatic zones of India were surveyed.

The data collected during the survey included a visual assessment using a standard checklist, I-V data, ambient and module temperatures, radiation level, some “socio-economic” details, and in some cases, IR images. This is described in Chapter 3.

The data collected at prevailing field temperature and radiation conditions were converted to standard test conditions (STC) of 25 °C and 1000 W/m<sup>2</sup>. The procedures used for this conversion (and tests to assess their accuracy) are described in Chapter 5. Based on this extrapolation, the current performance of the modules was found, and using the name-plate data, the extent of degradation in performance was calculated. It has been emphasized earlier, and bears repetition here, that the main aim of the survey being to understand degradation mechanisms, we had mainly looked at visibly-degraded modules; and hence the average annual degradation rates for various parameters were naturally higher than typical values reported in the literature.

Since we had a reasonable amount of data on a fairly large sample size, we could do a statistical analysis of the data. The data were analysed in terms of the electrical performance and degradation, the visual appearance and degradation, and the socio-economic factors related to their installation and operation. These are described respectively in Chapters 7, 8 and 9. Furthermore, we have attempted to correlate the electrical performance to signs of visual degradation, as well as the socio-economic factors.

## 11.2 Key Observations and Conclusions

This analysis of Chapters 7, 8 and 9 threw up some interesting observations and conclusions, which are listed below. Many of the results were expected; however, there are also some unexpected results.

From the **electrical performance analysis**, we saw that

- Mono-crystalline silicon performs slightly better than multi-crystalline silicon, but the difference is not significant.
- Power degradation for c-Si in the hot zones (Hot & Dry as well as Hot & Humid) is significantly higher than in the other climatic zones (Temperate, Composite and Cold).
- Hot & Dry shows more degradation in power than Hot and Humid, which is surprising.
- Across climatic zones, the major causes for power degradation for c-Si are a reduction in short-circuit current, followed by a reduction in fill factor.
- In Hot & Dry zone, reduction in short-circuit current dominates, while in Hot & Humid zone, the reduction in fill factor also contributes significantly (in Hot & Humid condition, there is contact degradation, which leads to an increase in series resistance and hence in Fill Factor).
- For thin film PV, a reduction in fill factor is the major cause for degradation in power, though the data are rather sparse to draw a reliable conclusion in this regard.
- In some rare cases, it has been found that some modules are delivering close to their rated power, even after decades of service in field. Such Champion Modules give us hope that very soon we shall have modules that come with 35 years warranty.

From the **visual degradation analysis**, we saw that

- Discoloration of encapsulant is the most widely observed degradation, followed by corrosion of metallization, interconnects and output terminals.
- Discoloration is most prevalent in the Hot & Dry climatic zone, since discoloration is accelerated by high temperatures
- Discoloration is not very prevalent in the Cold & Dry climate of Hanle, despite the higher amount of UV radiation at 4,500 m altitude.
- Delamination is seen in older (> 10 year old) modules, irrespective of climatic condition.
- Corrosion of metallization, interconnects and output terminals is seen predominantly in Hot & Humid zone, and this is not unexpected.

- Amount of discoloration of encapsulant is directly co-related with reduction in short-circuit current (as expected), leading to loss of power.
- Corrosion is co-related with increase of series resistance, and thereby reduction of fill factor, leading to loss of power.
- Delamination results in higher operating temperature of the module which can lead to faster degradation.

From the **socio-economic analysis**, we saw that

- Publicly owned (by communities or government) PV systems were better installed than privately owned ones.
- Private institutions and community owners have better cleaning cycles than either individual private owners or government.
- Publicly owned PV systems were generally better maintained, with preventive maintenance cycles, instead of just responsive repair.
- Performance of modules in situations where there was a savings or earning through power generation was generally good.
- Co-relation of shadowing with performance shows that there is significant long-term degradation in partially shadowed modules, probably due to hot spots created by shadowing.
- Co-relation of cleaning cycle with performance shows that there is a long-term degradation of modules which are not frequently cleaned, probably because modules with accumulated dust run hotter.
- Co-relation of maintenance cycle with performance shows that modules with regular preventive maintenance show less long-term degradation.

### 11.3 Surprise Findings

Some of the findings were unexpected. These “surprise findings”, are given below:

- The open circuit voltage of some of the PV modules has been found to *increase* slightly (instead of degrading) with time.
- The performance of a module with shattered front glass cover has been found to be higher than similar modules at the same site. The reason may be that the photo-oxidative bleaching of the discoloured EVA improves transmission of light and hence performance. Of course, the shattered glass also presents safety risks and allows water to flow into the modules, which will corrode the fingers and bus bars in the long run. This hints that development of encapsulants

which are permeable to oxygen (while impermeable to moisture whose ingress may cause corrosion problem) may improve the durability of the modules.

- At a site in Ladakh, we found that all installed modules of a particular manufacturer had discoloured while those of another manufacturer still retained the original appearance, in spite of being in the field for 15 years. This latter set of modules has been found to perform very well, and the average rate of degradation has been calculated to be about 0.12% per year. We classify these modules as *Champion Modules*, and we are attempting to understand the reasons for this.

## 11.4 Recommendations

Based on the results and analysis, some general **recommendations** which can be made are as follows:

- For modules to be deployed in the Hot & Dry climatic zone, encapsulant browning is the most serious long-term degradation mechanism, leading to a loss of power. The encapsulant characteristics of these modules should be critically analyzed, and appropriate accelerated tests on the encapsulant should be conducted before deployment in this climatic zone. In particular, if EVA is used as encapsulant, the formulation should include appropriate additives and UV stabilizers (as per guidance provided in [28]) and cerium oxide containing glass should be used as top cover, which would reduce the rate of discoloration, and improve long term performance.
- For modules to be deployed in the Hot & Humid climatic zone, corrosion is the main concern, followed by encapsulant browning. Due attention should be given to properly sealed junction boxes, and good electrical contacts (in addition to EVA as above) for modules to be deployed in this zone.
- Module degradation is minimal in the Cold & Dry climatic zone of Ladakh. This, coupled with the high radiation (can be in excess of  $1200 \text{ W/m}^2$  during summer), and generally cloudless skies, makes Ladakh an excellent place for solar energy generation, especially if the proposed 220 KV line connecting to the Indian grid [63] come through.
- For stand-alone PV systems, performance can be significantly improved by proper installation, and regular cleaning and maintenance cycles. These are not happening as well as they should due to lack of availability of trained manpower. Technician training is a key to wider and better use of stand-alone and small grid-connected systems.
- The survey should be repeated in 2014 and 2015 to track the further degradation of the modules in the 2013 survey. The future surveys should also locate and assess more modules in the temperate and composite climatic zones, where the numbers in the 2013 survey were too small to

## ALL INDIA SURVEY OF PV MODULE DEGRADATION: 2013

draw statistically meaningful conclusions. Further, since most of the PV modules surveyed were quite old, they mainly belonged to the crystalline silicon category (mono- and multi-). Special efforts should be made in the 2014 and 2015 surveys to locate thin film modules.

- All the modules surveyed were off-grid (since the survey focussed on old installations). A separate survey should be taken up for the large grid-connected PV installations that have come up during the last 5 years, as this would give major leads into appropriate technologies and climatic zones for JNNSM.



## References

---

- [1] National Building Code of India 2005, SP 7:2005, Bureau of Indian Standards, New Delhi, 2005.
- [2] “State-wise Solar Installed Capacity break-up”, [Online], Available: [www.mnre.gov.in/file-manager/UserFiles/SolarRPO/State-wisesolarinstalledcapacitybreak-up.xlsx](http://www.mnre.gov.in/file-manager/UserFiles/SolarRPO/State-wisesolarinstalledcapacitybreak-up.xlsx), [Accessed on 20th September, 2013].
- [3] M. A. Green, “Silicon Photovoltaic Modules : A Brief History of the First 50 Years”, in *Progress in Photovoltaics: Research and Applications*, vol. 13, issue 5, pp. 447-455, 2005.
- [4] C. E. Packard, J. H. Wohlgemuth and Sarah R. Kurtz, “Development of a visual inspection data collection tool for evaluation of fielded PV Module condition”, National Renewable Energy Laboratory, Tech. Rep. NREL/TP-5200-56154, 2012.
- [5] Kazuhiko Kato, “PV Module Failures Observed in the Field – Solder bond and bypass diode failures”, in *Proceedings of the Photovoltaic Module Reliability Workshop*, Golden, Colorado, USA, 2012. Available: [http://iea-pvps.org/index.php?id=223&eID=dam\\_frontend\\_push&docID=1275](http://iea-pvps.org/index.php?id=223&eID=dam_frontend_push&docID=1275). [Accessed March 14, 2014].
- [6] W. Herrmann, “Current-Voltage Translation Procedure for PV Generators in the German 1000 Roofs Programme” [online], Available: [http://www.f09.fh-koeln.de/imperia/md/content/personen/wiesner\\_wolfgang/veroeffentlichungen/26\\_proceed.pdf](http://www.f09.fh-koeln.de/imperia/md/content/personen/wiesner_wolfgang/veroeffentlichungen/26_proceed.pdf), [Accessed Feb. 20, 2014].
- [7] D. Dirnberger, J. Bartke, A. Steinhuser, K. Kiefer, F. Neuberger, “Uncertainty of Field I-V Curve Measurements in Large Scale PV Systems”, in *Proceedings of the 25<sup>th</sup> European Photovoltaic Solar Energy Conference and Exhibition*, 2010, pp. 4587-4594
- [8] Dirk C. Jordan, John H. Wohlgemuth, and Sarah R. Kurtz, “Technology and Climate Trends in PV Module Degradation”, in *Proceedings of the 27<sup>th</sup> European Photovoltaic Solar Energy Conference and Exhibition*, 2012, pp. 3118-3124.
- [9] John H. Wohlgemuth, O. S. Sastry, Adam Stokes, Yogesh Kumar Singh and Mithilesh Kumar, “Characterization of Field Exposed Thin Film Modules”, in *Proceedings of the 38<sup>th</sup> IEEE Photovoltaic Specialist Conference*, 2012, pp. 2411-2415.
- [10] O.S. Sastry, Sriparn Saurabh, S.K. Shil, P.C. Pant, Rajesh Kumar, Arun Kumar, Bibek Bandopadhyay, “Performance analysis of field exposed single crystalline silicon modules”, *Solar energy materials & Solar cells*, vol. 94, 2010, pp. 1463-1468.
- [11] O.S. Sastry, A. Anand, R.K. Singh, A. Kumar, Rajesh Kumar, Bibek Bandhopadhyay, “Performance comparison of three technology modules under similar outdoor conditions”, in *Proceedings of the 26<sup>th</sup> European Photovoltaic Solar Energy Conference*, 2011, pp. 3566-3568.

- [12] A. Sinha, O.S. Sastry, Y.K. Singh, M. Kumar, R. Gupta, "Performance of Champion's Module for PV Lighting Systems in India", *27th European Photovoltaic Solar Energy Conference*, 2012, pp. 3507 – 3510.
- [13] M. Va'zquez, & I. Rey-Stolle, "Photovoltaic Module Reliability Model Based on Field Degradation Studies", *Progress in Photovoltaics: Research and Applications* 16, 2008, pp. 419-433.
- [14] Tony Sample, "Failure modes and degradation rates from field-aged crystalline silicon modules", Presented at *Photovoltaic Module Reliability Workshop*, Golden, Colorado, USA, 2011. Available: [http://www1.eere.energy.gov/solar/pdfs/pvmrw2011\\_28\\_csi\\_sample.pdf](http://www1.eere.energy.gov/solar/pdfs/pvmrw2011_28_csi_sample.pdf). [Accessed March 14, 2014].
- [15] N. Bogdanski, W. Herrmann, F. Reil, M. Köhl, and K.A. Weiss, and M. Heck, "Results of a German Four-Year Joint Project Results of Three Years Module Weathering In Four Different Climates", in *Proceedings of the 25th European Photovoltaic Solar Energy Conference and Exhibition*, 2010, pp.4339-4343.
- [16] J.Campbell, Y.Zemen, B.Richardson, and B.Striner, "Photovoltaic Module Performance and Degradation as Compared in Distinct Climatic Regions". *38<sup>th</sup> IEEE Photovoltaic Specialist Conference*, 2011, pp. 1250-1255.
- [17] G.-H. Kang, K.-S. Kim, C.-H. Park, G.J. Yu, H. Ahn, D.Y. Han, "Analysisi of Durability of Field Aged Photovoltaic Modules", in *Proceedings of the 23rd European Photovoltaic Solar Energy Conference and Exhibition*, 2008, pp. 2822-2824.
- [18] M.A. Quintana, D.L. King, T.J.McMohan and C.R. Osterwald, "Commonly observed degradation in field-aged photovoltaic modules", in *Proceedings of the 29<sup>th</sup> IEEE Photovoltaic Specialist Conference*, 2002, pp. 1436-1439.
- [19] Chris Barry, "Why Glass Sometimes Breaks", Presented at *Photovoltaic Module Reliability Workshop 2011*, Golden, Colorado, USA, 2010. Available: [http://www1.eere.energy.gov/solar/pdfs/pvrw2010\\_barry.pdf](http://www1.eere.energy.gov/solar/pdfs/pvrw2010_barry.pdf) [Accessed March 14, 2014].
- [20] John Wohlgemuth, Daniel W. Cunningham, Andy Nguyen, George Kelly and Dinesh Amin, "Failure Modes of Crystalline Silicon Modules", Presented at *Photovoltaic Module Reliability Workshop*, Golden, Colorado, USA, 2010. Available: [http://www1.eere.energy.gov/solar/pdfs/pvrw2010\\_wohlgemuth\\_silicon.pdf](http://www1.eere.energy.gov/solar/pdfs/pvrw2010_wohlgemuth_silicon.pdf). [Accessed March 14, 2014].
- [21] Dr. Thomas Friesen, "Failures of Thin Film PV Modules: Field Experience", in *Proceedings of the Thin Film PV Reliability Workshop*, Golden, Colorado, USA, 2013. Available: [http://www.nrel.gov/ce/ipvmqa\\_task\\_force/pdfs/2013\\_thinilm\\_wkshp\\_friesen.pdf](http://www.nrel.gov/ce/ipvmqa_task_force/pdfs/2013_thinilm_wkshp_friesen.pdf) [Accessed March 14, 2014].
- [22] Steven J. Durand, "Attaining thirty-year photovoltaic system lifetime", *Progress in Photovoltaics: Research and Applications*, vol. 2, pp. 107-113, 1994.

- [23] Shawn A. Fahrenbruch, Solar Bypass Diodes: Then and Now (Part 2) [online], Available: <http://www.photovoltaic-production.com/1907/solar-bypass-diodes-then-and-now-part-2/>, [Accessed Feb. 10, 2014].
- [24] Michael Kempe, Matt Reese, Arrelaine Dameron, Thomas Moricon, “Types of Encapsulant materials and physical differences between them”, in *Proceedings of the NREL PV Reliability Workshop*, Colorado, 2010. Available: [http://www1.eere.energy.gov/solar/pdfs/pvrw2010\\_kempe.pdf](http://www1.eere.energy.gov/solar/pdfs/pvrw2010_kempe.pdf) [Accessed March 14, 2014].
- [25] M. A. Green, “Silicon Photovoltaic Modules: A brief history of the first 50 years”, *Progress in Photovoltaics: Research and Applications*, vol. 13, no. 5, pp. 447-455, 2005.
- [26] Allan C. O’Connor, Ross J. Loomis, and Fern M. Braun, “Retrospective benefit – cost evaluation of DOE investment in Photovoltaic energy systems” [online], Available: [http://www1.eere.energy.gov/analysis/pdfs/solar\\_pv.pdf](http://www1.eere.energy.gov/analysis/pdfs/solar_pv.pdf) [Accessed March 14, 2014].
- [27] A.W. Czanderna and F.J.Pern, “Encapsulation of PV modules using ethylene vinyl acetate copolymer as a pottant: A critical review”, *Solar Energy Materials and Solar Cells*, vol. 43, pp. 101-181, 1996.
- [28] W. W. Holley and S.C.Argo, “Advanced EVA based encapsulants: Final Report- January 1993 – June 1997”, National Renewable Energy Laboratory, Tech. Rep. NREL/SR-520-26296, 1998.
- [29] Keith R. McIntosh, Nick E. Powell, Ann W. Norris, James N. Cotsell and Barry M. Ketola, “The effect of damp heat and UV aging tests on the optical properties of silicone and EVA encapsulants”, in *Progress in Photovoltaics: Research and Applications*, 19, 2010, pp. 294-300.
- [30] M. D. Kempe, T.J. Moricone, M. Kilkenny, J. Z. Zhang, “Accelerated Stress testing of hydrocarbon based encapsulants for medium CPV applications”, in *Proceedings of the 34th IEEE Photovoltaic Specialists Conference*, Philadelphia, 2009, pp. 1826-1831.
- [31] Cordula Schmidt, Julien Chapon, Geoffrey Kinsey, Jayesh Bokria, Joseph Woods, “Impact of High Light Transmiaaion EVA-based encapsulant on the performance of PV Modules”, *Proceedings of the 27<sup>th</sup> European Photovoltaic Solar Energy Conference and Exhibition*, 2012, pp. 3494 – 3498.
- [32] Shuying Yang and Kent Whitfield, “Thermal endurance study of polymers used in low concentration photovoltaic modules”, *Journal of Photonics for Energy*, vol. 2, 2012. DOI: 10.1117/1.JPE.2.021803.
- [33] PV Magazine, Educating customers and learning from them – backsheets [Online], Available: [http://www.pv-magazine.com/archive/articles/beitrag/educating-customers-and-learning-from-them-\\_100004114#axzz2n3WyHGm1](http://www.pv-magazine.com/archive/articles/beitrag/educating-customers-and-learning-from-them-_100004114#axzz2n3WyHGm1), [Accessed Feb 10, 2014].
- [34] Michelle Lamontagne, The Solar Manufacturer’s Dilemma: Understanding PV backsheet options [Online], Available: [http://www.solarnovus.com/the-solar-manufacturers-dilemma-understanding-pv-backsheet-options\\_N6711.html](http://www.solarnovus.com/the-solar-manufacturers-dilemma-understanding-pv-backsheet-options_N6711.html), [Accessed Jan 5, 2014].

- [35] G. Oreski and G.M.Wallner, “Aging mechanisms for polymeric films for PV encapsulation”, in *Solar Energy*, vol. 79, 2005, pp. 612-617.
- [36] William Gambogi, “Qualification of PV Materials”, Presented at Solar Power International Workshop, Chicago, USA, 2013. Available: [http://www.nrel.gov/pv/performance\\_reliability/pdfs/2013\\_spi\\_wkshp\\_gambogi.pdf](http://www.nrel.gov/pv/performance_reliability/pdfs/2013_spi_wkshp_gambogi.pdf) [Accessed March 14, 2014].
- [37] Namsu Kim, Hyunwoo Kang, Kyung-Jun Hwang, Changwoon Han, Won Sik Hong, Dajung Kim, Eonjoo Lyu, Hwanyeon Kim, “Study on the degradation of different types of backsheets used in PV Module under accelerated conditions”, in *Solar Energy Materials & Solar Cells*, vol. 120, 2014, pp. 543-548.
- [38] Tsuyoshi Shioda, “Delamination failures in long-term field-aged PV modules from point of view of encapsulants,” in *Proceedings of the Photovoltaic Module reliability Workshop*, Colorado USA, 2013. Available:[http://www1.eere.energy.gov/solar/pdfs/pvmrw13\\_openingsession\\_shioda\\_mitsui.pdf](http://www1.eere.energy.gov/solar/pdfs/pvmrw13_openingsession_shioda_mitsui.pdf) [Accessed March 14, 2014].
- [39] N.G. Dhere and M.B. Pandit, “Study of delamination in acceleration tested PV Modules”, in *Proceedings of the 17<sup>th</sup> European Photovoltaic Solar Energy Conference and Exhibition*, Munich, 2001, pp. 572 – 575.
- [40] P. Hülsmann, M. Heck, & M. Köhl, “Simulation of Water Vapor Ingress into PV-Modules under Different Climatic Conditions”. *Journal of Materials*, 2013, Available: <http://www.hindawi.com/journals/jma/2013/102691>. [Accessed March 14, 2014].
- [41] M. Goldstein, L. Dunn, “Light Soaking Effects on PV Modules: Overview and Literature Review,” in *Proceedings of the Photovoltaic Module Reliability Workshop*, 2011, Available: [http://www1.eere.energy.gov/solar/pdfs/pvmrw2011\\_p25\\_tf\\_dunn.pdf](http://www1.eere.energy.gov/solar/pdfs/pvmrw2011_p25_tf_dunn.pdf). [Accessed March 14, 2014].
- [42] Bhushan Sopori, P. Basnyat, S. Shat, V. Mehta, J. Binns and J. Appel, “Understanding Light-Induced Degradation of c-Si Solar Cells”, in *Proceedings of the IEEE Photovoltaic Specialist Conference*, Austin, USA, 2012
- [43] M. Stutzmann, W.B. Jackson, and C.C. Tsai, “Light - induced metastable defects in hydrogenated amorphous silicon: A systematic study,” in *Physical Review B*, vol. 32, 1985, pp. 23-47.
- [44] International Energy agency, “16 Case Studies on the Deployment of Photovoltaic Technology in Developing Countries,” IEA-PVPS publications, Report No. IEA-PVPS T9-07, 2003.
- [45] Yale University School of Management, “SELCO 2009: Determining a path forward,” in Yale University School of Management, 2009. [Online]. Available: <http://nexus.som.yale.edu/design-selco/>. [Accessed 2 October 2013].
- [46] A. Chaurey and T. Kandpal, “Solar lanterns for domestic lighting in India: Viability of central charging,” in *Energy Policy*, no. 39, pp. 4910–4918, 2009.

- [47] S. Bawakyillenuo, “Deconstructing the dichotomies of solar photovoltaic (PV) dissemination trajectories in Ghana, Kenya and Zimbabwe from the 1960s to 2007,” in *Energy Policy*, no. 49, 2012, pp. 410-421.
- [48] M. Jafar, “Renewable Energy in the South Pacific—options and constraints,” in *Renewable Energy*, no. 19, 2000, pp. 305-309.
- [49] S. Ling, J. Twidell and B. Boardman, “Household photovoltaic market in Xining, Qinghai province, China: the role of local PV business,” in *Solar Energy*, vol. IV, no. 73, pp. 227-240, 2002.
- [50] M. El-Shobokshy and F. Hussein, “Degradation of photovoltaic cell performance due to dust deposition on to its surface,” in *Renewable Energy*, vol. III, no. 7, 1993, pp. 585-590.
- [51] A. Benatallah, R. Mostefaou and K. Bradja, “Performance of photovoltaic solar system in Algeria,” in *Desalination*, vol. III, no. 209, 2007, pp. 39-42.
- [52] A. Ubisse and A. Sebitosi, “A new topology to mitigate the effect of shading for small photovoltaic installations in rural sub-Saharan Africa,” in *Energy Conversion and Management*, vol. 7, no. 50, 2009, pp. 1797–801.
- [53] H. Saha, “Design of a Photovoltaic electric power system for an Indian village,” in *Solar Energy*, vol. II, no. 27, 1981, pp. 103–107.
- [54] Schmidt-Kuntzer and G. Schafer, “Village power plants versus SHS,” in *SunWorld*, vol. III, no. 17, 1993, pp. 17-20.
- [55] J. Cust, A. Singh and K. Neuhoff, “Rural Electrification in India: Economic and Institutional aspects of Renewables,” Energy Policy Research Group, University of Cambridge, Cambridge, 2007.
- [56] K. Ulsrud, T. Winther, D. Palit, H. Rohracher and J. Sandgren, “The Solar Transitions research on solar mini-grids in India: Learning from local cases of innovative socio-technical systems,” in *Energy for Sustainable Development*, no. 15, 2011, pp. 293–303.
- [57] D. Palit, “Solar energy programs for rural electrification: Experiences and lessons from South Asia,” in *Energy for Sustainable Development*, no. 17, 2013, pp. 270–279.
- [58] D. Miller and C. Hope, “Learning to lend for off-grid solar power: policy lessons from World Bank loans to India, Indonesia, and Sri Lanka,” in *Energy Policy*, no. 28, 2000, pp. 87-105.
- [59] P. Raman, J. Murali, D. Sakthivadivel and V. Vigneswaran, "Opportunities and challenges in setting up solar photo voltaic based micro grids for electrification in rural areas of India," *Renewable and Sustainable Energy Reviews*, no. 16, 2012, pp. 3320– 3325.
- [60] M. Gandhi, “The real issues of solar energy in India,” in *Renewable Energy*, vol. VI, no. 3, 1995, pp. 191-206.
- [61] N.K. Bansal and G. Minke, “Climatic zones and rural housing in India”, Kernforschungsanlage, Juelich, Germany, 1988

- [62] D.E. Carlson, R. Romero, F. Willing, D. Meakin, L. Gonzalez, R. Murphy, H.R. Moutinho, and M. Al-Jassim, "Corrosion Effects in Thin-Film Photovoltaic Modules", *Progress in Photovoltaics: Research and Applications* 11, 2003, pp. 377-386.
- [63] Masood Hussain, "Linking Ladakh with national grid: PGCIL to implement Rs 2076.56 crore project", [Online], Available: [http://articles.economictimes.indiatimes.com/2014-01-09/news/46030332\\_1\\_pgcil-crore-project-ladakh](http://articles.economictimes.indiatimes.com/2014-01-09/news/46030332_1_pgcil-crore-project-ladakh), [Accessed on Jan 10, 2014].

# Appendix I

## Survey Checklist

---

### Documentation of Module condition

Date 8<sup>th</sup> May, 2013 Name of data recorder: Jim, Arun, Rajiv  
Location Rajgiri College Kerala Site No 1  
Latitude 76.2°E Longitude 9.97°N Altitude 0 m

#### 1. Module Data

Picture Taken <input checked="" type="checkbox"/>
Source: _____
Ref No: _____

Technology:  mono Si  multi Si  a-Si  CdTe  CIGS/CIS  
Other \_\_\_\_\_

Certification:  unknown  UL 1703  IEC 61215  IEC 61646  IEC 61730  
 Other \_\_\_\_\_

Estimated deployment date 2006

Photo taken of nameplate:  yes  no

Manufacturer Not being disclosed

Model # Not being disclosed

Serial # 5615515

Installation Site/Facility Serial # NA

Width 120 cm Length 54 cm

Comments: \_\_\_\_\_

---

Nameplate:  nameplate missing(Data from Tracer)

$P_{max}$  75 W  $V_{oc}$  21.8 V  $I_{sc}$  4.9 A

Sys Volt 43.8 V  $V_{max}$  17 V  $I_{max}$  4.4 A

Bypass diode,  $I_f$  5 A

Series fuse 15 A

**2. System Data**

Picture Taken <input checked="" type="checkbox"/>
Source: _____
Ref No: _____



System design:  single module  multiple modules (a)  unknown

**(a.) Multiple module system:**

Module location/number in a series string (from negative) 2

No of modules in series (string) 1 No of strings in parallel (array) 6

No of bypass diodes 2

No of modules per bypass diode NA

System Bias:  open circuit  resistive load  max. power tracked  short circuit

Unknown  Other: DC water Pump

System Grounding:  grounded (a.)  not grounded  unknown

(a.)  Negative  positive  center of string  unknown

Comments: System Size 900 Watt

---

---

---

**3. Rear-side Glass:**  not applicable  applicable

Picture Taken <input type="checkbox"/>
Source: _____
Ref No: _____

**Damage:**  no damage  small, localized  extensive

Damage Type

crazing or other non--crack damage

shattered (tempered )  shattered (non-tempered )  cracked (a.)  chipped (b.)

(a.) Cracks (no):  1  2  3  4--10  >10

Crack(s) start from:  module corner  module edge  cell  junction box

(b.) Chips (no):  1  2  3  4--10  >10

Chipping location:  module corner  module edge

**4. Backsheet:**  not applicable  applicable

Picture Taken <input checked="" type="checkbox"/>
Source: _____
Ref No: _____



**Appearance:**  like new  minor discoloration  major discoloration

ALL INDIA SURVEY OF PV MODULE DEGRADATION: 2013

**Texture:**  like new  wavy (not delaminated)  wavy (delaminated)  dented

**Damage:**  no damage  small, localized  extensive

**Damage Type**

burn marks (a.)  bubbles (b.)  Delamination (c.)  Cracks/scratches (d.)

(a) Burn marks (no):  1  2  3  4--10  >10

Fraction of area burned:

<5%  5--25%  50%  75% --100% (consistent overall)

(b) Bubbles(no):  1  2  3  4--10  >10

Average bubble dimension:  <5mm  5--30mm  >30mm

(c) Fraction of area delaminated:

<5%  5--25%  50%  75% --100% (consistent overall)

(d) Cracks/scratches (no):  1  2  3  4--10  >10

Cracks/scratches location:  random/no pattern  over cells  between cells

**5. Wires/Connectors:**

Picture Taken <input checked="" type="checkbox"/>
Source: _____
Ref No: _____

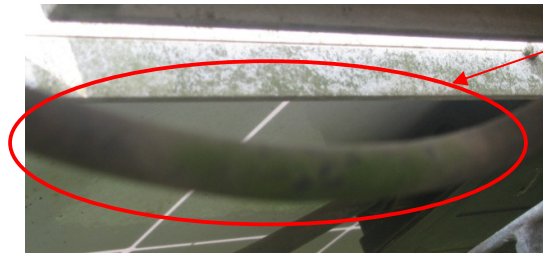

Cable connected to module

**Wires:**  not applicable  like new  pliable, but degraded  embrittled  
 Cracked/disintegrated insulation  burnt  corroded  
 Animal bites/marks

**Connectors:**  not applicable  like new  pliable, but degraded  embrittled

Type:  unsure  MC3 or MC4  Tyco Solarlok  other \_\_\_\_\_

cracked/disintegrated insulation  burnt  corroded

**6. Junction Box:**

Picture Taken	<input checked="" type="checkbox"/>
Source:	_____
Ref No:	_____



**Junction box itself:**  not applicable/observable  applicable  
Physical state:  intact  unsound structure  
 Weathered  cracked  burnt  warped

**Junction box adhesive:**  not applicable/observable  applicable  
Attachment:  well attached  loose/brittle  fell off

**Junction box wire attachments:**  not applicable/observable  applicable  
Attachment:  well attached  loose  fell off  
Seal:  good seal  seal will leak

**7. Frame Grounding:**

Picture Taken	<input checked="" type="checkbox"/>
Source:	_____
Ref No:	_____



**Original state:**  Wired ground  Resistive ground  No ground  unknown

**Appearance:**  Not applicable  Like new  some corrosion  Major corrosion

**Function:**  Well grounded  No connection

**Photos taken of**  back, label, and junction box

**8. Frame:**  not applicable  applicable

Picture Taken

Source: \_\_\_\_\_

Ref No: \_\_\_\_\_



**Appearance:**  like new  damaged (a.)  missing  
 (a)  minor corrosion  major corrosion  frame joint separation  bent frame

Frame cracking

**Frame Adhesive:**  like new/not visible  degraded

**9. Glass/Polymer (front):**

Picture Taken

Source: \_\_\_\_\_

Ref No: \_\_\_\_\_

ALL INDIA SURVEY OF PV MODULE DEGRADATION: 2013

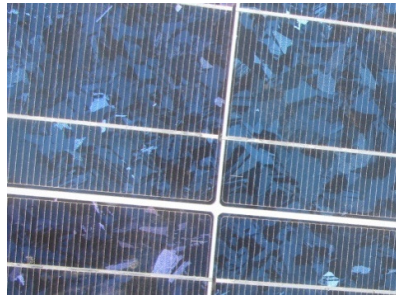

- Material:**  glass  polymer  glass/polymer composite  unknown
- Features:**  smooth  slightly textured  pyramid/wave texture  antireflection coating
- Damage:**  no damage  small, localized  extensive

Damage Type

- shattered (tempered)  shattered (non--tempered )  Cracked (a.)  Chipped (b.)
- (a.) Cracks (no):  1  2  3  4--10  >10  
 Crack(s) start from:  module corner  module edge  cell  junction box
- (b.) Chips (no):  1  2  3  4--10  >10  
 Chipping location:  module corner  module edge
- (c) Fraction of area:  
 <5%  5-25%  50%  75% - 100% (consistent overall)

**10. Metallization:**

Picture Taken

Source: \_\_\_\_\_

Ref No: \_\_\_\_\_

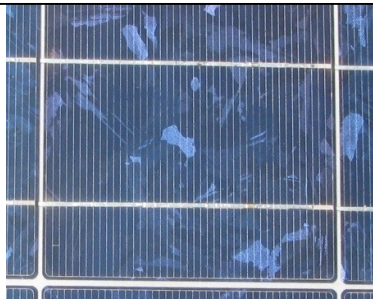

- Gridlines/Fingers:**  not applicable/barely observable  applicable  
Appearance:  like new  light discoloration (a.)  dark discoloration(a.)
- (a.) Fraction of discoloration:  
 <5%  5-25%  50%  75% - 100% (consistent overall)
- Busbars:**  not applicable/barely observable  applicable  
Appearance:  like new  light discoloration (a.)  dark discoloration (a.)

ALL INDIA SURVEY OF PV MODULE DEGRADATION: 2013

(a.) Fraction of discoloration:

<5%  5-25%  50%  75% - 100% (consistent overall)

**Cell Interconnect Ribbon:**

not applicable/barely observable  applicable

Appearance:  like new  light discoloration(a.)  dark discoloration(a.)

(a.) Fraction of discoloration:

<5%  5-25%  50%  75% - 100% (consistent overall)

**String Interconnect:**

not applicable/barely observable  applicable

Appearance:  like new  light discoloration(a.)  dark discoloration(a.)

(a.) Fraction of discoloration:

<5%  5-25%  50%  75% - 100% (consistent overall)

**11. Silicon (mono or multi) module:**

not applicable  applicable

Picture Taken

Source: \_\_\_\_\_

Ref No: \_\_\_\_\_



Number of: Cells in module 36 Cells in series/string 36

Strings in parallel 0

Cell size: Width 12 cm Length 12 cm

Diameter: NA cm

Distance between frame and cell:  >10 mm  <10 mm

Distance between cells in a string:  >1 mm  <1 mm

**Discoloration:**  none/like new  light discoloration  dark discoloration

Number of cells with any discoloration: 16

Average % discolored area:

<5%  5-25%  50%  75% - 100% (consistent overall)

Discoloration location(s) (mark all that apply):

module center  module edges  cell centers  cell edges

ALL INDIA SURVEY OF PV MODULE DEGRADATION: 2013

over gridlines     over busbars     over tabbing     between cells

Junction box area:     same as elsewhere     more affected     less affected

**Damage:**     none

burn mark (a.)     cracking (b.)     moisture worm marks/snail tracks

(a.) Burns (no):     1     2     3     4-10     >10

(b.) Number of cells cracked: \_\_\_\_\_

(c.) Number of cells with worm marks/snail tracks: \_\_\_\_\_

**Delamination:**     none     from edges     uniform     corner(s)     near junction box

between cells(a)     over cells(b)     near cell or string interconnect

(a.) Fraction delaminated between cells:

<5%     5-25%     50%     75% - 100% (consistent overall)

(b.) Fraction delaminated over cells:

<5%     5-25%     50%     75% - 100% (consistent overall)

**12. Thin film module:**     not applicable     applicable

Picture Taken

Source: \_\_\_\_\_

Ref No: \_\_\_\_\_

Number of cells:

Number of cells in module \_\_\_\_\_

Number of cells in series/string \_\_\_\_\_

Number of strings in parallel \_\_\_\_\_

Cell size: Width \_\_\_\_\_ cm Length \_\_\_\_\_ cm

**Appearance:**     like new     minor/light discoloration     major/dark discoloration

Discoloration location

overall/no location pattern     module center     module edge(s)

cell center     cell edges     near crack(s)

**Damage:**     no damage     small, localized     extensive

**Delamination:**     no Delamination     small, localized     extensive

Location:     from edges     uniform     corner(s)     near junction box     near busbar

**Photos taken of**     front and defects

ALL INDIA SURVEY OF PV MODULE DEGRADATION: 2013

**13. Electronic Records**  not applicable  applicable

Photographs and I-V curves recorded electronically

I-V curve

Taken by which tracer  Meco Module Analyzer  Meco System Analyzer

File number/name Record 000047

Morning  Afternoon  Evening

Irradiance See Data Sensor Reference Solar cell

Temperature See Data Sensor RTD

IR picture Yes

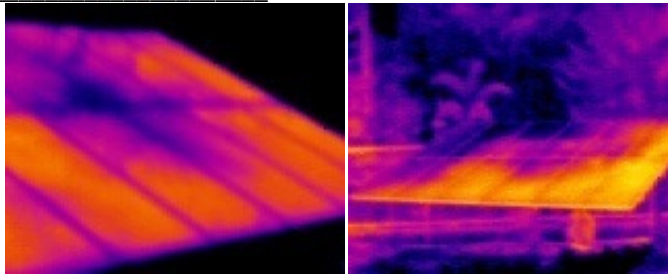

(NOTE : Blue colour represents cooler regions, while orange colour represents hotter regions in above IR image).

Contactless current measurement done  yes  no

**Module Condition**

String No	1	2	3	4	5	6
Open Ckt Reading						
Short ckt Reading						

Bypass Diode Test:  not applicable  applicable

Number of diodes:

In total 2,

shorted 0, open 2

**14. Inverter**

Connected :  yes  no

Located  indoor  outdoor

ALL INDIA SURVEY OF PV MODULE DEGRADATION: 2013

Inverter environment :

Temperature: \_\_\_\_\_

Drop of water/liquid :  yes  no

Unit/components:

Vibration and noise:  Good  Need Attention  NA

Earth connected  Good  Need Attention  NA

Operation Data:

Input side(DC)

(1) Current \_\_\_\_\_

(2) Voltage \_\_\_\_\_

(3) Power \_\_\_\_\_

Output side(AC)

(1) Current \_\_\_\_\_

(2) Voltage \_\_\_\_\_

(3) Power \_\_\_\_\_

Efficiency ( $\eta$ ) \_\_\_\_\_

Max Power \_\_\_\_\_

**15.Battery**

Connected :  yes  no

Manufacture \_\_\_\_\_

Battery voltage and Ah rating \_\_\_\_\_

Date of Installation \_\_\_\_\_

How often battery is changed : \_\_\_\_\_

Battery end terminals connection tight:  yes  no

Equal level of electrolyte in all the cells  yes  no

Specific gravity before/after charge:  OK  Need Attention  NA

Check battery terminal for correction  OK  Need Attention  NA

ALL INDIA SURVEY OF PV MODULE DEGRADATION: 2013

**16. History of Climate**

Place Kochi

Max Temperature 30 °C

Min Temperature 25 °C

Annual mean Temperature 27 °C

Wind Speed 12 kmph

Wind Direction \_\_\_\_\_

Cloud cover \_\_\_\_\_

Mean sea level pressure 760 mm Hg

Liquid precipitation 2740 mm

Max Humidity Annual Avg. Humidity in Morning : 90%

Min Humidity Annual Avg Humidity in Evening : 72%

Radiation 5.3 kWh/m<sup>2</sup>/day

**17. Surroundings :**

Appearance of Glass:  clean  lightly soiled  heavily soiled

Location of soiling:

Locally soiled near frame:

left  right  top  bottom  all sides

locally soiled on glass /bird droppings

Soiling sample taken on glass slides  yes  no

Cleaning interval Once in two weeks

Last cleaned on (date) 7<sup>th</sup> May , 2013 (Rain)

Shading: % area of modules:  
 <25  <50  <75  whole

Kind of shading:  building  Trees

Any reflecting surface nearby  yes  no

Tilt angle 18°

Direction of PV panels South

**18.Mounting Structure Details:**



**Material used:** Galvanized Iron with Powder Coating \_\_\_\_\_

**Condition of structure**  good  bad (a)

(a)  Rusted  bent  broken

Where it is installed  roof top  ground

**19.Social :**

**Maintenance**  preventive  responsive

What kind of maintenance: Cleaning, Inspection \_\_\_\_\_

Which items have been frequently replaced and need maintenance : NO parts replaced \_\_\_\_\_

Maintenance done by (owner/Company person) Company person \_\_\_\_\_

**Maintenance:**  monthly  half yearly  annually

**Training of Technicians:**  well trained  moderately trained  slightly trained

**Grid has come or not:**  Yes  No

- End usage:**
- 1) Light
  - 2) Fan
  - 3) Hospital
  - 4) Animal husbandry
  - 5) Refrigeration
  - 6) Others: DC water pump(1 hp) \_\_\_\_\_

**Cost of the system and year of purchase:** Rs. 1.8 Lakh with pump, in 2006 \_\_\_\_\_

**Funded by (CSR/Govt/self)** self \_\_\_\_\_

ALL INDIA SURVEY OF PV MODULE DEGRADATION: 2013

Subsidy  yes(a)  no

(a) Amount : Rs 90000 MNRE ,through ANERT

Community usage  yes  no

Comments :Permanent magnet pump (Rs 15000)

**Module Name Plate Details:**

<b>Name Plate Rating</b>	75 Watts
<b>Operating Data</b>	
V <sub>oc</sub>	19.94 Volts
I <sub>sc</sub>	3.6 Amperes
P <sub>max</sub>	40.4 Watts
Irradiance	835 W/m <sup>2</sup>
Temperature	40.0° C
Fillfactor	43 %

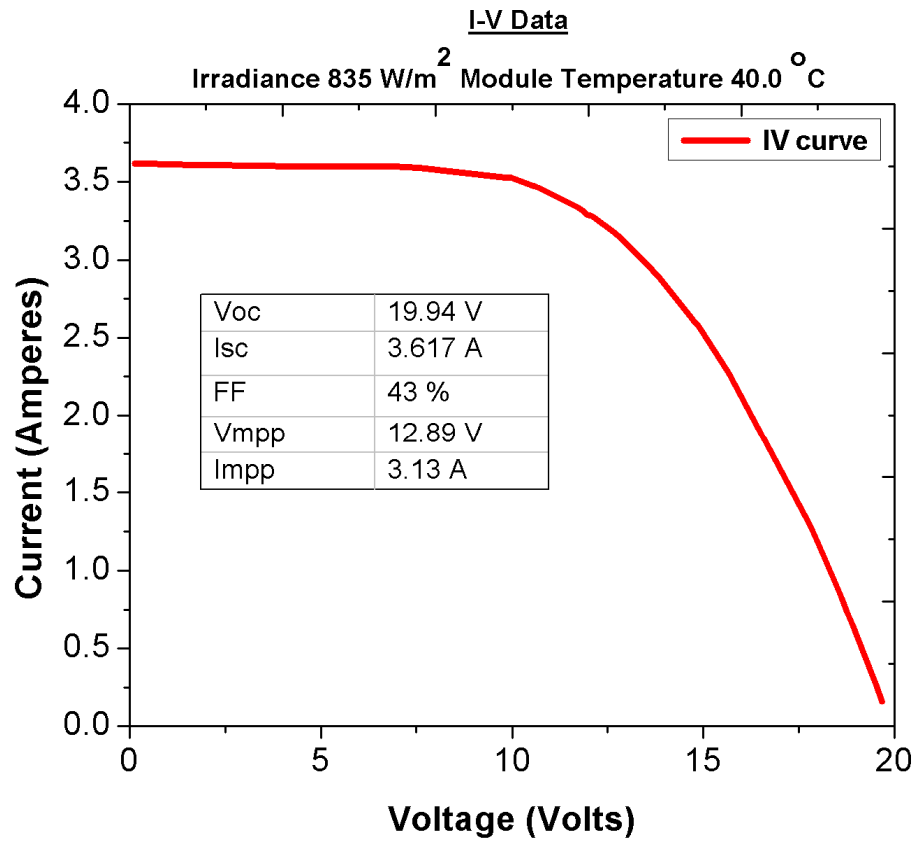

## Appendix II

# Software package for STC correction

---

The STC correction for the measured I-V data was done by using Procedure 1a correction procedure. A MATLAB code was written in order to do the correction of the measured I-V data. It uses the equations of the Procedure 1a. The step by step process of the I-V data correction by using MATLAB code is given below:

### Step 1:

It asks for the excel file of the measured I-V data that is to be corrected to STC. We can browse it from the computer directory and then we can select the required I-V data file for STC correction (refer Fig. A).

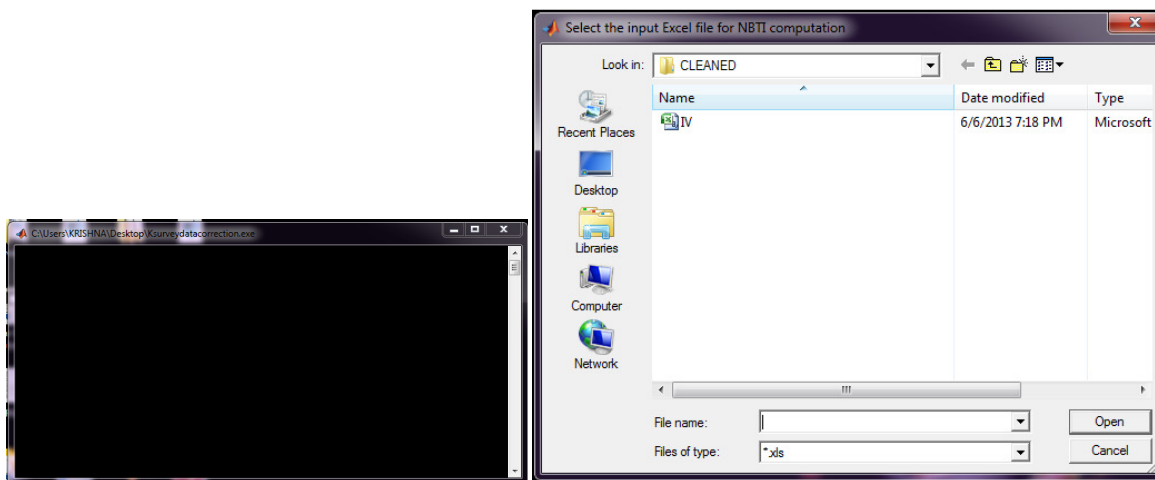

Fig. A: Snap Shot of screen 1 of the MATLAB code for selecting excel file for STC correction.

### Step 2:

Then it asks for some information like module wattage, module temperature coefficients, year of deployment, site no and module number (because at some sites more than one module of different make or technology was inspected).

```

C:\Users\KRISHNA\Desktop\Ksurveydatacorrection.exe
Enter the rated Wattage of module
The wattage rating of module: 75
Enter the value of alpha: 0.10
Enter the value of beta: -0.12
Enter the year of deployment: 2000
Enter the site no: 17
Enter the module Number =:b_

```

Fig. B: Snap shot of screen 2 of the MATLAB code for entering module information.

### Step 3:

After giving the module related information, it displays the list of irradiance and fill factor values from the logged data of the selected file. Then we can choose one set of values from the whole list by entering the serial number (Sr. No.) of that set. This means that it will translate that I-V data which was measured at irradiance of  $825 \text{ W/m}^2$  and having a fillfactor of 56%.

```

C:\Users\KRISHNA\Desktop\Ksurveydatacorrection.exe
Values of Irradiance and Temperature choose one of it
Sr. No:1   Irradiance=835   Fillfactor=5.600000e+001
Sr. No:2   Irradiance=832   Fillfactor=49
Sr. No:3   Irradiance=836   Fillfactor=4.070000e+001
The Sr. No of Data to be corrected : 1

```

Fig.C: Snapshot of screen 3 of the MATLAB code.

### Step 4:

Then it displays the plot of I-V data set selected and if we want to change the selection it asks “Want to check with more data (1(yes)/0(no))”. If we press 1 it returns back to the previous step3 and again shows the list of irradiance and fill factor; if we press 0 it goes to the next step and does the STC correction (refer Fig: D and E).

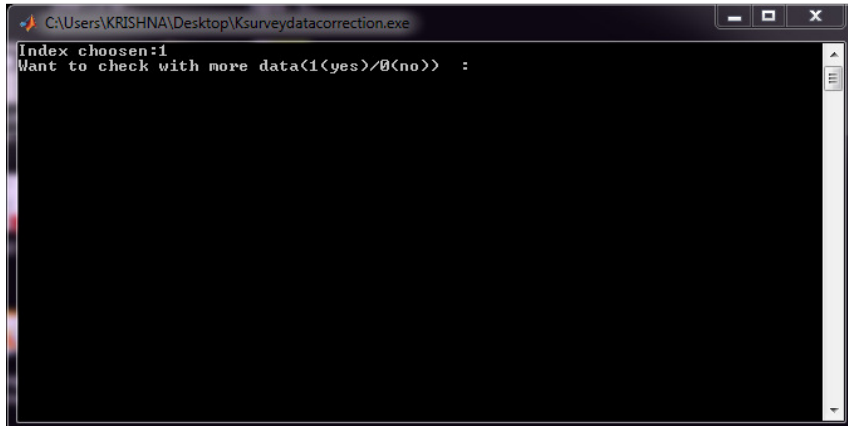

Fig. D: Snap shot of screen 4 of the MATLAB code

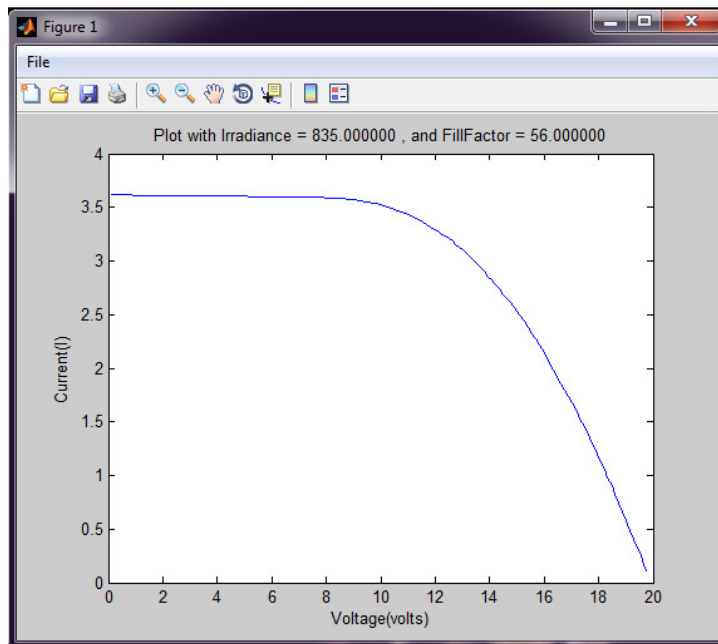

Fig. E: Snap shot of screen 4 of the MATLAB code showing the I-V curve of the selected Sr.No.

**Step 5:**

This step shows a graph of measured I-V data (Blue line) and STC corrected I-V data (Green line) on the same plot (refer Fig: G). Along with the plot it gives the value of  $V_{oc}$ ,  $I_{sc}$ ,  $P_{max}$  at operating condition as well as at STC condition (refer Fig: F). It asks for more files for correction– “want to enter more (1/0)”. If we press 0 it writes a file in the same directory from where the I-V data was selected. A sample file is shown below:

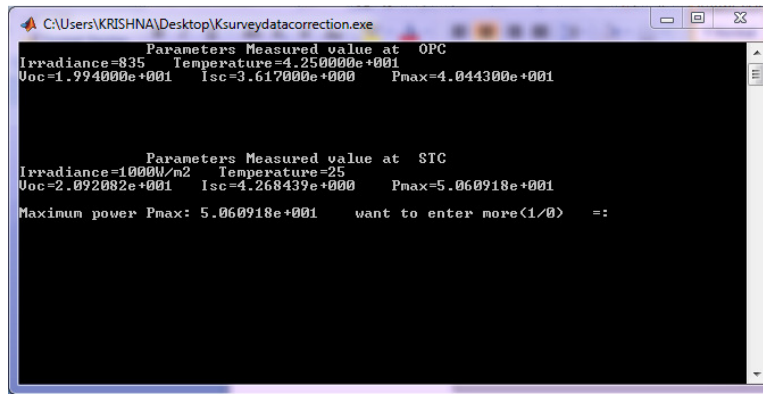

Fig. F: Snap shot of screen 5 of the MATLAB code showing the corrected value at STC

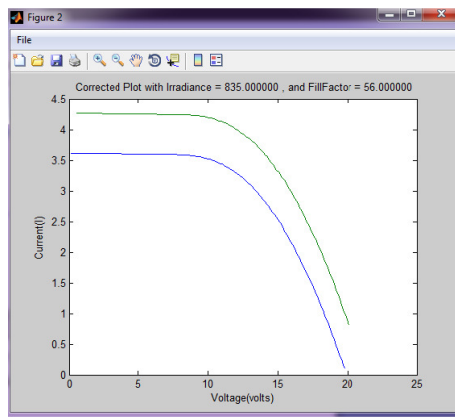

Fig. G: Snapshot of screen 5 of the MATLAB code showing the curve of the measured I-V data (blue line) and corrected I-V data at STC (green line)

**Sample file:**

<b>Wattage(Watts)</b>	75				
<b>OPC Data</b>		<b>STC Data</b>		<b>Percentage Degradation(%/year)</b>	2.50
<b>Voc (Volts)</b>	19.94	<b>Voc(Volts)</b>	20.92	<b>Year of Deployment</b>	2000
<b>Isc (Amp)</b>	3.617	<b>Isc (Amp)</b>	4.27	<b>Series Resistance(<math>\Omega</math>)</b>	1.43
<b>Irradiance (W/m<sup>2</sup>)</b>	835	<b>Irradiance (W/m<sup>2</sup>)</b>	1000	<b>Shunt Resistance(<math>\Omega</math>)</b>	Infinity
<b>Temperature (°C)</b>	40	<b>Temperature (°C)</b>	25	<b>Temperature Coefficients</b>	
<b>Fill factor (%)</b>	43	<b>Fill factor (%)</b>	57	<b>Alpha(Amp/C)</b>	0.003617
		<b>Power at STC(Watts)</b>	50.61	<b>Beta(Volts/C)</b>	-0.02393

ALL INDIA SURVEY OF PV MODULE DEGRADATION: 2013

Measured I-V data		STC Corrected I-V data	
Voltage(Volts)	Current(Amp)	Voltage(Volts)	Current(Amp)
0.13	3.62	0.55	4.27
0.26	3.62	0.68	4.27
0.39	3.62	0.81	4.27
1.72	3.61	2.14	4.26
2.12	3.61	2.54	4.26
4.38	3.60	4.80	4.26
4.52	3.60	4.94	4.26
5.71	3.60	6.13	4.25
5.85	3.60	6.27	4.25
5.98	3.60	6.40	4.25
6.91	3.60	7.33	4.25
7.57	3.59	7.99	4.25
9.83	3.53	10.25	4.18
9.97	3.53	10.39	4.18
10.5	3.48	10.92	4.13
10.63	3.47	11.05	4.12
11.3	3.39	11.72	4.05
11.7	3.34	12.12	3.99
11.83	3.32	12.25	3.97
11.96	3.29	12.38	3.94
12.09	3.28	12.51	3.93
12.63	3.18	13.05	3.84
12.76	3.16	13.18	3.81
12.89	3.13	13.31	3.78
13.29	3.03	13.71	3.69
13.69	2.93	14.11	3.59
13.82	2.90	14.24	3.55
14.75	2.61	15.17	3.26
14.89	2.57	15.31	3.22
15.68	2.27	16.10	2.92
17.81	1.28	18.23	1.93
18.08	1.13	18.50	1.78
18.61	0.83	19.03	1.48
18.74	0.74	19.16	1.39
18.88	0.66	19.30	1.31
19.41	0.33	19.83	0.98
19.54	0.26	19.96	0.91
19.67	0.16	20.09	0.82

# Appendix III

## Site-wise analysis

<b>Site No.:</b> 1	<b>Location:</b> Kakkannad (Kochi)	<b>Climatic Zone:</b> Hot & Humid
<b>Module No.</b> A	<b>Type:</b> Multi Crystalline Silicon	<b>Power Rating:</b> 75 Wp <b>Age:</b> 7 years
<b>Degradation Present</b>	<b>Encapsulant:</b> Yes	<b>Backsheet:</b> No
<b>Details</b>	<b>Metallization:</b> Yes	<b>Junction Box:</b> No
	<b>Frame:</b> Yes	
	<b>Light Discoloration, Delamination</b>	<b>Like New</b>
		<b>Light Corrosion</b>
		<b>Intact &amp; Good Seal</b>
		<b>Minor damage &amp; corrosion</b>
<b>Module Soiling:</b> Lightly Soiled	<b>Shaded Area:</b> 25 – 75%	<b>Maintenance:</b> Responsive
		<b>End Use:</b> DC Water Pump

**Electrical Performance:**

Degradation in Pmax (% per year *)	0.05
Degradation in Isc (% per year *)	-0.36
Degradation in Voc (% per year *)	0.24

\* Based on I-V Curve correction using assumed values for various coefficients (alpha = 0.12% per C, beta = -0.2% per C, Rs=0 & k=0) and assuming linear rate of degradation with time.

**Key Observations:**

- Yellow discoloration and delamination in 1 cell
- Discoloration in the Metallization (fingers)
- Green discoloration in Frames and in junction box terminals (probably due to Algae growth)
- Tilt angle of Module is 18 deg. whereas Latitude is 9 deg. (Non-optimum tilt)
- Heavy shading from nearby trees, which will degrade the module performance

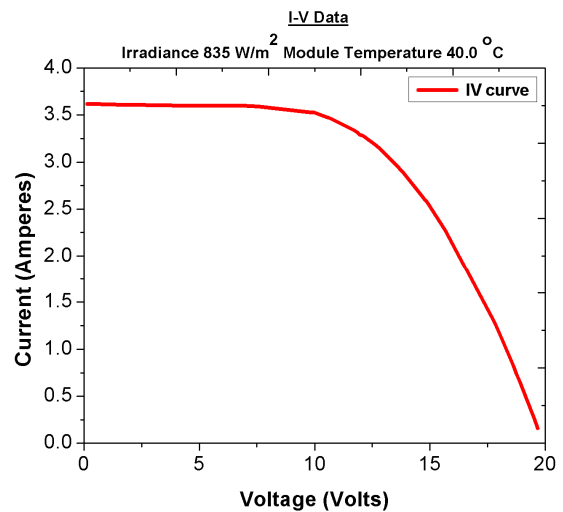

**Recommendations:**

Tilt Angle should be rectified and nearby trees to be pruned to get higher energy generation and longer module life. Modules should be cleaned at least once a week since dust on the modules can reduce the power generation.

**Yellow Discoloration**

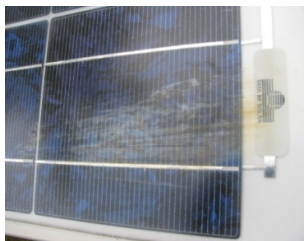

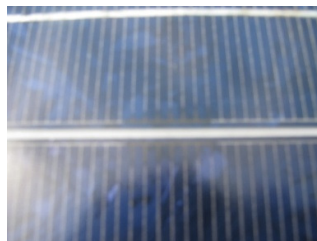

**Discoloration in Metallization**



**Corrosion & Algae growth on frame**



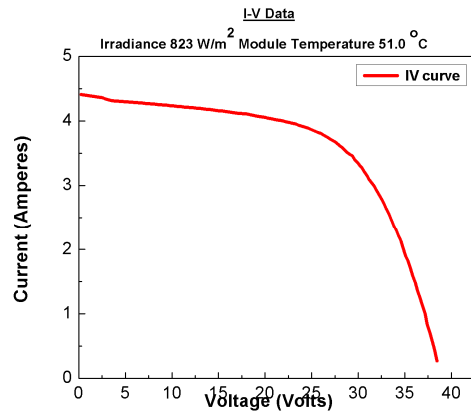

## ALL INDIA SURVEY OF PV MODULE DEGRADATION: 2013

<b>SITE-WISE DATA &amp; ANALYSIS</b>							
<b>Site No.:</b>	2	<b>Location</b> :	Kakkanad (Kochi)	<b>Climatic Zone:</b>	Hot & Humid		
<b>Module No. :</b>	A	<b>Type:</b>	a-Si multi junction	<b>Power Rating:</b>	128 Wp	<b>Age:</b>	6 months
	<b>Encapsulant</b>	<b>Backsheet</b>	<b>Metallization</b>	<b>Junction Box</b>	<b>Frame</b>		
<b>Degradation Present</b>	No	No	NA	No	NA		
<b>Details</b>	Like New	Like New	NA	Intact & Good Seal	NA		
<b>Module Soiling:</b>	Lightly Soiled	<b>Shaded Area:</b>	0 – 25 %	<b>Maintenance</b> :	Responsive	<b>End Use:</b>	Light , Fan
<b>Electrical Performance:</b>							
Degradation in Pmax (% per year *)	1.13						
Degradation in Isc (% per year *)	4.11						
Degradation in Voc (% per year *)	6.41						
* Based on I-V Curve correction using assumed values for various coefficients (alpha = 0.12% per C, beta = -0.2% per C, Rs=0 & k=0) and assuming linear rate of degradation with time.							
<b>Key Observations:</b>							
<ul style="list-style-type: none"> <li>The module surface is undulating (wavy) indicating improper installation</li> <li>Some of the modules have suffered scratches on the top surface.</li> <li>The spacing between the module stands is too small which will cast shadow on the row behind.</li> <li>Tilt angle of Module is 26 deg. whereas Latitude is 9.9 deg. (Non-optimum tilt)</li> </ul>							
<b>Recommendations:</b>							
The distance between the module supporting stands should be increased so as to prevent shading of the modules. The Modules should be placed at Latitude Tilt so as to maximize the annual energy generation. Modules should be cleaned at least once a week since dust on the modules can reduce the power generation.							
<b>Undulating surface of the modules</b>		<b>Scratches and soiling on modules</b>		<b>Insufficient spacing between modules</b>			
							





ALL INDIA SURVEY OF PV MODULE DEGRADATION: 2013

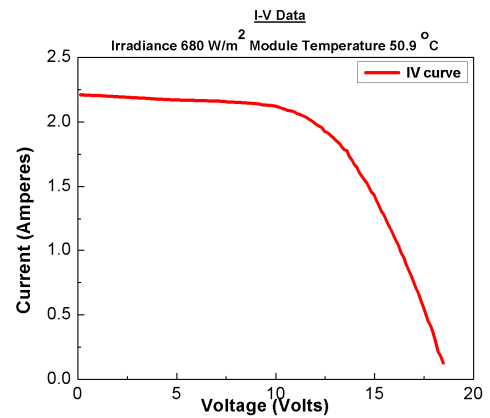

SITE-WISE DATA & ANALYSIS							
<b>Site No.:</b>	3	<b>Location:</b>	Energy park (Kochi)	<b>Climatic Zone:</b>	Hot & Humid		
<b>Module No.:</b>	A	<b>Type:</b>	Mono Crystalline Silicon	<b>Power Rating:</b>	75 Wp	<b>Age:</b> 11 years	
<b>Degradation Present</b>		<b>Encapsulant</b>	Yes	<b>Backsheet</b>	Yes	<b>Metallization</b>	Yes
<b>Details</b>			Dark Discoloration, None	<b>Junction Box</b>	No	<b>Frame</b>	Yes
			Minor Discoloration	<b>Metallization</b>	Dark Corrosion	<b>Junction Box</b>	Intact & Good Seal
				<b>Frame</b>	Minor damage & corrosion		
<b>Module Soiling:</b>	Lightly Soiled	<b>Shaded Area:</b>	0-25%	<b>Maintenance :</b>	Responsive	<b>End Use:</b>	DC Water Pump
<b>Electrical Performance:</b>							
Degradation in Pmax (% per year *)	1.73						
Degradation in Isc (% per year *)	0.95						
Degradation in Voc (% per year *)	-1.1						
* Based on I-V Curve correction using assumed values for various coefficients (alpha = 0.12% per C, beta = -0.2% per C, Rs=0 & k=0) and assuming linear rate of degradation with time.							
<b>Key Observations:</b>							
<ul style="list-style-type: none"> <li>• Dark discoloration covering 90% of the solar cells</li> <li>• Puncture in the backsheet</li> <li>• Green discoloration in Frames (probably due to Algae growth)</li> </ul>							
<b>Recommendations:</b>							
Modules need to be handled carefully in future installations so as to avoid punctures and scratches in the backsheet. Algae growth in the backsheet and frame needs to be prevented as it can reduce the heat conduction rate (which will increase the module operating temperature) and also cause corrosion. Modules should be cleaned at least once a week since dust on the modules can reduce the power generation.							
<b>Dark Discoloration on Module</b>		<b>Puncture in backsheet</b>		<b>Corrosion &amp; Algae growth on frame</b>			
							

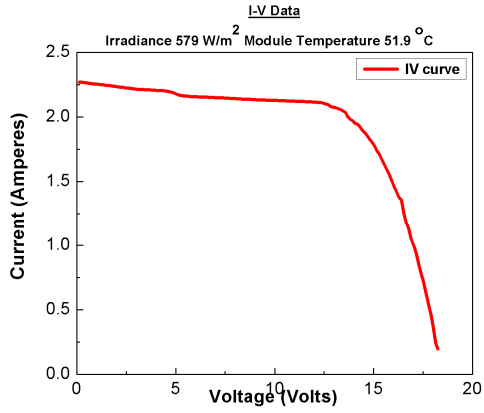
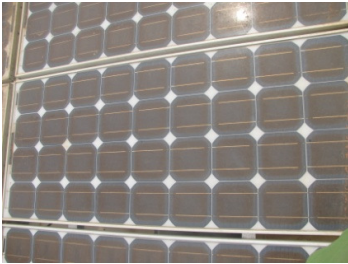
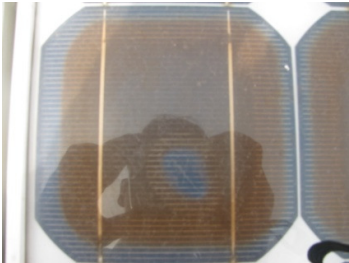

## ALL INDIA SURVEY OF PV MODULE DEGRADATION: 2013

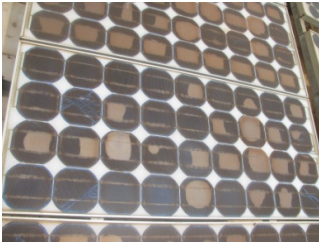
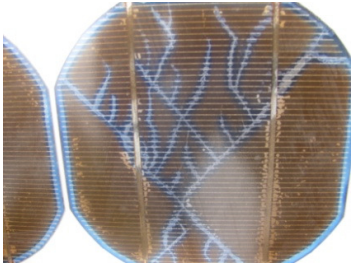

<b>SITE-WISE DATA &amp; ANALYSIS</b>					
<b>Site No.:</b> 4	<b>Location:</b> Auroville	<b>Climatic Zone:</b> Hot & Humid			
<b>Module No. :</b> A	<b>Type:</b> Mono Crystalline Silicon	<b>Power Rating:</b> 75 Wp	<b>Age:</b> 16 years		
	<b>Encapsulant</b>	<b>Backsheet</b>	<b>Metallization</b>	<b>Junction Box</b>	<b>Frame</b>
<b>Degradation Present</b>	Yes	No	Yes	No	No
<b>Details</b>	Dark Discoloration, No Delamination	Like New	Dark Corrosion	Intact & Good Seal	Like new
<b>Module Soiling:</b> Lightly Soiled	<b>Shaded Area:</b> 0 -25%	<b>Maintenance:</b> Responsive	<b>End Use:</b> Light, Fan , PC		
<b>Electrical Performance:</b>					
Degradation in Pmax (% per year *)	1.49				
Degradation in Isc (% per year *)	1.08				
Degradation in Voc (% per year *)	-0.34				
* Based on I-V Curve correction using assumed values for various coefficients (alpha = 0.12% per C, beta =-0.2% per C, Rs=0 & k=0) and assuming linear rate of degradation with time.					
<b>Key Observations:</b>					
<ul style="list-style-type: none"> <li>• Yellow discoloration on modules</li> <li>• Crack in solar cell lead to photo-oxidative bleaching of EVA</li> <li>• Chalking (white powder) of backsheet</li> </ul>					
					
<b>Recommendations:</b>					
When multiple modules are in series, the performance of the system is limited by the most degraded module. So to improve performance, the worst performing modules should be removed from the circuit. Modules should be cleaned at least once a week since dust on the modules can reduce the power generation.					
<b>Yellow Discoloration</b>		<b>Crack in the solar cell leading to photo-bleaching of discolored EVA</b>		<b>Chalking (white powder) of backsheet</b>	
					

ALL INDIA SURVEY OF PV MODULE DEGRADATION: 2013

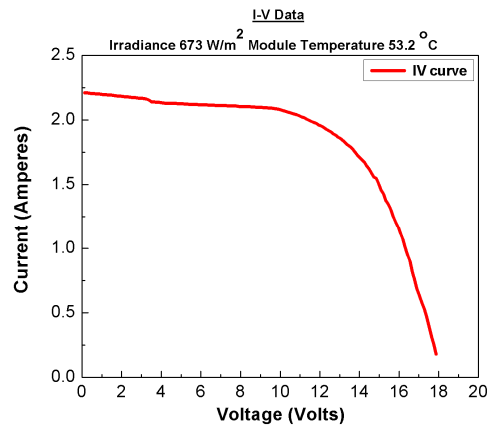
SITE-WISE DATA & ANALYSIS							
<b>Site No.:</b>	4	<b>Location:</b>	Auroville	<b>Climatic Zone:</b>	Hot & Humid		
<b>Module No. :</b>	B	<b>Type:</b>	Mono Crystalline Silicon	<b>Power Rating:</b>	75 Wp	<b>Age:</b>	18 years
<b>Degradation Present</b>	<b>Encapsulant</b>	<b>Backsheet</b>	<b>Metallization</b>	<b>Junction Box</b>	<b>Frame</b>		
	Yes	No	Yes	No	No		
<b>Details</b>	Dark Discoloration, No Delamination	Like New	Dark Corrosion	Intact & Good Seal	Like new		
<b>Module Soiling:</b>	Lightly Soiled	<b>Shaded Area:</b>	0 -25%	<b>Maintenance:</b>	Responsive	<b>End Use:</b>	Light, Fan , PC
<b>Electrical Performance:</b>							
Degradation in Pmax (% per year *)	2.48						
Degradation in Isc (% per year *)	1.84						
Degradation in Voc (% per year *)	0.37						
* Based on I-V Curve correction using assumed values for various coefficients (alpha = 0.12% per C, beta =-0.2% per C, Rs=0 & k=0) and assuming linear rate of degradation with time.							
<b>Key Observations:</b>							
<ul style="list-style-type: none"> <li>Major delamination and discoloration in most of the solar cells</li> <li>Cracks in the solar cell revealed by the photo oxidative bleaching of the discoloured encapsulant</li> <li>Corrosion in the cell and string interconnects</li> </ul>							
<b>Recommendations:</b>							
The presence of degraded module in series with better modules is going to limit the performance of the system so it is better to get rid of modules that have degraded significantly more than others. Modules should be cleaned at least once a week since dust on the modules can reduce the power generation.							
<b>Major delamination &amp; Yellow Discoloration</b>		<b>Cracks in the solar cell</b>		<b>Corrosion in the cell and string interconnects</b>			
							

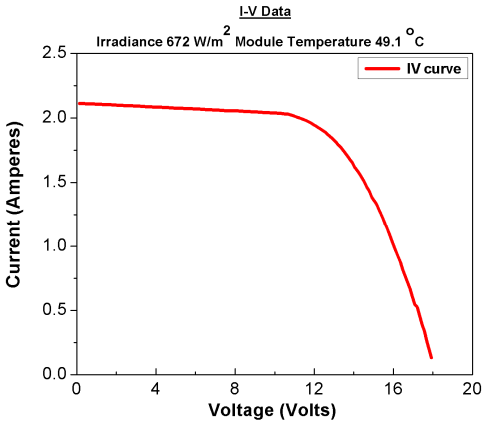
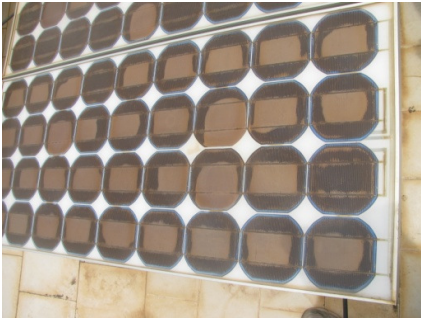
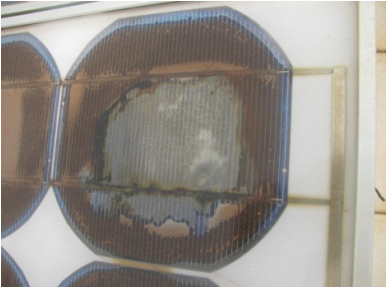

ALL INDIA SURVEY OF PV MODULE DEGRADATION: 2013

SITE-WISE DATA & ANALYSIS						
<b>Site No.:</b>	4	<b>Location:</b>	Auroville	<b>Climatic Zone:</b>	Hot & Humid	
<b>Module No. :</b>	C	<b>Type:</b>	Mono Crystalline Silicon	<b>Power Rating:</b>	75 Wp	<b>Age:</b> 18 years
	<b>Encapsulant</b>	<b>Backsheet</b>	<b>Metallization</b>	<b>Junction Box</b>	<b>Frame</b>	
<b>Degradation Present</b>	Yes	No	Yes	No	Yes	
<b>Details</b>	Dark Discoloration, Delamination	Minor Discoloration	Light Corrosion	Intact & Good Seal	Minor damage & corrosion	
<b>Module Soiling:</b>	Lightly Soiled	<b>Shaded Area:</b>	0-25%	<b>Maintenance:</b>	Responsive	<b>End Use:</b> Light, Fan , PC
<b>Electrical Performance:</b>						
Degradation in Pmax (% per year *)	2.61					
Degradation in Isc (% per year *)	1.97					
Degradation in Voc (% per year *)	0.12					
* Based on I-V Curve correction using assumed values for various coefficients (alpha = 0.12% per C, beta =-0.2% per C, Rs=0 & k=0) and assuming linear rate of degradation with time.						
<b>Key Observations:</b>						
<ul style="list-style-type: none"> <li>• Module has heavy discoloration or delamination</li> <li>• Puncture and discoloration in backsheet</li> <li>• Corrosion in the terminals</li> </ul>						
						
<b>Recommendations:</b>						
The most degraded module in a series string of multiple modules limits the performance of the entire string, so it is better to remove the worst modules from the series string. Modules should be cleaned at least once a week since dust on the modules can reduce the power generation.						
<b>Major delamination and discoloration</b>		<b>Corrosion of Cell Interconnects, major delamination</b>		<b>Breakage in glass</b>		
						

## ALL INDIA SURVEY OF PV MODULE DEGRADATION: 2013

SITE-WISE DATA & ANALYSIS					
<b>Site No.:</b> 4	<b>Location:</b> Auroville	<b>Climatic Zone:</b> Hot & Humid			
<b>Module No.:</b> D	<b>Type:</b> Mono Crystalline Silicon	<b>Power Rating:</b> 37 Wp	<b>Age:</b> 18 years		
<b>Degradation Present</b>	<b>Encapsulant</b> Yes	<b>Backsheet</b> No	<b>Metallization</b> Yes	<b>Junction Box</b> No	<b>Frame</b> Yes
<b>Details</b>	Light Discoloration, No Delamination	Like New	Light Corrosion	Intact & Good Seal	Minor damage & corrosion
<b>Module Soiling:</b>	Lightly Soiled	<b>Shaded Area:</b>	0 -25%	<b>Maintenance:</b>	Responsive
				<b>End Use:</b>	Light, Fan , PC

### Electrical Performance:

Degradation in Pmax (% per year *)	1.53
Degradation in Isc (% per year *)	0.99
Degradation in Voc (% per year *)	-7.16

\* Based on I-V Curve correction using assumed values for various coefficients (alpha = 0.12% per C, beta = -0.2% per C, Rs=0 & k=0) and assuming linear rate of degradation with time.

### Key Observations:

- Module has no discoloration or delamination
- Puncture and discoloration in backsheet
- Corrosion in the output terminals

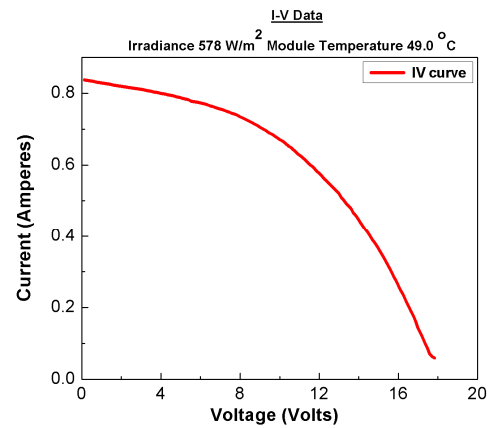

### Recommendations:

Module should be handled carefully so as to avoid any scratches and punctures in the backsheet, which could enhance the degradation rate of the module. Junction Boxes should be tightly sealed against entry of water since corrosion of terminals can lead to loss in power output (which seems to be the reason behind the high Pmax degradation in this case). Modules should be cleaned at least once a week since dust on the modules can reduce the power generation.

**No Discoloration**



**Scratches in backsheet**





**Corrosion in output terminals**



ALL INDIA SURVEY OF PV MODULE DEGRADATION: 2013

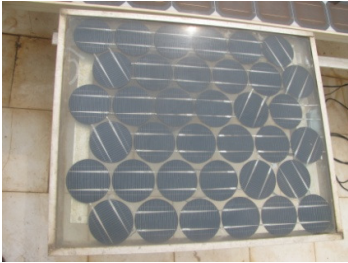
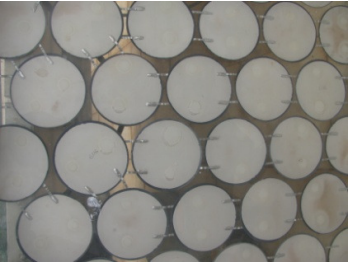

SITE-WISE DATA & ANALYSIS					
<b>Site No.:</b> 4	<b>Location:</b> Auroville	<b>Climatic Zone:</b>		Hot & Humid	
<b>Module No. :</b> E	<b>Type:</b> Mono Crystalline Silicon	<b>Power Rating:</b> 37 Wp	<b>Age:</b> 18 years		
	<b>Encapsulant</b>	<b>Backsheet</b>	<b>Metallization</b>	<b>Junction Box</b>	<b>Frame</b>
<b>Degradation Present</b>	Yes	No	Yes	No	Yes
<b>Details</b>	Light Discoloration, No Delamination	Like New	Light Corrosion	Intact & Good Seal	Minor damage & corrosion
<b>Module Soiling:</b> Lightly Soiled	<b>Shaded Area:</b> 0 -25%	<b>Maintenance:</b> Responsive	<b>End Use:</b> Light, Fan , PC		
<b>Electrical Performance:</b>					
Degradation in Pmax (% per year *)	0.79				
Degradation in Isc (% per year *)	0.60				
Degradation in Voc (% per year *)	-0.64				
* Based on I-V Curve correction using assumed values for various coefficients (alpha = 0.12% per C, beta =-0.2% per C, Rs=0 & k=0) and assuming linear rate of degradation with time.					
<b>Key Observations:</b>					
<ul style="list-style-type: none"> <li>• Light Yellow discoloration on the module</li> <li>• Corrosion on the metallization and cell interconnects</li> </ul>					
<b>Recommendations:</b>					
Modules should be cleaned at least once a week since dust on the modules can reduce the power generation.					
<b>Light Discoloration</b>		<b>Corrosion in Metallization</b>		<b>Corrosion in cell interconnects</b>	

ALL INDIA SURVEY OF PV MODULE DEGRADATION: 2013

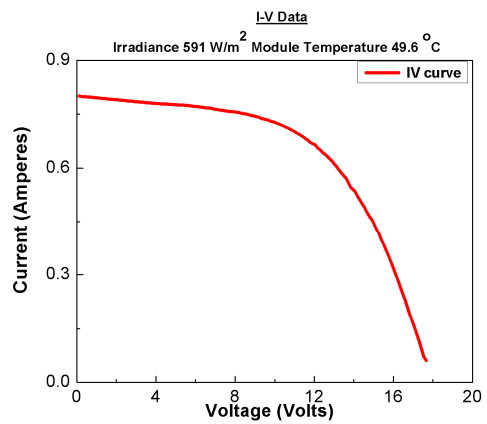
SITE-WISE DATA & ANALYSIS						
<b>Site No.:</b>	4	<b>Location:</b>	Auroville	<b>Climatic Zone:</b>	Hot & Humid	
<b>Module No.:</b>	F	<b>Type:</b>	Mono Crystalline Silicon	<b>Power Rating:</b>	40 Wp	<b>Age:</b> 18 years
<b>Degradation Present</b>	<b>Encapsulant</b>	<b>Backsheet</b>	<b>Metallization</b>	<b>Junction Box</b>	<b>Frame</b>	
	No	No	No	No	Yes	
<b>Details</b>	No Discoloration, No Delamination		Like New	Light new	Intact & Good Seal	Major damage & corrosion
<b>Module Soiling:</b>	Lightly Soiled	<b>Shaded Area:</b>	0 -25%	<b>Maintenance</b>	Responsive	<b>End Use:</b> Light, Fan , PC
<b>Electrical Performance:</b>						
Degradation in Pmax (% per year *)	1.07					
Degradation in Isc (% per year *)	-1.33					
Degradation in Voc (% per year *)	0.71					
* Based on I-V Curve correction using assumed values for various coefficients (alpha = 0.12% per C, beta =-0.2% per C, Rs=0 & k=0) and assuming linear rate of degradation with time.						
<b>Key Observations:</b>						
<ul style="list-style-type: none"> <li>The module is having glass as top cover and bottom cover both.</li> <li>There is no discoloration in the encapsulant even after 18 years of service.</li> <li>There is no corrosion of the interconnects</li> <li>The frame has suffered corrosion</li> </ul>						
<b>Recommendations:</b>						
All modules in operation should be cleaned at regular intervals (at least once a week) to prevent power loss due to dust.						
<b>No discoloration in encapsulant</b>		<b>Module backside</b>		<b>Non-standard Output Terminals</b>		
						

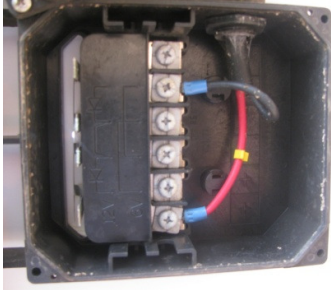

## ALL INDIA SURVEY OF PV MODULE DEGRADATION: 2013

<b>SITE-WISE DATA &amp; ANALYSIS</b>					
<b>Site No.:</b>	5	<b>Location:</b>	Auroville	<b>Climatic Zone:</b>	Hot & Humid
<b>Module No. :</b>	A	<b>Type:</b>	Mono Crystalline Silicon	<b>Power Rating:</b>	75 Wp <b>Age:</b> 18 years
<b>Degradation Present</b>	<b>Encapsulant</b> Yes	<b>Backsheet</b> No	<b>Metallization</b> Yes	<b>Junction Box</b> No	<b>Frame</b> No
<b>Details</b>	Dark Discoloration, Delamination	Like New	Dark Corrosion	Intact & Good Seal	Like new
<b>Module Soiling:</b>	Lightly Soiled	<b>Shaded Area:</b>	0 – 25%	<b>Maintenance:</b>	Responsive <b>End Use:</b> DC Water Pump
<b>Electrical Performance:</b>					
Degradation in Pmax (% per year *)	1.88				
Degradation in Isc (% per year *)	1.06				
Degradation in Voc (% per year *)	-0.17				
* Based on I-V Curve correction using assumed values for various coefficients (alpha = 0.12% per C, beta =-0.2% per C, Rs=0 & k=0) and assuming linear rate of degradation with time.					
<b>Key Observations:</b>					
<ul style="list-style-type: none"> <li>Dark discoloration on the solar cells</li> <li>Corrosion in the Metallization and interconnects</li> <li>Delamination along the solar cell periphery</li> </ul>					
<b>Recommendations:</b>					
The degraded module is placed on the same tracker in series with some of the better modules, which is not advisable. The degraded module should be replaced by a new module having same short circuit current rating as the other modules in series. Modules should be cleaned at least once a week since dust on the modules can reduce the power generation.					
<b>Modules placed on 2 Axis Tracker</b>	<b>Delamination &amp; Discoloration on cells</b>			<b>Output terminals in good condition</b>	
					

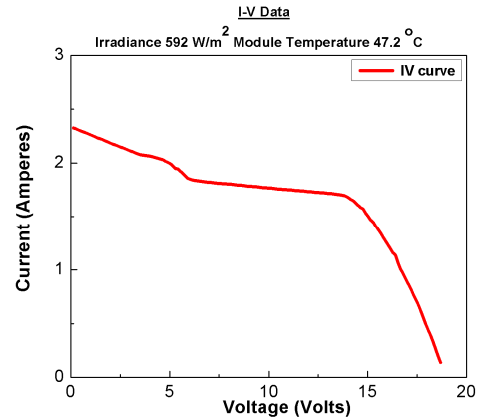

ALL INDIA SURVEY OF PV MODULE DEGRADATION: 2013

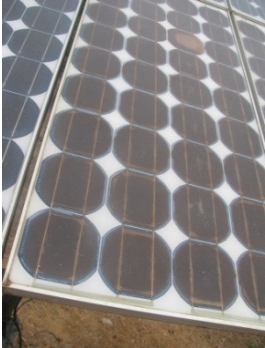
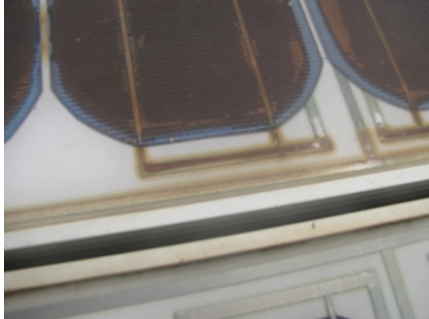
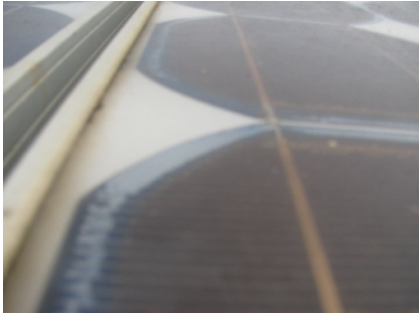

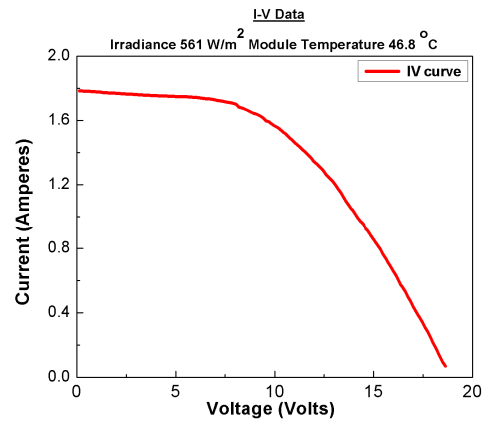
SITE-WISE DATA & ANALYSIS							
<b>Site No.:</b>	5	<b>Location:</b>	Auroville	<b>Climatic Zone:</b>	Hot & Humid		
<b>Module No. :</b>	B	<b>Type:</b>	Mono Crystalline Silicon	<b>Power Rating:</b>	75 Wp	<b>Age:</b>	18 years
<b>Degradation Present</b>	<b>Encapsulant</b>	<b>Backsheet</b>	<b>Metallization</b>	<b>Junction Box</b>	<b>Frame</b>		
	Yes	No	Yes	No	No		
<b>Details</b>	Dark Discoloration, Delamination	Like New	Dark Corrosion	Intact & Good Seal	Like new		
<b>Module Soiling:</b>	Lightly Soiled	<b>Shaded Area:</b>	0 – 25%	<b>Maintenance :</b>	Responsive	<b>End Use:</b>	DC Water Pump
<b>Electrical Performance:</b>							
Degradation in Pmax (% per year *)	2.35						
Degradation in Isc (% per year *)	1.01						
Degradation in Voc (% per year *)	-2.79						
* Based on I-V Curve correction using assumed values for various coefficients (alpha = 0.12% per C, beta =-0.2% per C, Rs=0 & k=0) and assuming linear rate of degradation with time.							
<b>Key Observations:</b>							
<ul style="list-style-type: none"> <li>• Dark discoloration on all solar cells</li> <li>• Corrosion of metallization and interconnects, delamination along cell edge</li> <li>• Glass cover has become hazy</li> </ul>							
<b>Recommendations:</b>							
The degraded module should not be placed in series with other better modules, since it will bring down the system performance. Modules should be cleaned at least once a week since dust on the modules can reduce the power generation.							
<b>Dark discoloration on all cells</b>		<b>Corrosion of metallization and interconnects, delamination along cell edge</b>			<b>Haziness in the Glass cover</b>		
							



## ALL INDIA SURVEY OF PV MODULE DEGRADATION: 2013

SITE-WISE DATA & ANALYSIS					
<b>Site No.:</b> 5	<b>Location:</b> Auroville	<b>Climatic Zone:</b> Hot & Humid			
<b>Module No. :</b> C	<b>Type:</b> Mono Crystalline Silicon	<b>Power Rating:</b> 75 Wp	<b>Age:</b> 18 years		
	<b>Encapsulant</b>	<b>Backsheet</b>	<b>Metallization</b>	<b>Junction Box</b>	<b>Frame</b>
<b>Degradation Present</b>	Yes	Yes	Yes	No	No
<b>Details</b>	Dark Discoloration, No Delamination	bubbles ,cracks	Dark Corrosion	Intact & Good Seal	Like new
<b>Module Soiling:</b>	Lightly Soiled	<b>Shaded Area:</b>	25 – 75%	<b>Maintenance:</b>	Responsive
			<b>End Use:</b>	DC Water Pump	
<b>Electrical Performance:</b>					
Degradation in Pmax (% per year *)	4.10				
Degradation in Isc (% per year *)	3.24				
Degradation in Voc (% per year *)	-3.79				
* Based on I-V Curve correction using assumed values for various coefficients (alpha = 0.12% per C, beta =-0.2% per C, Rs=0 & k=0) and assuming linear rate of degradation with time.					
<b>Key Observations:</b>					
<ul style="list-style-type: none"> <li>• Dark discoloration on all solar cells in the module</li> <li>• Uneven discoloration in some of the solar cells</li> <li>• Corrosion in the bus bars and cell interconnects</li> </ul>					
<div style="display: flex; align-items: center;"> <div style="flex: 1;"> <p style="text-align: center;"><b>I-V Data</b></p> <p style="text-align: center;">Irradiance 588 W/m<sup>2</sup> Module Temperature 49.0 °C</p> </div> <div style="flex: 0.5; text-align: center;"> <p>— IV curve</p> </div> </div>					
<b>Recommendations:</b>					
Degraded module should not be kept in series with other better performing modules as it will bring down the performance of the system. Modules should be cleaned at least once a week since dust on the modules can reduce the power generation.					
<b>Dark Discoloration</b>		<b>Uneven Discoloration in some solar cells</b>		<b>Corrosion in the busbars &amp; cell interconnects</b>	

ALL INDIA SURVEY OF PV MODULE DEGRADATION: 2013



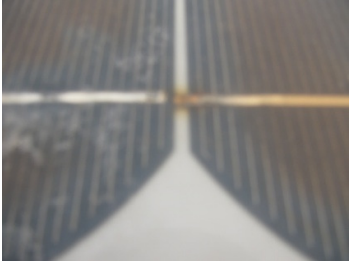
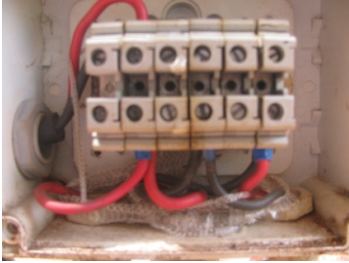

SITE-WISE DATA & ANALYSIS					
<b>Site No.:</b> 5	<b>Location:</b> Auroville S Farm Pondicherry	<b>Climatic Zone:</b> Hot & Humid			
<b>Module No. :</b> D	<b>Type:</b> Multi Crystalline Silicon	<b>Power Rating:</b> 35 Wp	<b>Age:</b> 6 years		
	<b>Encapsulant</b>	<b>Backsheet</b>	<b>Metallization</b>	<b>Junction Box</b>	<b>Frame</b>
<b>Degradation Present</b>	No	No	No	No	No
<b>Details</b>	Like new, Delamination	Like new	Like new	Intact & Good Seal	Like new
<b>Module Soiling:</b> Lightly Soiled	<b>Shaded Area:</b> 25 – 75%	<b>Maintenance:</b> Responsive	<b>End Use:</b> DC Water Pump		
<b>Electrical Performance:</b>					
Degradation in Pmax (% per year *)	-0.14				
Degradation in Isc (% per year *)	0.88				
Degradation in Voc (% per year *)	-0.34				
* Based on I-V Curve correction using assumed values for various coefficients (alpha = 0.12% per C, beta =-0.2% per C, Rs=0 & k=0) and assuming linear rate of degradation with time.					
<b>Key Observations:</b>					
<ul style="list-style-type: none"> <li>• No signs of discoloration or delamination</li> <li>• Slight corrosion in the fingers and also in terminals</li> </ul>					
<b>Recommendations:</b>					
Modules should be cleaned at least once a week since dust on the modules can reduce the power generation.					
<b>No Discoloration or delamination</b>		<b>Light Discoloration in Fingers (Metallization)</b>		<b>Corrosion in output terminals</b>	
					

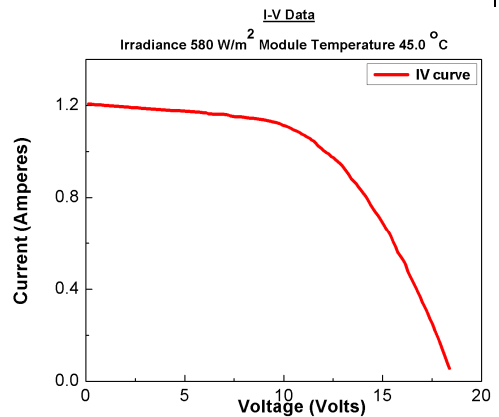
ALL INDIA SURVEY OF PV MODULE DEGRADATION: 2013

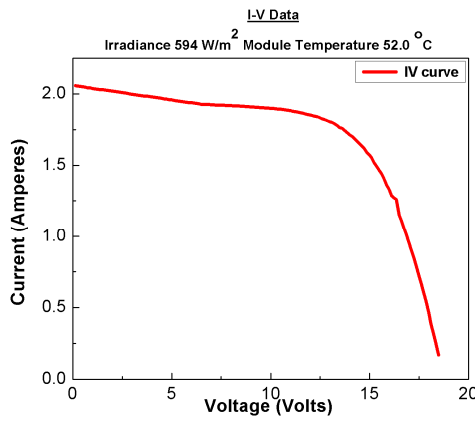

SITE-WISE DATA & ANALYSIS					
<b>Site No.:</b>	6	<b>Location:</b>	Auroville M House	<b>Climatic Zone:</b>	Hot & Humid
<b>Module No. :</b>	A	<b>Type:</b>	Mono Crystalline Silicon	<b>Power Rating:</b>	75 Wp
		<b>Age:</b>	13 years		
<b>Degradation Present</b>	<b>Encapsulant</b>	<b>Backsheet</b>	<b>Metallization</b>	<b>Junction Box</b>	<b>Frame</b>
	Yes	No	Yes	No	No
<b>Details</b>	Dark Discoloration, Delamination	Like New	Dark Corrosion	Intact & Good Seal	Like new
<b>Module Soiling:</b>	Heavily Soiled	<b>Shaded Area:</b>	25 – 75%	<b>Maintenance :</b>	Preventive
		<b>End Use:</b>	Light, fan		e
<b>Electrical Performance:</b>					
Degradation in Pmax (% per year *)	0.99				
Degradation in Isc (% per year *)	0.97				
Degradation in Voc (% per year *)	-2.70				
* Based on I-V Curve correction using assumed values for various coefficients (alpha = 0.12% per C, beta =-0.2% per C, Rs=0 & k=0) and assuming linear rate of degradation with time.					
<b>Key Observations:</b>					
<ul style="list-style-type: none"> <li>• Discoloration in all solar cells</li> <li>• Corrosion in the cell interconnects</li> <li>• Corrosion in the junction box terminals</li> </ul>					
<b>Recommendations:</b>					
Modules should be cleaned at least once a week since dust on the modules can reduce the power generation.					
<b>Yellow Discoloration</b>		<b>Corrosion in cell interconnects</b>		<b>Corrosion in the Junction Box terminals</b>	
					





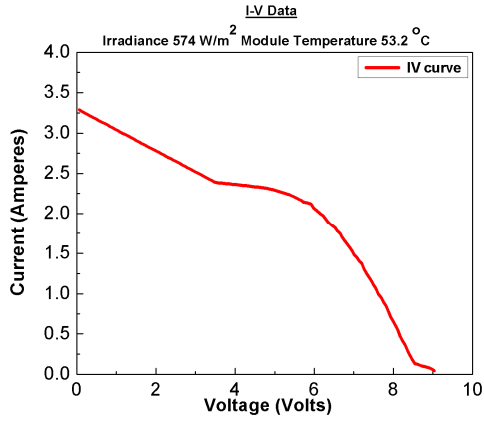

ALL INDIA SURVEY OF PV MODULE DEGRADATION: 2013

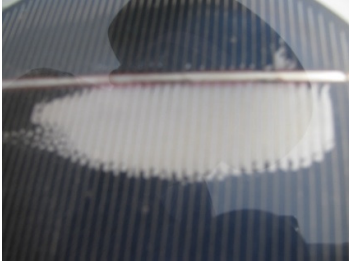
SITE-WISE DATA & ANALYSIS							
<b>Site No.:</b>	7	<b>Location:</b>	Chennai	<b>Climatic Zone:</b>	Hot & Humid		
<b>Module No.:</b>	A	<b>Type:</b>	Mono Crystalline Silicon	<b>Power Rating:</b>	75 Wp	<b>Age:</b>	16 years
	<b>Encapsulant</b>	<b>Backsheet</b>	<b>Metallization</b>	<b>Junction Box</b>	<b>Frame</b>		
<b>Degradation Present</b>	Yes	No	Yes	No	Yes		
<b>Details</b>	Dark Discoloration, Delamination	Like New	Light Corrosion	Intact & Good Seal	Minor damage & corrosion		
<b>Module Soiling:</b>	Lightly Soiled	<b>Shaded Area:</b>	0 – 25 %	<b>Maintenance:</b>	Responsive	<b>End Use:</b>	Light, Fan
<b>Electrical Performance:</b>							
Degradation in Pmax (% per year *)		-0.70					
Degradation in Isc (% per year *)		0.18					
Degradation in Voc (% per year *)		-0.34					
* Based on I-V Curve correction using assumed values for various coefficients (alpha = 0.12% per C, beta = -0.2% per C, Rs=0 & k=0) and assuming linear rate of degradation with time.							
<b>Key Observations:</b>							
<ul style="list-style-type: none"> <li>• Dark discoloration in most of the solar cells</li> <li>• Delamination near the busbars and also elsewhere on top of the solar cells</li> </ul>							
<b>Recommendations:</b>							
Tilt Angle should be rectified to get higher energy generation. Modules should be cleaned at least once a week since dust on the modules can reduce the power generation.							
<b>Discoloration in majority of cells</b>		<b>Delamination and discoloration on cell, Corrosion on metallization</b>			<b>Delamination near busbars</b>		
							

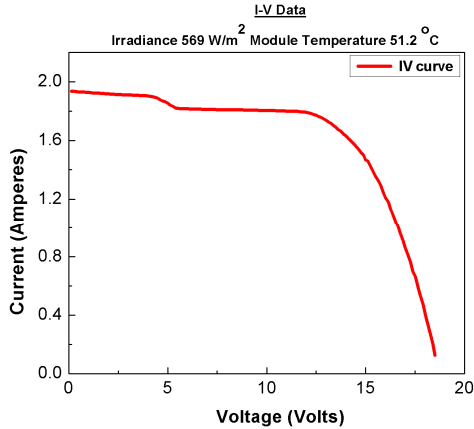

## ALL INDIA SURVEY OF PV MODULE DEGRADATION: 2013

<b>SITE-WISE DATA &amp; ANALYSIS</b>						
<b>Site No.:</b>	7	<b>Location:</b>	Chennai	<b>Climatic Zone:</b>	Hot & Humid	
<b>Module No. :</b>	B	<b>Type:</b>	Mono Crystalline Silicon	<b>Power Rating:</b>	75 Wp	<b>Age:</b> 16 years
	<b>Encapsulant</b>	<b>Backsheet</b>	<b>Metallization</b>	<b>Junction Box</b>	<b>Frame</b>	
<b>Degradation Present</b>	Yes	No	Yes	No	Yes	
<b>Details</b>	Light Discoloration, Delamination	Like New	Light Corrosion	Intact & Good Seal	Minor damage & corrosion	
<b>Module Soiling:</b>	Lightly Soiled	<b>Shaded Area:</b>	0 – 25 %	<b>Maintenance:</b>	Responsive	<b>End Use:</b> Light, Fan
<b>Electrical Performance:</b>						
Degradation in Pmax (% per year *)	3.95					
Degradation in Isc (% per year *)	2.40					
Degradation in Voc (% per year *)	-1.04					
* Based on I-V Curve correction using assumed values for various coefficients (alpha = 0.12% per C, beta = -0.2% per C, Rs=0 & k=0) and assuming linear rate of degradation with time.						
<b>Key Observations:</b>						
<ul style="list-style-type: none"> <li>Discoloration on some of the solar cells</li> <li>Major Delamination on a few of the solar cells</li> <li>Delamination along the diagonal of a solar cell along with change in colour may be due to a crack in the cell</li> <li>Tilt angle of modules is 23 degrees while the latitude of the place is 13 degrees, so the modules are placed at a non-optimum tilt</li> </ul>						
<b>Recommendations:</b>						
Modules should be cleaned at least once a week since dust on the modules can reduce the power generation. The tilt angle should be equal to the Latitude angle for maximizing the annual energy generation.						
<div style="text-align: center;">  </div>						
<b>Discoloration on some solar cells</b>			<b>Delamination along a diagonal</b>		<b>Major delamination on a solar cell</b>	
						





## ALL INDIA SURVEY OF PV MODULE DEGRADATION: 2013

<b>SITE-WISE DATA &amp; ANALYSIS</b>					
<b>Site No.:</b>	7	<b>Location:</b>	Chennai	<b>Climatic Zone:</b>	Hot & Humid
<b>Module No. :</b>	C	<b>Type:</b>	Mono Crystalline Silicon	<b>Power Rating:</b>	75 Wp <b>Age:</b> 16 years
	<b>Encapsulant</b>	<b>Backsheet</b>	<b>Metallization</b>	<b>Junction Box</b>	<b>Frame</b>
<b>Degradation Present</b>	Yes	No	Yes	No	Yes
<b>Details</b>	Light Discoloration, Delamination	Like New	Minor Corrosion	Intact & Good Seal	Minor damage & corrosion
<b>Module Soiling:</b>	Lightly Soiled	<b>Shaded Area:</b>	0 – 25 %	<b>Maintenance:</b>	Responsive <b>End Use:</b> Light, Fan
<b>Electrical Performance:</b>					
Degradation in Pmax (% per year *)		0.31			
Degradation in Isc (% per year *)		0.29			
Degradation in Voc (% per year *)		-0.22			
* Based on I-V Curve correction using assumed values for various coefficients (alpha = 0.12% per C, beta = -0.2% per C, Rs=0 & k=0) and assuming linear rate of degradation with time.					
<b>Key Observations:</b>					
<ul style="list-style-type: none"> <li>Light discoloration in some of the solar cells</li> <li>Minor delamination in 1 cell</li> <li>Minor corrosion in the frame</li> <li>Glass has become yellowish at the edges due to dust deposition</li> <li>Corrosion in the output terminals</li> <li>The tilt angle of the modules is close to the latitude angle at the site.</li> </ul>					
					
<b>Recommendations:</b>					
Modules should be cleaned at least once a week since dust on the modules can reduce the power generation.					
<b>Light Discoloration in some cells</b>		<b>Corrosion in the frame and dust deposits on the Glass at the corner</b>		<b>Corrosion in the output terminals</b>	
					

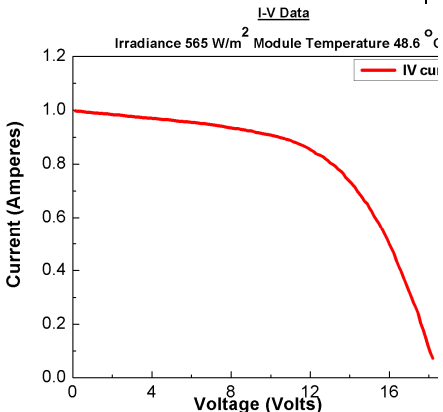

## ALL INDIA SURVEY OF PV MODULE DEGRADATION: 2013

<b>SITE-WISE DATA &amp; ANALYSIS</b>					
<b>Site No.:</b>	7	<b>Location:</b>	Chennai	<b>Climatic Zone:</b>	Hot & Humid
<b>Module No. :</b>	D	<b>Type:</b>	Mono Crystalline Silicon	<b>Power Rating:</b>	35 Wp
		<b>Age:</b>			16 years
	<b>Encapsulant</b>	<b>Backsheet</b>	<b>Metallization</b>	<b>Junction Box</b>	<b>Frame</b>
<b>Degradation Present</b>	Yes	No	Yes	Yes	Yes
<b>Details</b>	Light Discoloration, Delamination	Like New	Dark Corrosion	Fell off	Minor damage & corrosion
<b>Module Soiling:</b>	Lightly Soiled	<b>Shaded Area:</b>	0 – 25%	<b>Maintenance:</b>	Responsive
		<b>End Use:</b>			Light, fan
<b>Electrical Performance:</b>					
Degradation in Pmax (% per year *)	1.18				
Degradation in Isc (% per year *)	1.14				
Degradation in Voc (% per year *)	0.02				
* Based on I-V Curve correction using assumed values for various coefficients (alpha = 0.12% per C, beta = -0.2% per C, Rs=0 & k=0) and assuming linear rate of degradation with time.					
<b>Key Observations:</b>					
<ul style="list-style-type: none"> <li>Discoloration in most of the solar cells</li> <li>Corrosion in the bus bars and cell interconnects</li> <li>Delamination in some of the cells</li> <li>Hard-to-remove dust deposits on the glass</li> <li>The tilt angle of the modules is close to the latitude angle at the site</li> </ul>					
<div style="display: flex; align-items: center;"> <div style="flex: 1;"> <p style="text-align: center; margin: 0;"><b>I-V Data</b></p> <p style="text-align: center; margin: 0;">Irradiance 588 W/m<sup>2</sup>    Module Temperature 48.9 °C</p> </div> <div style="flex: 0 0 100px; text-align: center;"> <p style="font-size: small;">IV curve</p> </div> </div>					
<b>Recommendations:</b>					
Modules should be cleaned at least once a week since dust on the modules can reduce the power generation.					
<b>Discoloration in most of the cells</b>		<b>Corrosion in Metallization, and delamination</b>		<b>Dust</b>	
					

## ALL INDIA SURVEY OF PV MODULE DEGRADATION: 2013



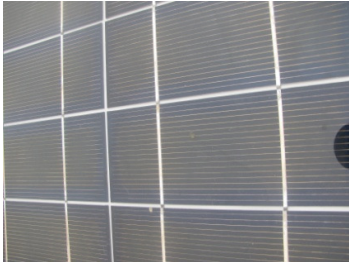

<b>SITE-WISE DATA &amp; ANALYSIS</b>					
<b>Site No.:</b> 7	<b>Location:</b> Chennai	<b>Climatic Zone:</b> Hot & Humid			
<b>Module No. :</b> E	<b>Type:</b> Mono Crystalline Silicon	<b>Power Rating:</b> 35 Wp	<b>Age:</b> 5 years		
	<b>Encapsulant</b>	<b>Backsheet</b>	<b>Metallization</b>	<b>Junction Box</b>	<b>Frame</b>
<b>Degradation Present</b>	Yes	No	Yes	Yes	Yes
<b>Details</b>	Light Discoloration, Delamination	Like New	Corrosion	Fell off	Minor damage & corrosion
<b>Module Soiling:</b> Lightly Soiled	<b>Shaded Area:</b> 0 – 25%	<b>Maintenance:</b> Responsive	<b>End Use:</b> Light, fan		
<b>Electrical Performance:</b>					
Degradation in Pmax (% per year *)	1.67				
Degradation in Isc (% per year *)	1.16				
Degradation in Voc (% per year *)	-0.46				
* Based on I-V Curve correction using assumed values for various coefficients (alpha = 0.12% per C, beta = -0.2% per C, Rs=0 & k=0) and assuming linear rate of degradation with time.					
<b>Key Observations:</b>					
<ul style="list-style-type: none"> <li>Discoloration and delamination in all the solar cells</li> <li>Minor corrosion in some sections of the metallization</li> <li>Chalking (white powder) from the backsheet</li> <li>Tilt angle of Module is 40 deg. whereas Latitude is 13 deg.</li> <li>(Non-optimum tilt)</li> </ul>					
					
<b>Recommendations:</b>					
Modules should be cleaned at least once a week since dust on the modules can reduce the power generation. The Tilt angle should be adjusted close to the Latitude angle to increase the annual energy generation.					
<b>Degradation visible in all the cells</b>		<b>Discoloration and delamination</b>		<b>White powder from backsheet</b>	
					

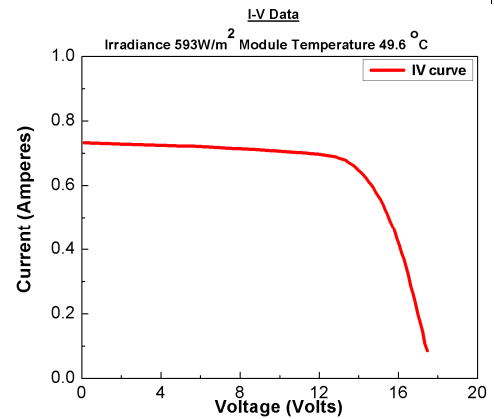
## ALL INDIA SURVEY OF PV MODULE DEGRADATION: 2013

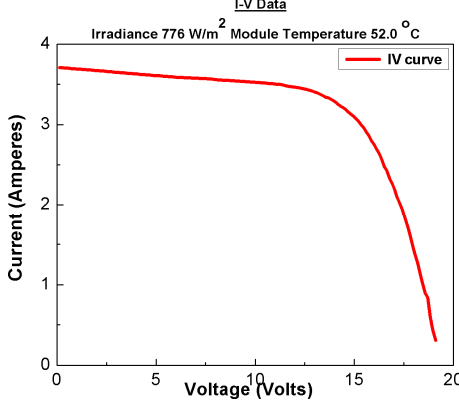

<b>SITE-WISE DATA &amp; ANALYSIS</b>					
<b>Site No.:</b>	7	<b>Location:</b>	Chennai	<b>Climatic Zone:</b>	Hot & Humid
<b>Module No. :</b>	F	<b>Type:</b>	Mono Crystalline Silicon	<b>Power Rating:</b>	40 Wp <b>Age:</b> 5 years
	<b>Encapsulant</b>	<b>Backsheet</b>	<b>Metallization</b>	<b>Junction Box</b>	<b>Frame</b>
<b>Degradation Present</b>	Yes	No	Yes	No	No
<b>Details</b>	Light Discoloration, Delamination	Like New	Light Corrosion	Loose and brittle	Like new
<b>Module Soiling:</b>	Lightly Soiled	<b>Shaded Area:</b>	0 – 25%	<b>Maintenance:</b>	Responsive <b>End Use:</b> Light, fan
<b>Electrical Performance:</b>					
Degradation in Pmax (% per year *)	-0.42				
Degradation in Isc (% per year *)	0.78				
Degradation in Voc (% per year *)	-4.77				
* Based on I-V Curve correction using assumed values for various coefficients (alpha = 0.12% per C, beta =-0.2% per C, Rs=0 & k=0) and assuming linear rate of degradation with time.					
<b>Key Observations:</b>					
<ul style="list-style-type: none"> <li>Light discoloration but no delamination</li> <li>Minor corrosion in the Metallization (fingers)</li> <li>Corrosion in the output terminals</li> <li>Tilt angle of Module is 40 deg. whereas Latitude is 13 deg.</li> <li>(Non-optimum tilt)</li> </ul>					
<b>Recommendations:</b>					
Modules should be cleaned at least once a week since dust on the modules can reduce the power generation. The Tilt angle should be adjusted close to the Latitude angle to increase the annual energy generation.					
<b>Light Discoloration</b>		<b>Minor Corrosion of fingers</b>		<b>Corrosion of the output terminals</b>	
					

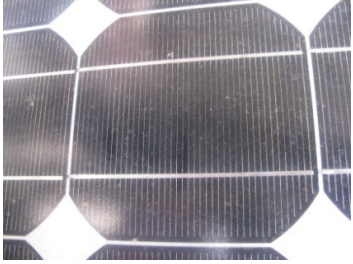

## ALL INDIA SURVEY OF PV MODULE DEGRADATION: 2013

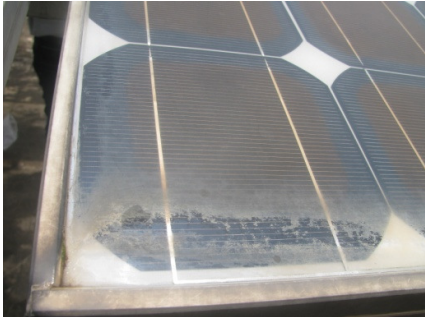

<b>SITE-WISE DATA &amp; ANALYSIS</b>							
<b>Site No.:</b>	7	<b>Location:</b>	Chennai	<b>Climatic Zone:</b>	Hot & Humid		
<b>Module No. :</b>	G	<b>Type:</b>	Mono Crystalline Silicon	<b>Power Rating:</b>	75 Wp	<b>Age:</b>	8 years
		<b>Encapsulant</b>	<b>Backsheet</b>	<b>Metallization</b>	<b>Junction Box</b>	<b>Frame</b>	
<b>Degradation Present</b>		Yes	No	Yes	No	Yes	
<b>Details</b>		Light Discoloration	Like New	Minor Corrosion	Intact & Good Seal	Minor damage & corrosion	
<b>Module Soiling:</b>	Lightly Soiled	<b>Shaded Area:</b>	0 – 25%	<b>Maintenance:</b>	Responsive	<b>End Use:</b>	Light, fan
<b>Electrical Performance:</b>				<div style="display: flex; justify-content: space-between;"> <div> <p><b>I-V Data</b></p> <p>Irradiance 776 W/m<sup>2</sup> Module Temperature 52.0 °C</p>  </div> <div style="text-align: right;"> <p>— IV curve</p> </div> </div>			
Degradation in Pmax (% per year *)	1.40						
Degradation in Isc (% per year *)	0.72						
Degradation in Voc (% per year *)	-0.26						
<p>* Based on I-V Curve correction using assumed values for various coefficients (alpha = 0.12% per C, beta = -0.2% per C, Rs=0 &amp; k=0) and assuming linear rate of degradation with time.</p>							
<b>Key Observations:</b>							
<ul style="list-style-type: none"> <li>Light discoloration</li> <li>Discoloration on the Metallization (fingers)</li> <li>Output terminals have corroded</li> </ul>							
<b>Recommendations:</b>							
Modules should be cleaned at least once a week since dust on the modules can reduce the power generation.							
<b>Light Discoloration in most of the cells</b>			<b>Discoloration on Fingers</b>		<b>Corrosion of output terminals</b>		
							

## ALL INDIA SURVEY OF PV MODULE DEGRADATION: 2013

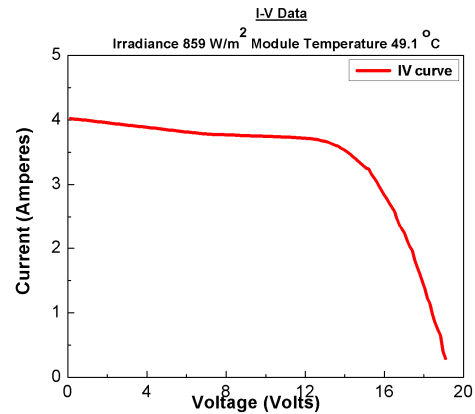
<b>SITE-WISE DATA &amp; ANALYSIS</b>					
<b>Site No.:</b>	8	<b>Location:</b>	Bangalore	<b>Climatic Zone:</b>	Temperate
<b>Module No. :</b>	A	<b>Type:</b>	Mono Crystalline Silicon	<b>Power Rating:</b>	75 Wp
		<b>Age:</b>			15 years
<b>Degradation Present</b>	<b>Encapsulant</b>	<b>Backsheet</b>	<b>Metallization</b>	<b>Junction Box</b>	<b>Frame</b>
	Yes	No	Yes	No	Yes
<b>Details</b>	Light Discoloration, Delamination	Like New	Light Corrosion	Intact & Good Seal	Minor damage & corrosion
<b>Module Soiling:</b>	Heavily Soiled	<b>Shaded Area:</b>	0 – 25%	<b>Maintenance:</b>	Preventive
		<b>End Use:</b>			DC Water Pump
<b>Electrical Performance:</b>					
Degradation in Pmax (% per year *)	1.13				
Degradation in Isc (% per year *)	0.61				
Degradation in Voc (% per year *)	0.26				
* Based on I-V Curve correction using assumed values for various coefficients (alpha = 0.12% per C, beta = -0.2% per C, Rs=0 & k=0) and assuming linear rate of degradation with time.					
<b>Key Observations:</b>					
<ul style="list-style-type: none"> <li>Discoloration is visible in the middle portion of all the solar cells</li> <li>Discoloration on the Metallization (fingers)</li> <li>A hard patch of dust can be seen near the bottom edge of the module</li> <li>Tilt angle of Module closely matches the latitude angle of the site, so the annual power generation will be maximum.</li> </ul>					
<b>Recommendations:</b>					
Modules should be cleaned at least once a week since dust on the modules can reduce the power generation.					
<b>Discoloration on all cells</b>		<b>Glass has become hazy</b>		<b>Hard-to-remove dust deposits on the Glass</b>	
					





## ALL INDIA SURVEY OF PV MODULE DEGRADATION: 2013

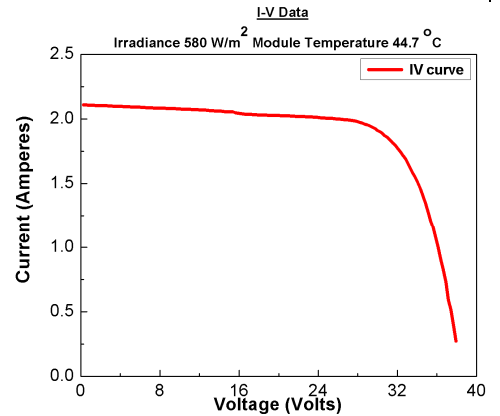

SITE-WISE DATA & ANALYSIS					
<b>Site No.:</b>	9	<b>Location:</b>	Bangalore	<b>Climatic Zone:</b>	Temperate
<b>Module No. :</b>	A	<b>Type:</b>	Multi Crystalline Silicon	<b>Power Rating:</b>	170 Wp
		<b>Age:</b>	5 years		
	<b>Encapsulant</b>	<b>Backsheet</b>	<b>Metallization</b>	<b>Junction Box</b>	<b>Frame</b>
<b>Degradation Present</b>	No	No	No	No	Yes
<b>Details</b>	Like new	Like New	Like New	Intact & Good Seal	Minor Corrosion
<b>Module Soiling:</b>	Lightly Soiled	<b>Shaded Area:</b>	0 – 25%	<b>Maintenance:</b>	Preventive
		<b>End Use:</b>	Light, fan		
<b>Electrical Performance:</b>					
Degradation in Pmax (% per year *)	-0.84				
Degradation in Isc (% per year *)	-1.29				
Degradation in Voc (% per year *)	-0.17				
* Based on I-V Curve correction using assumed values for various coefficients (alpha = 0.12% per C, beta = -0.2% per C, Rs=0 & k=0) and assuming linear rate of degradation with time.					
<b>Key Observations:</b>					
<ul style="list-style-type: none"> <li>• All except the frame are in good condition</li> <li>• Frame has suffered minor corrosion</li> <li>• A thin film of dust has stuck to the front glass and is proving difficult to remove.</li> <li>• Tilt angle of Module closely matches the latitude at the site, which will produce the maximum annual energy.</li> </ul>					
<b>Recommendations:</b>					
Modules should be cleaned at least once a week since dust on the modules can reduce the power generation.					
<b>Light dust deposition on the module</b>		<b>Thin layer of hard-to-remove dust deposits near the bottom edge</b>		<b>Minor corrosion in the frame</b>	
					

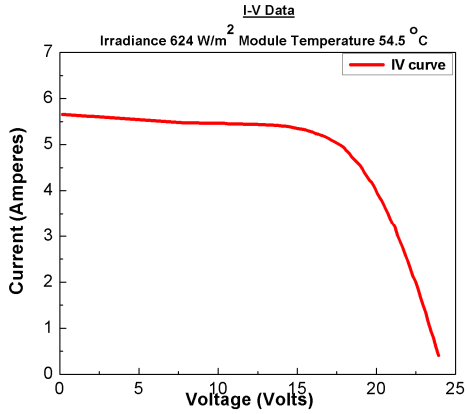

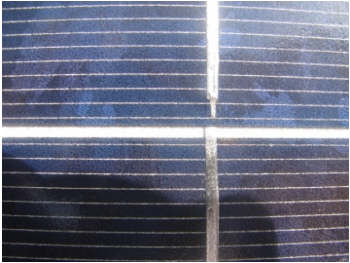
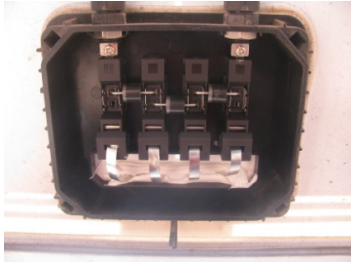
## ALL INDIA SURVEY OF PV MODULE DEGRADATION: 2013

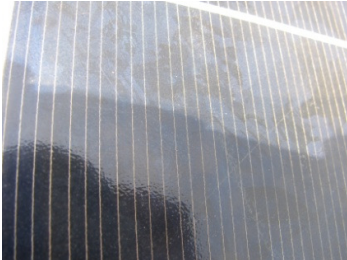

SITE-WISE DATA & ANALYSIS					
<b>Site No.:</b>	10	<b>Location:</b>	Pune	<b>Climatic Zone:</b>	Hot & Humid
<b>Module No. :</b>	A	<b>Type:</b>	Multi Crystalline Silicon	<b>Power Rating:</b>	170 Wp <b>Age:</b> 3 years
<b>Degradation Present</b>	Encapsulant: No	Backsheet: No	Metallization: No	Junction Box: No	Frame: No
<b>Details</b>	Like new	Like New	Like New	Intact & Good Seal	Like New
<b>Module Soiling:</b>	Heavily Soiled	<b>Shaded Area:</b>	0 – 25 %	<b>Maintenance:</b>	Preventive <b>End Use:</b> Light, fan
<b>Electrical Performance:</b>					
Degradation in Pmax (% per year *)	2.60				
Degradation in Isc (% per year *)	1.99				
Degradation in Voc (% per year *)	1.72				
* Based on I-V Curve correction using assumed values for various coefficients (alpha = 0.12% per C, beta =-0.2% per C, Rs=0 & k=0) and assuming linear rate of degradation with time.					
<b>Key Observations:</b>					
<ul style="list-style-type: none"> <li>• There is no discoloration (browning) or delamination.</li> <li>• The solar cells have small dark spots spread all over the surface.</li> <li>• The modules are heavily soiled</li> </ul>					
					
<b>Recommendations:</b>					
Modules should be cleaned at least once a week since dust on the modules can reduce the power generation.					
<b>Heavy soiling evident from the contrast</b>		<b>Small dark spots spread all the solar cells</b>		<b>Output terminals in good condition</b>	
					

## ALL INDIA SURVEY OF PV MODULE DEGRADATION: 2013

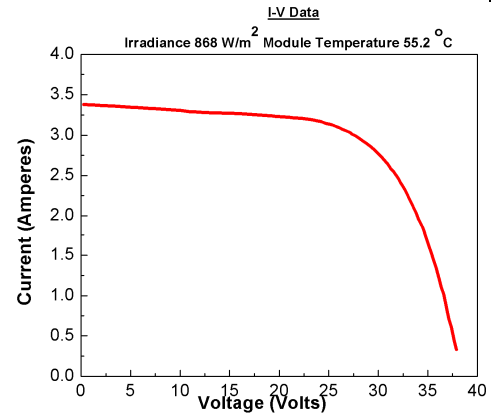
SITE-WISE DATA & ANALYSIS						
<b>Site No.:</b>	11	<b>Location:</b>	Pune	<b>Climatic Zone:</b>	Hot & Humid	
<b>Module No. :</b>	A	<b>Type:</b>	Multi Crystalline Silicon	<b>Power Rating:</b>	120 Wp	<b>Age:</b> 4 years
		<b>Encapsulant</b>	<b>Backsheet</b>	<b>Metallization</b>	<b>Junction Box</b>	<b>Frame</b>
<b>Degradation Present</b>		No	No	No	No	No
<b>Details</b>		Like New	Like New	Like New	Intact & Good Seal	Like New
<b>Module Soiling:</b>	Heavily Soiled	<b>Shaded Area:</b>	0 – 25 %	<b>Maintenance:</b>	Preventive	<b>End Use:</b> Light, fan
<b>Electrical Performance:</b>						
Degradation in Pmax (% per year *)			3.83			
Degradation in Isc (% per year *)			1.99			
Degradation in Voc (% per year *)			-0.59			
* Based on I-V Curve correction using assumed values for various coefficients (alpha = 0.12% per C, beta = -0.2% per C, Rs=0 & k=0) and assuming linear rate of degradation with time.						
<b>Key Observations:</b>						
<ul style="list-style-type: none"> <li>• There is no discoloration or delamination in the module.</li> <li>• The glass appears to be slightly hazy.</li> <li>• The module supporting structure is corroded.</li> <li>• Tilt angle of Module is very close to the Latitude angle.</li> </ul>						
<b>Recommendations:</b>						
Modules should be cleaned at least once a week since dust on the modules can reduce the power generation						
<b>Yellow Discoloration</b>		<b>Haziness in the glass</b>		<b>Corrosion in Module supporting structure</b>		
						





## ALL INDIA SURVEY OF PV MODULE DEGRADATION: 2013

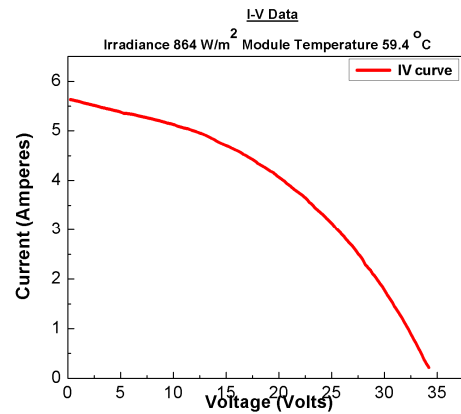

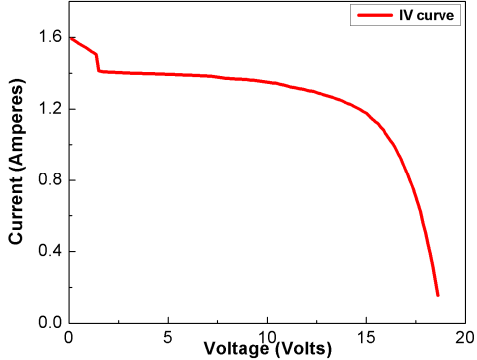
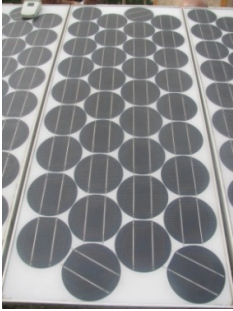
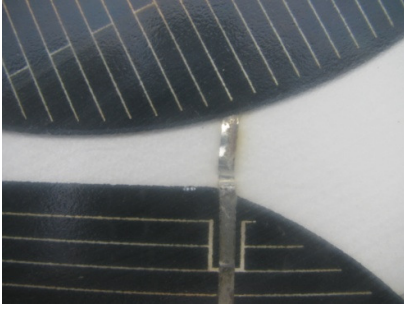

<b>SITE-WISE DATA &amp; ANALYSIS</b>					
<b>Site No.:</b>	12	<b>Location:</b>	Pune	<b>Climatic Zone:</b>	Hot & Humid
<b>Module No. :</b>	A	<b>Type:</b>	CIGS	<b>Power Rating:</b>	144 Wp <b>Age:</b> 4 years
	<b>Encapsulant</b>	<b>Backsheet</b>	<b>Metallization</b>	<b>Junction Box</b>	<b>Frame</b>
<b>Degradation Present</b>	Yes	No	No	No	No
<b>Details</b>	Light Discoloration, No Delamination	Like New	Like new	Intact & Good Seal	Like new
<b>Module Soiling:</b>	Lightly Soiled	<b>Shaded Area:</b>	0 – 25 %	<b>Maintenance:</b>	Preventive <b>End Use:</b> Light , Fan
<b>Electrical Performance:</b>					
Degradation in Pmax (% per year *)	4.68				
Degradation in Isc (% per year *)	1.02				
Degradation in Voc (% per year *)	0.72				
* Based on I-V Curve correction using assumed values for various coefficients (alpha = 0.12% per C, beta =-0.2% per C, Rs=0 & k=0) and assuming linear rate of degradation with time.					
<b>Key Observations:</b>					
<ul style="list-style-type: none"> <li>Light discoloration in 1 cell of the module but no delamination</li> <li>Small amount of dust has deposited at the corners of the module and could not be removed by wiping with dry cloth.</li> <li>Tilt angle of Module is very close to the Latitude angle, so annual generation will be maximized.</li> </ul>					
<b>Recommendations:</b>					
Tilt Angle should be rectified and nearby trees to be pruned to get higher energy generation and longer module life.					
<b>Multiple modules connected in string</b>	<b>Light yellow discoloration in some cells</b>	<b>Dust deposition at the corners of the modules</b>			
					





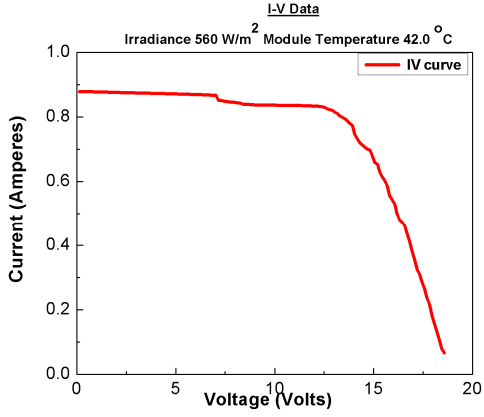

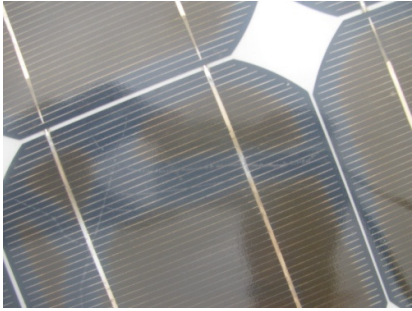
## ALL INDIA SURVEY OF PV MODULE DEGRADATION: 2013

<b>SITE-WISE DATA &amp; ANALYSIS</b>						
<b>Site No.:</b>	13	<b>Location:</b>	Sagar Island	<b>Climatic Zone:</b>	Hot & Humid	
<b>Module No. :</b>	A	<b>Type:</b>	Mono Crystalline Silicon	<b>Power Rating:</b>	75 Wp	<b>Age:</b> 15 years
	<b>Encapsulant</b>	<b>Backsheet</b>	<b>Metallization</b>	<b>Junction Box</b>	<b>Frame</b>	
<b>Degradation Present</b>	Yes	No	Yes	No	No	
<b>Details</b>	Dark Discoloration	Like New	Light Corrosion	Intact & Good Seal	Like New	
<b>Module Soiling:</b>	Lightly Soiled	<b>Shaded Area:</b>	0 %	<b>Maintenance:</b>	Preventive	<b>End Use:</b> Local AC Grid
<b>Electrical Performance:</b>						
Degradation in Pmax (% per year *)	-2.38					
Degradation in Isc (% per year *)	-1.89					
Degradation in Voc (% per year *)	-1.28					
* Based on I-V Curve correction using assumed values for various coefficients (alpha = 0.12% per C, beta = -0.2% per C, Rs=0 & k=0) and assuming linear rate of degradation with time.						
<b>Key Observations:</b>						
<ul style="list-style-type: none"> <li>Dark discoloration in the centre of each cell.</li> <li>Minor corrosion in the cell interconnects</li> <li>Chalking of the backsheet of the module</li> </ul>						
				<div style="text-align: right; font-size: small;">I-V Data</div> <div style="text-align: right; font-size: x-small;">Irradiance 590 W/m<sup>2</sup> Module Temperature 44.0 °C</div> 		
<b>Recommendations:</b>						
Modules should be cleaned at least once a week since dust on the modules can reduce the power generation. Module should be handled with care during installation so as to prevent any scratches or puncture in the modules. Module junction boxes should be properly covered to prevent moisture ingress (which can corrode the output terminals) and the cables should be regularly checked for any breakage, animal bites etc.						
<b>Dark Discoloration</b>		<b>Minor corrosion in the cell interconnects</b>			<b>Chalking of the backsheet</b>	
						

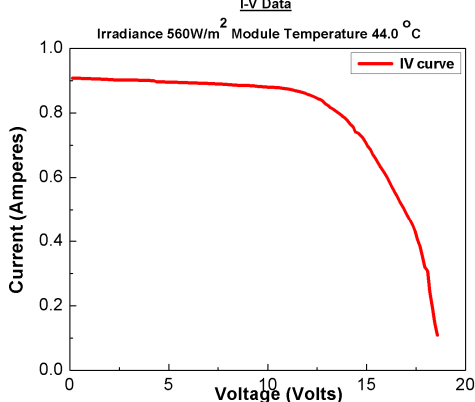

## ALL INDIA SURVEY OF PV MODULE DEGRADATION: 2013

SITE-WISE DATA & ANALYSIS					
<b>Site No.:</b> 13	<b>Location:</b> Sagar Island	<b>Climatic Zone:</b> Hot & Humid			
<b>Module No. :</b> B	<b>Type:</b> Mono Crystalline Silicon	<b>Power Rating:</b> 75 Wp	<b>Age:</b> 15 years		
	<b>Encapsulant</b>	<b>Backsheet</b>	<b>Metallization</b>	<b>Junction Box</b>	<b>Frame</b>
<b>Degradation Present</b>	Yes	No	Yes	No	No
<b>Details</b>	Dark Discoloration, Delamination	Like New	Light Corrosion	Intact & Good Seal	Like New
<b>Module Soiling:</b>	Lightly Soiled	<b>Shaded Area:</b>	0 %	<b>Maintenance:</b>	Preventive
			<b>End Use:</b>	Local AC Grid	
<b>Electrical Performance:</b>					
Degradation in Pmax (% per year *)	0.38				
Degradation in Isc (% per year *)	0.73				
Degradation in Voc (% per year *)	-7.92				
* Based on I-V Curve correction using assumed values for various coefficients (alpha = 0.12% per C, beta = -0.2% per C, Rs=0 & k=0) and assuming linear rate of degradation with time.					
<b>Key Observations:</b>					
<ul style="list-style-type: none"> <li>• Dark discoloration.</li> <li>• Cracks in cell revealed by discoloration</li> <li>• Heavy corrosion in output terminals</li> </ul>					
					
<b>Recommendations:</b>					
Junction box should be properly covered so that moisture ingress is prevented (which is corroding the terminals and causing reduction in FF and eventually result in power loss). Modules should be cleaned at least once a week since dust on the modules can reduce the power generation.					
<b>Dark discoloration in all Solar cells</b>		<b>Cracks in the Solar cell revealed by discoloration</b>		<b>Corrosion in output terminals</b>	
					

ALL INDIA SURVEY OF PV MODULE DEGRADATION: 2013

SITE-WISE DATA & ANALYSIS							
<b>Site No.:</b>	13	<b>Location:</b>	Sagar Island	<b>Climatic Zone:</b>	Hot & Humid		
<b>Module No. :</b>	C	<b>Type:</b>	Mono Crystalline Silicon	<b>Power Rating:</b>	75 Wp	<b>Age:</b>	15 years
<b>Degradation Present</b>	<b>Encapsulant</b>	<b>Backsheet</b>	<b>Metallization</b>	<b>Junction Box</b>	<b>Frame</b>		
	No	No	Yes	No	No		
<b>Details</b>	No Discoloration, No Delamination	Like New	Light Corrosion	Intact & Good Seal	Like New		
<b>Module Soiling:</b>	Lightly Soiled	<b>Shaded Area:</b>	0 %	<b>Maintenance:</b>	Preventive	<b>End Use:</b>	Local AC Grid
<b>Electrical Performance:</b>				<div style="text-align: right;">I-V Data</div> <div style="text-align: center;">Irradiance 560W/m<sup>2</sup> Module Temperature 44.0 °C</div> 			
Degradation in Pmax (% per year *)	0.05						
Degradation in Isc (% per year *)	0.62						
Degradation in Voc (% per year *)	-2.19						
* Based on I-V Curve correction using assumed values for various coefficients (alpha = 0.12% per C, beta = -0.2% per C, Rs=0 & k=0) and assuming linear rate of degradation with time.							
<b>Key Observations:</b>							
<ul style="list-style-type: none"> <li>• No discoloration and delamination in cell</li> <li>• Corrosion in the bus bar (green)</li> <li>• Heavy corrosion in output terminals.</li> <li>• Front glass broken.</li> </ul>							
<b>Recommendations:</b>							
It is safety hazard to use a module with broken glass. Modules should be cleaned at least once a week since dust on the modules can reduce the power generation.							
<b>Module with front glass shattered</b>		<b>Corrosion in the busbar (green)</b>		<b>Corrosion in output terminals</b>			
							

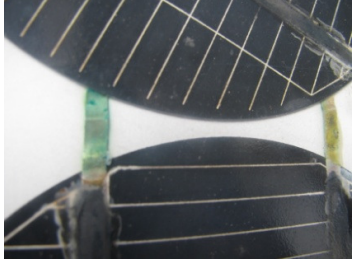
## ALL INDIA SURVEY OF PV MODULE DEGRADATION: 2013

<b>SITE-WISE DATA &amp; ANALYSIS</b>						
<b>Site No.:</b>	14	<b>Location:</b>	Sager Island Village	<b>Climatic Zone:</b>	Hot & Humid	
<b>Module No. :</b>	A	<b>Type:</b>	Mono Crystalline Silicon	<b>Power Rating:</b>	35 Wp	<b>Age:</b> 17 years
		<b>Encapsulant</b>	<b>Backsheet</b>	<b>Metallization</b>	<b>Junction Box</b>	<b>Frame</b>
<b>Degradation Present</b>		No	Yes	Yes	No	Yes
<b>Details</b>		No Discoloration, No Delamination	Bulging out under cell	Major Corrosion	Intact & Good Seal	Damaged, frame bent
<b>Module Soiling:</b>	Lightly Soiled	<b>Shaded Area:</b>	0 – 25 %	<b>Maintenance:</b>	Responsive	<b>End Use:</b> Light, fan
<b>Electrical Performance:</b>						
Degradation in Pmax (% per year *)	1.17					
Degradation in Isc (% per year *)	0.96					
Degradation in Voc (% per year *)	-3.6					
* Based on I-V Curve correction using assumed values for various coefficients (alpha = 0.12% per C, beta = -0.2% per C, Rs=0 & k=0) and assuming linear rate of degradation with time.						
<b>Key Observations:</b>						
<ul style="list-style-type: none"> <li>• No and delamination in cell</li> <li>• Corrosion in the Metallization (bus bars)</li> <li>• Green discoloration on bus bars.</li> <li>• Corrosion on output terminals.</li> </ul>						
<div style="display: flex; align-items: center;"> <div style="flex: 1;"> <p><b>I-V Data</b></p> <p>Irradiance 570 W/m<sup>2</sup> Module Temperature 48.0 °C</p> </div> <div style="flex: 0.5; text-align: center;"> <p>— IV curve</p> </div> </div>						
<b>Recommendations:</b>						
Modules should be cleaned at least once a week since dust on the modules can reduce the power generation.						
<b>No Discoloration or delamination</b>		<b>Corrosion in cell interconnects</b>		<b>Corrosion in output terminals</b>		
						

ALL INDIA SURVEY OF PV MODULE DEGRADATION: 2013

SITE-WISE DATA & ANALYSIS

<b>Site No.:</b>	15	<b>Location:</b>	Sager Island Village	<b>Climatic Zone:</b>	Hot & Humid		
<b>Module No. :</b>	A	<b>Type:</b>	Multi Crystalline Silicon	<b>Power Rating:</b>	40 Wp	<b>Age:</b>	11 years
<b>Degradation Present</b>		<b>Encapsulant</b>	No	<b>Backsheet</b>	Yes	<b>Metallization</b>	Yes
<b>Details</b>			No Discoloration, No Delamination		Slightly dented		Light Corrosion
<b>Junction Box</b>					No	Intact & Good Seal	
<b>Frame</b>							No
<b>Module Soiling:</b>	Lightly Soiled	<b>Shaded Area:</b>	0 %	<b>Maintenance:</b>	Responsive	<b>End Use:</b>	Light, fan

**Electrical Performance:**

Degradation in Pmax (% per year *)	1.43
Degradation in Isc (% per year *)	2.15
Degradation in Voc (% per year *)	-0.22

\* Based on I-V Curve correction using assumed values for various coefficients (alpha = 0.12% per C, beta = -0.2% per C, Rs=0 & k=0) and assuming linear rate of degradation with time.

**Key Observations:**

- No discoloration and delamination in module
- No discoloration in the Metallization
- Slight dent in backsheet

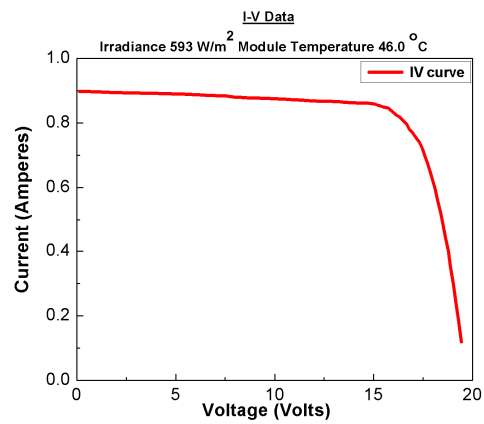

**Recommendations:**

Modules should be cleaned at least once a week since dust on the modules can reduce the power generation.

No Discoloration or delamination



Minor corrosion in the busbars

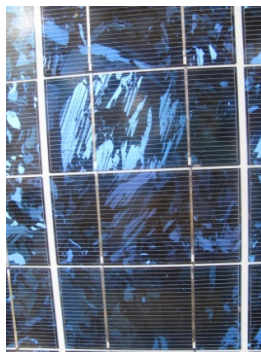

Slight dent in backsheet

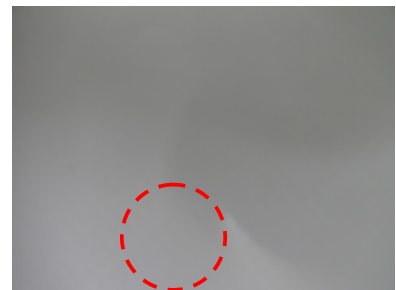

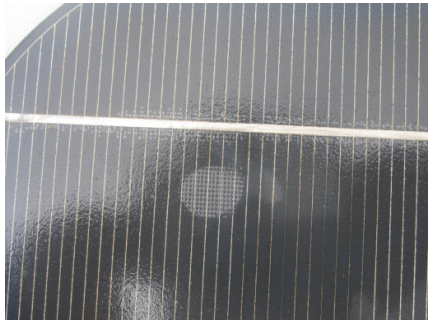
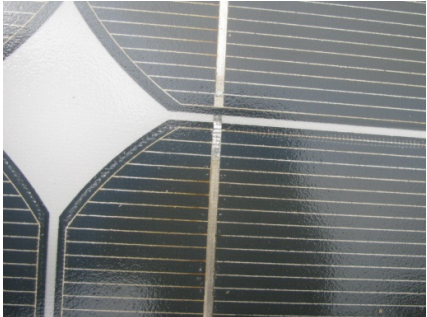

ALL INDIA SURVEY OF PV MODULE DEGRADATION: 2013

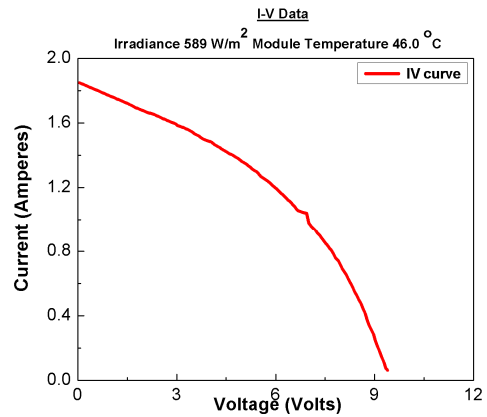

SITE-WISE DATA & ANALYSIS					
<b>Site No.:</b> 16	<b>Location:</b> Sager Island Village	<b>Climatic Zone:</b>	Hot & Humid		
<b>Module No. :</b> A	<b>Type:</b> Mono Crystalline Silicon	<b>Power Rating:</b> 75 Wp	<b>Age:</b>	11 years	
	<b>Encapsulant</b>	<b>Backsheet</b>	<b>Metallization</b>	<b>Junction Box</b>	<b>Frame</b>
<b>Degradation Present</b>	Yes	Yes	Yes	No	No
<b>Details</b>	Dark Discoloration, Delamination from module edges	Extensive, burn marks, delamination	Light Corrosion	Intact & Good Seal	Like new
<b>Module Soiling:</b>	Lightly Soiled	<b>Shaded Area:</b> 0 %	<b>Maintenance:</b>	Responsive	<b>End Use:</b> light, fan
<b>Electrical Performance:</b>					
Degradation in Pmax (% per year *)	Not Calculated (due to low Irradiance)				
Degradation in Isc (% per year *)	Not Calculated (due to low Irradiance)				
Degradation in Voc (% per year *)	Not Calculated (due to low Irradiance)				
* Based on I-V Curve correction using assumed values for various coefficients (alpha = 0.12% per C, beta = -0.2% per C, Rs=0 & k=0) and assuming linear rate of degradation with time.					
<b>Key Observations:</b>					
<ul style="list-style-type: none"> <li>• Yellow discoloration and delamination between glass and encapsulant</li> <li>• Corrosion of the Metallization (fingers)</li> <li>• Extensive burn marks on the backsheet</li> </ul>					
<b>Recommendations:</b>					
Installation should be rectified by leaving sufficient space at the back side to enable faster cooling rate. Modules should be cleaned at least once a week since dust on the modules can reduce the power generation.					
<b>Yellow Discoloration</b>		<b>Delamination between glass and Encapsulant</b>		<b>Corrosion of the fingers</b>	
					

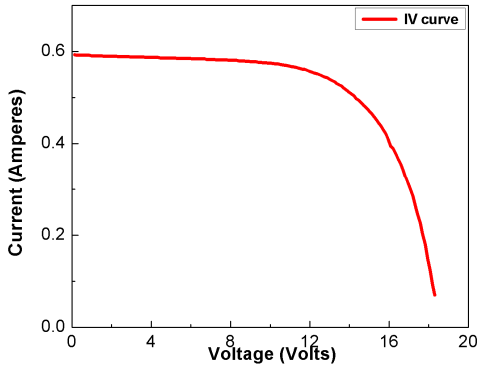

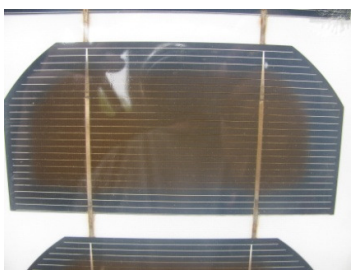
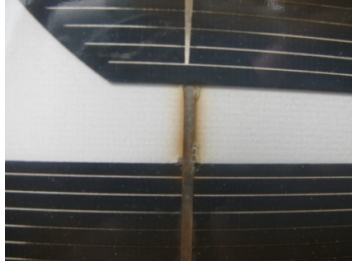
ALL INDIA SURVEY OF PV MODULE DEGRADATION: 2013

SITE-WISE DATA & ANALYSIS						
<b>Site No.:</b>	17	<b>Location:</b>	Sager Island Village	<b>Climatic Zone:</b>	Hot & Humid	
<b>Module No. :</b>	A	<b>Type:</b>	Mono Crystalline Silicon	<b>Power Rating:</b>	40 Wp	<b>Age:</b> 18 years
<b>Degradation Present</b>	<b>Encapsulant</b>	<b>Backsheet</b>	<b>Metallization</b>	<b>Junction Box</b>	<b>Frame</b>	
	Yes	Yes	Yes	No	No	
<b>Details</b>	Dark Discoloration, Delamination	Extensive Burn marks, delamination.	Dark Corrosion	Intact & Good Seal	Like new	
<b>Module Soiling:</b>	Lightly Soiled	<b>Shaded Area:</b>	0 – 25 %	<b>Maintenance:</b>	Responsive	<b>End Use:</b> Light, fan
<b>Electrical Performance:</b>			<b>I-V Data</b>			
Degradation in Pmax (% per year *)	0.33					
Degradation in Isc (% per year *)	1.04					
Degradation in Voc (% per year *)	-1.15					
<p>* Based on I-V Curve correction using assumed values for various coefficients (alpha = 0.12% per C, beta = -0.2% per C, Rs=0 &amp; k=0) and assuming linear rate of degradation with time.</p> <p><b>Key Observations:</b></p> <ul style="list-style-type: none"> <li>• Dark discoloration and delamination in cell</li> <li>• Heavy discoloration in the Metallization and interconnects</li> <li>• Extensive burn marks on the backsheet</li> </ul>						
<b>Recommendations:</b>						
<p>Installation should be rectified by leaving sufficient space at the back side to enable faster cooling rate. Modules should be cleaned at least once a week since dust on the modules can reduce the power generation.</p>						
<b>Degradation visible in all solar cells</b>		<b>Discoloration at the middle of the Solar cell</b>		<b>Corrosion of the cell Interconnects</b>		
						

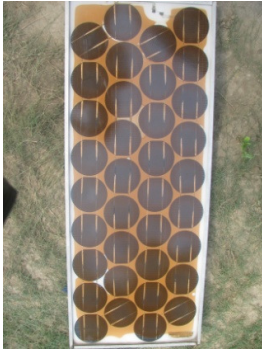
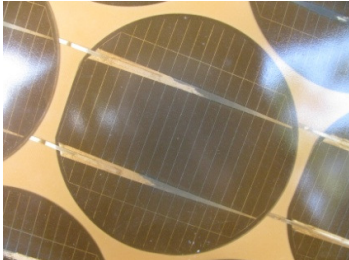
## ALL INDIA SURVEY OF PV MODULE DEGRADATION: 2013

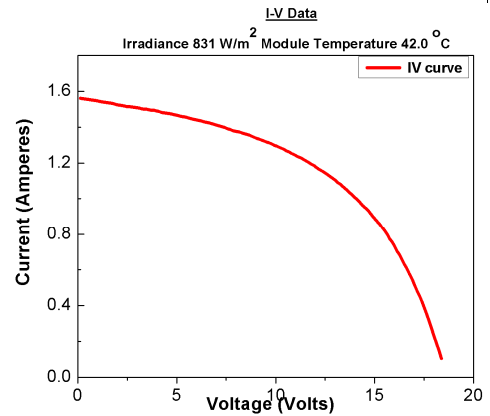

<b>SITE-WISE DATA &amp; ANALYSIS</b>					
<b>Site No.:</b>	18	<b>Location:</b>	Sager Island Village	<b>Climatic Zone:</b>	Hot & Humid
<b>Module No. :</b>	A	<b>Type:</b>	Mono Crystalline Silicon	<b>Power Rating:</b>	40 Wp
				<b>Age:</b>	25 years
	<b>Encapsulant</b>	<b>Backsheet</b>	<b>Metallization</b>	<b>Junction Box</b>	<b>Frame</b>
<b>Degradation Present</b>	Yes	Yes	Yes	No	Yes
<b>Details</b>	Dark Discoloration, Delamination	Extensive, Burn marks, delamination	Dark Corrosion	Intact & Good Seal	Minor damage & corrosion
<b>Module Soiling:</b>	Lightly Soiled	<b>Shaded Area:</b>	~100 %	<b>Maintenance:</b>	Responsive
				<b>End Use:</b>	Light, fan
<b>Electrical Performance:</b>					
Degradation in Pmax (% per year *)	Not Calculated (due to low Irradiance)				
Degradation in Isc (% per year *)	Not Calculated (due to low Irradiance)				
Degradation in Voc (% per year *)	Not Calculated (due to low Irradiance)				
* Based on I-V Curve correction using assumed values for various coefficients (alpha = 0.12% per C, beta = -0.2% per C, Rs=0 & k=0) and assuming linear rate of degradation with time.					
<b>Key Observations:</b>					
<ul style="list-style-type: none"> <li>Dark discoloration and delamination in module</li> <li>Heavy corrosion of the Metallization</li> <li>Extensive burn marks and delamination on the backsheet.</li> <li>Heavy shading from nearby trees, which will degrade the module performance</li> </ul>					
<b>Recommendations:</b>					
Installation should be rectified by leaving sufficient space at the back side to enable faster cooling rate. Modules should be cleaned at least once a week since dust on the modules can reduce the power generation. Nearby trees to be pruned to get higher energy generation and longer module life.					
<b>Dark Discoloration</b>		<b>Corrosion of Metallization</b>		<b>Delamination below the solar cell</b>	
					

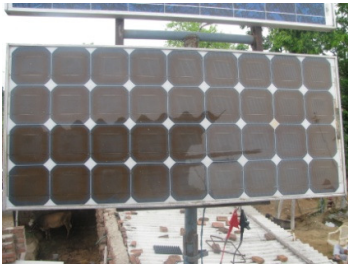
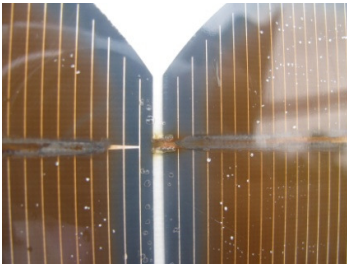
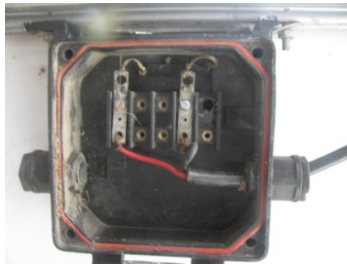

ALL INDIA SURVEY OF PV MODULE DEGRADATION: 2013



SITE-WISE DATA & ANALYSIS					
<b>Site No.:</b> 19	<b>Location:</b> Patna	<b>Climatic Zone:</b> Composite			
<b>Module No. :</b> A	<b>Type:</b> Mono Crystalline Silicon	<b>Power Rating:</b> 75 Wp	<b>Age:</b> 15 years		
	<b>Encapsulant</b>	<b>Backsheet</b>	<b>Metallization</b>	<b>Junction Box</b>	<b>Frame</b>
<b>Degradation Present</b>	Yes	No	Yes	No	Yes
<b>Details</b>	Dark Discoloration, Delamination from edges	Like New	Dark Corrosion	Intact & Good Seal	damaged, frame bent
<b>Module Soiling:</b>	Lightly Soiled	<b>Shaded Area:</b>	~100%	<b>Maintenance:</b>	Preventive
		<b>End Use:</b>	light, fan		
<b>Electrical Performance:</b>					
Degradation in Pmax (% per year *)		Not Calculated (due to low Irradiance)		<b>I-V could not be obtained because of very low irradiance</b>	
Degradation in Isc (% per year *)		Not Calculated (due to low Irradiance)			
Degradation in Voc (% per year *)		Not Calculated (due to low Irradiance)			
* Based on I-V Curve correction using assumed values for various coefficients (alpha = 0.12% per C, beta =-0.2% per C, Rs=0 & k=0) and assuming linear rate of degradation with time.					
<b>Key Observations:</b>					
<ul style="list-style-type: none"> <li>• Dark discoloration and delamination in cells</li> <li>• Heavy corrosion of the Metallization (fingers and interconnects)</li> <li>• Heavy shading from nearby trees, which will degrade the module performance</li> <li>• Bypass diode removed from the junction box</li> </ul>					
<b>Recommendations:</b>					
Nearby trees to be pruned to get higher energy generation and longer module life. If the module has to be used in series bypass diode must present for higher energy generation. Modules should be cleaned at least once a week since dust on the modules can reduce the power generation.					
<b>Discoloration in all solar cells</b>		<b>Corrosion in cell interconnects</b>		<b>Improper connection in junction box</b>	
					

ALL INDIA SURVEY OF PV MODULE DEGRADATION: 2013

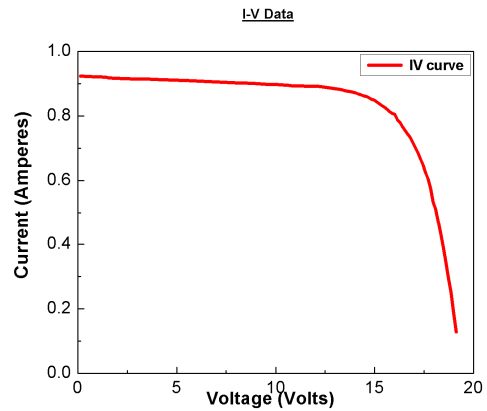
SITE-WISE DATA & ANALYSIS					
<b>Site No.:</b> 19	<b>Location:</b> Patna	<b>Climatic Zone:</b> Composite			
<b>Module No. :</b> B	<b>Type:</b> Multi Crystalline Silicon	<b>Power Rating:</b> 75 Wp	<b>Age:</b> 5 years		
	<b>Encapsulant</b>	<b>Backsheet</b>	<b>Metallization</b>	<b>Junction Box</b>	<b>Frame</b>
<b>Degradation Present</b>	No	No	No	No	No
<b>Details</b>	Like New	Like New	Like New	Intact & Good Seal	Like New
<b>Module Soiling:</b> Lightly Soiled	<b>Shaded Area:</b> ~100%	<b>Maintenance:</b> Preventive	<b>End Use:</b> light, fan		
<b>Electrical Performance:</b>					
Degradation in Pmax (% per year *)	Not Calculated (due to low Irradiance)				
Degradation in Isc (% per year *)	Not Calculated (due to low Irradiance)				
Degradation in Voc (% per year *)	Not Calculated (due to low Irradiance)				
* Based on I-V Curve correction using assumed values for various coefficients (alpha = 0.12% per C, beta =-0.2% per C, Rs=0 & k=0) and assuming linear rate of degradation with time.					
<b>Key Observations:</b>					
<ul style="list-style-type: none"> <li>No discoloration and delamination in cell</li> <li>No discoloration in the metallization</li> <li>Heavy shading from nearby trees, which will degrade the module performance</li> </ul>					
<b>Recommendations:</b>					
Nearby trees to be pruned to get higher energy generation and longer module life. Modules should be cleaned at least once a week since dust on the modules can reduce the power generation.					
<b>Lightly soiled module</b>		<b>No discoloration in metallization</b>		<b>Mild corrosion in the string interconnects</b>	
					



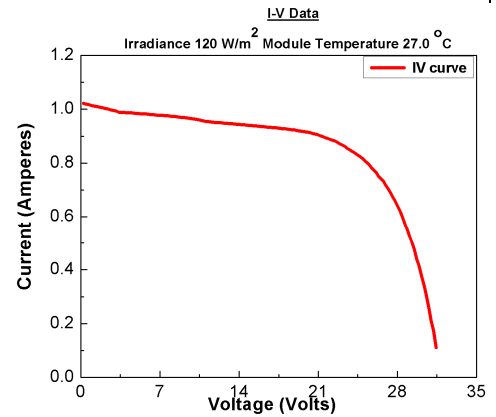

## ALL INDIA SURVEY OF PV MODULE DEGRADATION: 2013

<b>SITE-WISE DATA &amp; ANALYSIS</b>						
<b>Site No.:</b>	20	<b>Location:</b>	Patna	<b>Climatic Zone:</b>	Composite	
<b>Module No. :</b>	A	<b>Type:</b>	Multi Crystalline Silicon	<b>Power Rating:</b>	232 Wp	<b>Age:</b> 2 years
	<b>Encapsulant</b>	<b>Backsheet</b>	<b>Metallization</b>	<b>Junction Box</b>	<b>Frame</b>	
<b>Degradation Present</b>	No	No	Yes	No	No	
<b>Details</b>	Like New	Like New	Light corrosion	Intact & Good Seal	Like New	
<b>Module Soiling:</b>	Lightly Soiled	<b>Shaded Area:</b>	0 %	<b>Maintenance:</b>	Preventive	<b>End Use:</b> DC Water Pump
<b>Electrical Performance:</b>						
Degradation in Pmax (% per year *)	Not Calculated (due to low Irradiance)					
Degradation in Isc (% per year *)	Not Calculated (due to low Irradiance)					
Degradation in Voc (% per year *)	Not Calculated (due to low Irradiance)					
* Based on I-V Curve correction using assumed values for various coefficients (alpha = 0.12% per C, beta = -0.2% per C, Rs=0 & k=0) and assuming linear rate of degradation with time.						
<b>Key Observations:</b>						
<ul style="list-style-type: none"> <li>No discoloration and delamination in cell</li> <li>Light corrosion in the metallization (bus bars)</li> <li>Front glass broken and dented</li> </ul>						
<b>Recommendations:</b>						
It is safety hazard to use a module with broken glass. Modules should be cleaned at least once a week since dust on the modules can reduce the power generation.						
<b>Module with Shattered Glass</b>		<b>Dent in the front glass</b>		<b>Corrosion in the busbar</b>		
						



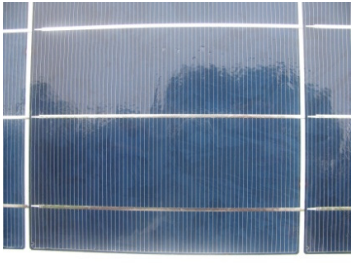

## ALL INDIA SURVEY OF PV MODULE DEGRADATION: 2013

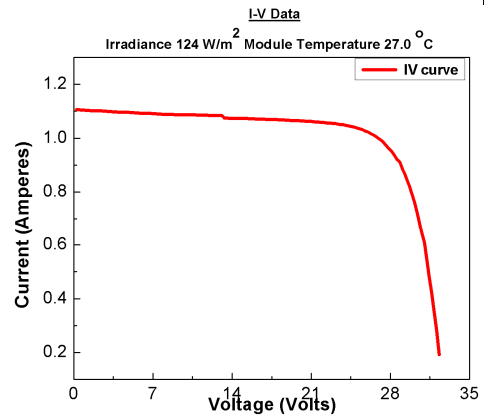
SITE-WISE DATA & ANALYSIS						
<b>Site No.:</b> 20	<b>Location:</b> Patna	<b>Climatic Zone:</b> Composite				
<b>Module No. :</b> B	<b>Type:</b> Multi Crystalline Silicon	<b>Power Rating:</b> 232 Wp	<b>Age:</b> 2 years			
	<b>Encapsulant</b>	<b>Backsheet</b>	<b>Metallization</b>	<b>Junction Box</b>	<b>Frame</b>	
<b>Degradation Present</b>	No	No	No	No	No	
<b>Details</b>	Like New	Like New	Like New	Intact & Good Seal	Like New	
<b>Module Soiling:</b>	Lightly Soiled	<b>Shaded Area:</b> 0 %	<b>Maintenance:</b> Preventive	<b>End Use:</b> DC Water Pump		
<b>Electrical Performance:</b>						
Degradation in Pmax (% per year *)	Not Calculated (due to low Irradiance)					
Degradation in Isc (% per year *)	Not Calculated (due to low Irradiance)					
Degradation in Voc (% per year *)	Not Calculated (due to low Irradiance)					
* Based on I-V Curve correction using assumed values for various coefficients (alpha = 0.12% per C, beta = -0.2% per C, Rs=0 & k=0) and assuming linear rate of degradation with time.						
<b>Key Observations:</b>						
<ul style="list-style-type: none"> <li>• No discoloration and delamination in cell</li> <li>• No discoloration in the metallization</li> <li>• Junction box intact</li> </ul>						
<b>Recommendations:</b>						
Modules should be cleaned at least once a week since dust on the modules can reduce the power generation.						
<b>Lightly soiled module</b>		<b>Solar Cell</b>		<b>Junction Box</b>		
						



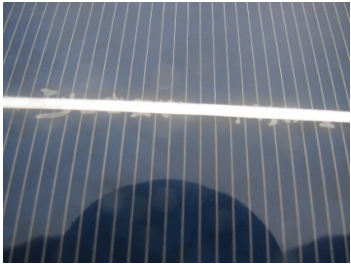

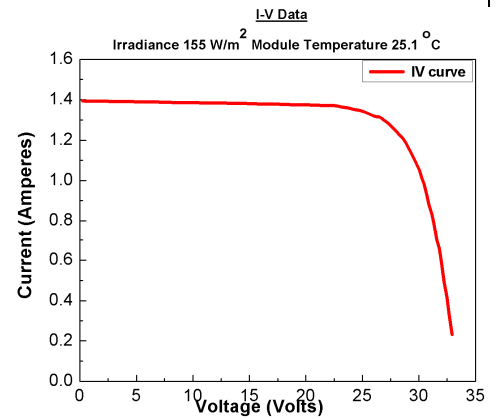

## ALL INDIA SURVEY OF PV MODULE DEGRADATION: 2013

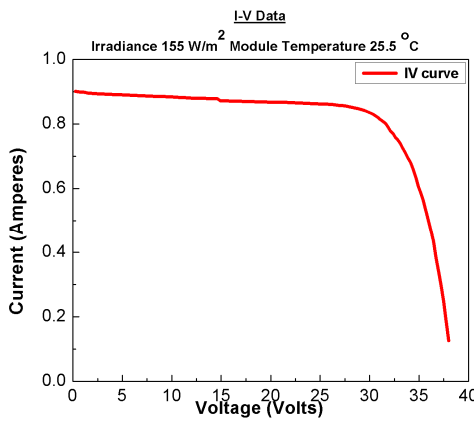

SITE-WISE DATA & ANALYSIS					
<b>Site No.:</b> 21	<b>Location:</b> Patna	<b>Climatic Zone:</b> Composite			
<b>Module No. :</b> A	<b>Type:</b> Multi Crystalline Silicon	<b>Power Rating:</b> 235 Wp	<b>Age:</b> 3 years		
	<b>Encapsulant</b>	<b>Backsheet</b>	<b>Metallization</b>	<b>Junction Box</b>	<b>Frame</b>
<b>Degradation Present</b>	No	No	No	No	No
<b>Details</b>	Like New	Like New	Like New	Intact & Good Seal	Like New
<b>Module Soiling:</b> Cleaned	<b>Shaded Area:</b> 0 %	<b>Maintenance:</b> Preventive	<b>End Use:</b> DC Water Pump		
<b>Electrical Performance:</b>					
Degradation in Pmax (% per year *)	Not Calculated (due to low Irradiance)				
Degradation in Isc (% per year *)	Not Calculated (due to low Irradiance)				
Degradation in Voc (% per year *)	Not Calculated (due to low Irradiance)				
* Based on I-V Curve correction using assumed values for various coefficients (alpha = 0.12% per C, beta = -0.2% per C, Rs=0 & k=0) and assuming linear rate of degradation with time.					
<b>Key Observations:</b>					
<ul style="list-style-type: none"> <li>No discoloration and delamination in cell</li> <li>No discoloration in the metallization</li> <li>Junction box intact</li> </ul>					
<b>Recommendations:</b>					
Modules should be cleaned at least once a week since dust on the modules can reduce the power generation.					
<b>Lightly soiled module</b>		<b>Solar cell</b>		<b>Junction box</b>	
					



## ALL INDIA SURVEY OF PV MODULE DEGRADATION: 2013

SITE-WISE DATA & ANALYSIS					
<b>Site No.:</b> 21	<b>Location:</b> Patna	<b>Climatic Zone:</b> Composite			
<b>Module No. :</b> B	<b>Type:</b> Multi Crystalline Silicon	<b>Power Rating:</b> 235 Wp	<b>Age:</b> 3 years		
	<b>Encapsulant</b>	<b>Backsheet</b>	<b>Metallization</b>	<b>Junction Box</b>	<b>Frame</b>
<b>Degradation Present</b>	No	No	No	No	No
<b>Details</b>	-	-	-	-	-
<b>Module Soiling:</b> Cleaned	<b>Shaded Area:</b> 0 %	<b>Maintenance:</b> Preventive	<b>End Use:</b> DC Water Pump		
<b>Electrical Performance:</b>					
Degradation in Pmax (% per year *)		Not Calculated (due to low Irradiance)			
Degradation in Isc (% per year *)		Not Calculated (due to low Irradiance)			
Degradation in Voc (% per year *)		Not Calculated (due to low Irradiance)			
* Based on I-V Curve correction using assumed values for various coefficients (alpha = 0.12% per C, beta =-0.2% per C, Rs=0 & k=0) and assuming linear rate of degradation with time.					
<b>Key Observations:</b>					
<ul style="list-style-type: none"> <li>• No discoloration or delamination on the solar cells</li> <li>• Light discoloration in an area between cell and frame</li> </ul>					
					
<b>Recommendations:</b>					
Modules should be cleaned at least once a week since dust on the modules can reduce the power generation.					
<b>No discoloration on solar cells</b>		<b>Light discoloration between cell and frame</b>		<b>Junction box intact</b>	
					

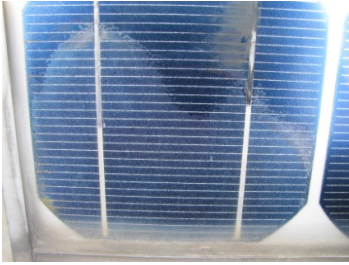
ALL INDIA SURVEY OF PV MODULE DEGRADATION: 2013

SITE-WISE DATA & ANALYSIS						
<b>Site No.:</b> 22	<b>Location:</b> Gurgaon	<b>Climatic Zone:</b> Composite				
<b>Module No. :</b> A	<b>Type:</b> Mono Crystalline Silicon	<b>Power Rating:</b> 75 Wp	<b>Age:</b> 14 years			
	<b>Encapsulant</b>	<b>Backsheet</b>	<b>Metallization</b>	<b>Junction Box</b>	<b>Frame</b>	
<b>Degradation Present</b>	Yes	No	Yes	No	Yes	
<b>Details</b>	Dark Discoloration, Delamination over cells	Like New	Light Corrosion	Intact & Good Seal	Minor damage & corrosion	
<b>Module Soiling:</b> Lightly Soiled	<b>Shaded Area:</b> 0 %	<b>Maintenance:</b> Preventive	<b>End Use:</b> Research purpose			
<b>Electrical Performance:</b>						
Degradation in Pmax (% per year *)	1.01					
Degradation in Isc (% per year *)	0.52					
Degradation in Voc (% per year *)	0.10					
* Based on I-V Curve correction using assumed values for various coefficients (alpha = 0.12% per C, beta = -0.2% per C, Rs=0 & k=0) and assuming linear rate of degradation with time.						
<b>Key Observations:</b>						
<ul style="list-style-type: none"> <li>• Discoloration at the centre of a few solar cells</li> <li>• Major delamination and corrosion in 1 solar cell</li> <li>• Hard-to-remove dust deposits on the lower edge of the module</li> <li>• Chalking (white powder) from the backsheet</li> <li>• Tilt angle of Module is 35 deg. whereas Latitude is 28.5 deg.</li> <li>• (Non-optimum tilt)</li> </ul>						
<b>Recommendations:</b>						
Since the modules have been installed for research purpose and not for power generation, the research project's requirements need to be followed.						
<b>Module having significant variation in the colour of the solar cells</b>		<b>Major delamination and corrosion</b>		<b>Chalking (white powder) from backsheet</b>		
						

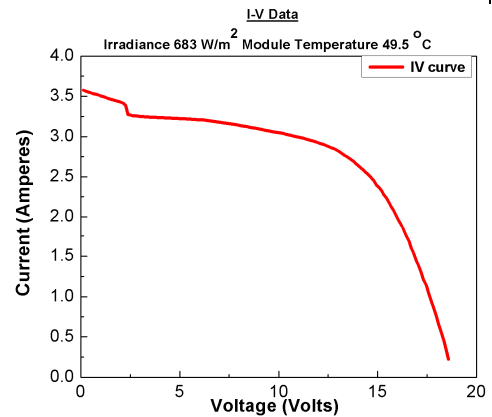

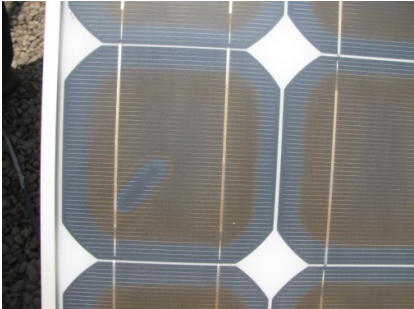
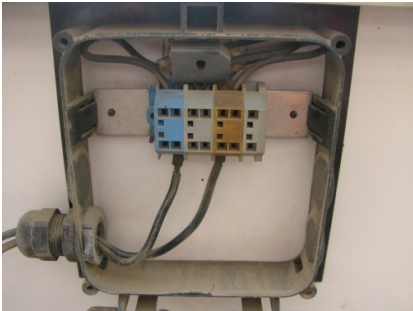

## ALL INDIA SURVEY OF PV MODULE DEGRADATION: 2013

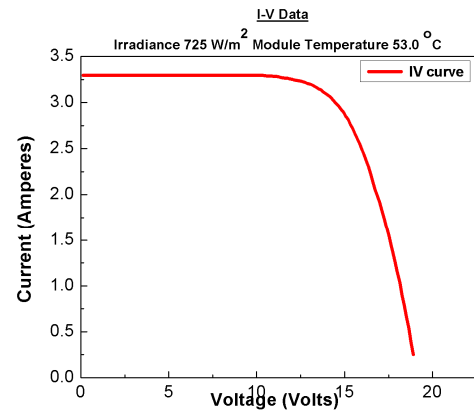
<b>SITE-WISE DATA &amp; ANALYSIS</b>					
<b>Site No.:</b> 22	<b>Location:</b> Gurgaon	<b>Climatic Zone:</b> Composite			
<b>Module No. :</b> B	<b>Type:</b> Mono Crystalline Silicon	<b>Power Rating:</b> 75 Wp	<b>Age:</b> 14 years		
	<b>Encapsulant</b>	<b>Backsheet</b>	<b>Metallization</b>	<b>Junction Box</b>	<b>Frame</b>
<b>Degradation Present</b>	Yes	No	Yes	No	No
<b>Details</b>	Dark Discoloration, No Delamination	Like New	Dark Corrosion	Intact & Good Seal	Like New
<b>Module Soiling:</b>	Lightly Soiled	<b>Shaded Area:</b>	0 %	<b>Maintenance:</b>	Preventive
		<b>End Use:</b>			Research purpose
<b>Electrical Performance:</b>					
Degradation in Pmax (% per year *)	0.86				
Degradation in Isc (% per year *)	0.84				
Degradation in Voc (% per year *)	0.16				
* Based on I-V Curve correction using assumed values for various coefficients (alpha = 0.12% per C, beta =-0.2% per C, Rs=0 & k=0) and assuming linear rate of degradation with time.					
<b>Key Observations:</b>					
<ul style="list-style-type: none"> <li>All cells have dark discolorations, but no delamination</li> <li>Corrosion in small portions of some busbars</li> <li>Small cracks in some solar cells have caused photo-oxidative bleaching of the discoloured encapsulant</li> <li>The connection cables have degraded significantly</li> <li>Tilt angle of Module is 37 deg. whereas Latitude is 28.5 deg.</li> <li>(Non-optimum tilt)</li> </ul>					
<b>Recommendations:</b>					
Since the modules have been installed for research purpose and not for power generation, the research project's requirements need to be followed.					
<b>Yellow Discoloration</b>		<b>Uneven discoloration caused by crack in the cell</b>		<b>Connecting wires are degraded</b>	
					



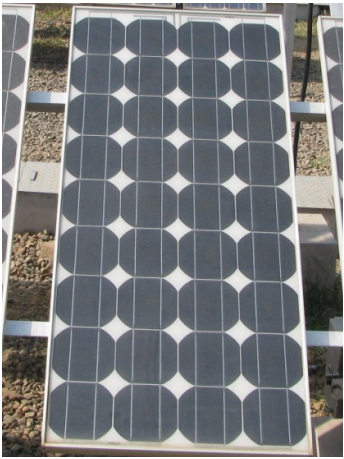
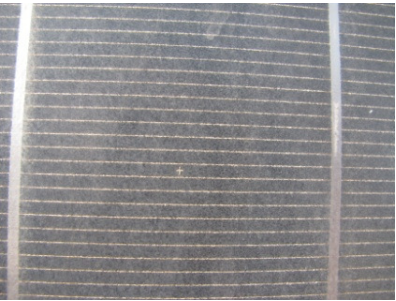

ALL INDIA SURVEY OF PV MODULE DEGRADATION: 2013

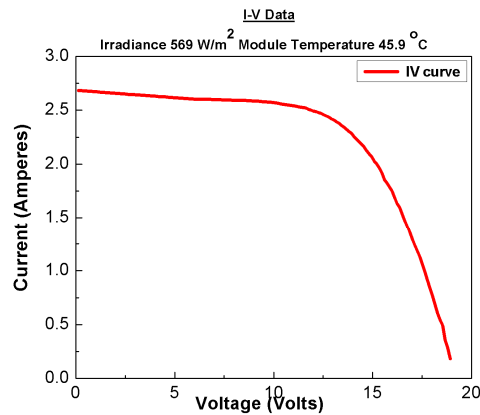
SITE-WISE DATA & ANALYSIS					
<b>Site No.:</b> 22	<b>Location:</b> Gurgaon	<b>Climatic Zone:</b> Composite			
<b>Module No. :</b> C	<b>Type:</b> Mono Crystalline Silicon	<b>Power Rating:</b> 70 Wp	<b>Age:</b> 14 years		
	<b>Encapsulant</b>	<b>Backsheet</b>	<b>Metallization</b>	<b>Junction Box</b>	<b>Frame</b>
<b>Degradation Present</b>	Yes	No	No	No	No
<b>Details</b>	Light Discoloration, No Delamination	Like New	Like New	Intact & Good Seal	Like New
<b>Module Soiling:</b>	Lightly Soiled	<b>Shaded Area:</b> 0 %	<b>Maintenance:</b> Preventive	<b>End Use:</b> Research purpose	
<b>Electrical Performance:</b>					
Degradation in Pmax (% per year *)	0.55				
Degradation in Isc (% per year *)	0.06				
Degradation in Voc (% per year *)	-0.17				
* Based on I-V Curve correction using assumed values for various coefficients (alpha = 0.12% per C, beta =-0.2% per C, Rs=0 & k=0) and assuming linear rate of degradation with time.					
<b>Key Observations:</b>					
<ul style="list-style-type: none"> <li>• Light discoloration but no delamination</li> <li>• Corrosion in the cell interconnect</li> <li>• Cover glass has become hazy</li> <li>• The cables have become weathered and degraded</li> <li>• Tilt angle of Module is 37 deg. whereas Latitude is 28.5 deg.</li> <li>• (Non-optimum tilt)</li> </ul>					
<b>Recommendations:</b>					
Since the modules have been installed for research purpose and not for power generation, the research project's requirements need to be followed.					
<b>Light Discoloration</b>		<b>Corrosion in busbar and Haziness in glass</b>		<b>Minor corrosion in output terminals, but wires degraded</b>	
					



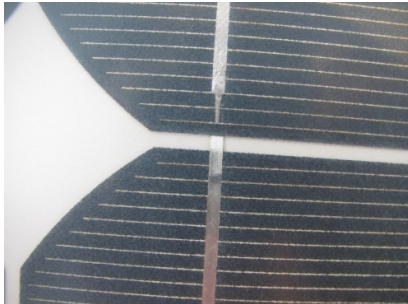

## ALL INDIA SURVEY OF PV MODULE DEGRADATION: 2013

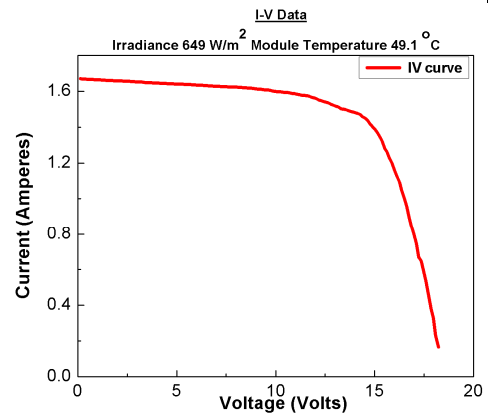
SITE-WISE DATA & ANALYSIS					
<b>Site No.:</b> 22	<b>Location:</b> Gurgaon	<b>Climatic Zone:</b> Composite			
<b>Module No. :</b> D	<b>Type:</b> Mono Crystalline Silicon	<b>Power Rating:</b> 75 Wp	<b>Age:</b> 14 years		
	<b>Encapsulant</b>	<b>Backsheet</b>	<b>Metallization</b>	<b>Junction Box</b>	<b>Frame</b>
<b>Degradation Present</b>	Yes	No	Yes	No	Yes
<b>Details</b>	Light Discoloration, No Delamination	Like New	Light Corrosion	Intact & Good Seal	Minor damage & corrosion
<b>Module Soiling:</b>	Lightly Soiled	<b>Shaded Area:</b>	0 %	<b>Maintenance:</b>	Preventive
		<b>End Use:</b>			Research purpose
<b>Electrical Performance:</b>					
Degradation in Pmax (% per year *)	0.56				
Degradation in Isc (% per year *)	0.79				
Degradation in Voc (% per year *)	-0.95				
* Based on I-V Curve correction using assumed values for various coefficients (alpha = 0.12% per C, beta = -0.2% per C, Rs=0 & k=0) and assuming linear rate of degradation with time.					
<b>Key Observations:</b>					
<ul style="list-style-type: none"> <li>• Light discoloration but no delamination</li> <li>• Corrosion of the cell interconnects</li> <li>• Corrosion of the output terminals</li> <li>• Tilt angle of Module is 37 deg. whereas Latitude is 28.5deg.</li> <li>• (Non-optimum tilt)</li> </ul>					
<b>Recommendations:</b>					
Since the modules have been installed for research purpose and not for power generation, the research project's requirements need to be followed.					
<b>Light discoloration in the module</b>		<b>Corrosion of cell interconnects</b>		<b>Corrosion in Output terminals</b>	
					



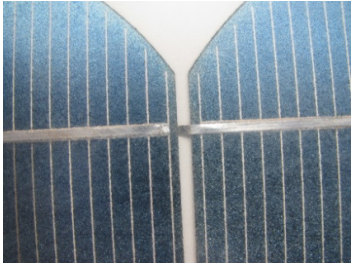

## ALL INDIA SURVEY OF PV MODULE DEGRADATION: 2013

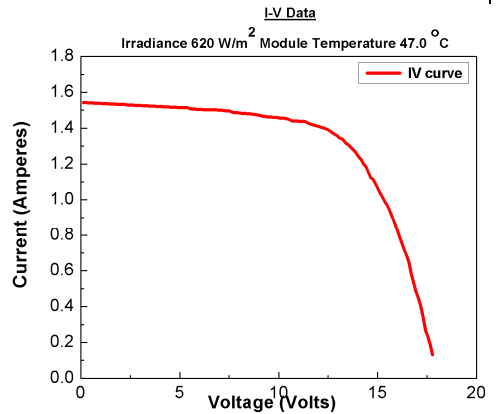
SITE-WISE DATA & ANALYSIS					
<b>Site No.:</b> 22	<b>Location:</b> Gurgaon	<b>Climatic Zone:</b> Composite			
<b>Module No. :</b> E	<b>Type:</b> Mono Crystalline Silicon	<b>Power Rating:</b> 75 Wp	<b>Age:</b> 14 years		
	<b>Encapsulant</b>	<b>Backsheet</b>	<b>Metallization</b>	<b>Junction Box</b>	<b>Frame</b>
<b>Degradation Present</b>	Yes	Yes	Yes	No	Yes
<b>Details</b>	Light Discoloration, No Delamination	Bubbles	Light Corrosion	Intact & Good Seal	Minor damage & corrosion
<b>Module Soiling:</b>	Lightly Soiled	<b>Shaded Area:</b>	0 %	<b>Maintenance:</b>	Preventive
		<b>End Use:</b>	Research purpose		
<b>Electrical Performance:</b>					
Degradation in Pmax (% per year *)	0.03				
Degradation in Isc (% per year *)	0.01				
Degradation in Voc (% per year *)	-1.07				
* Based on I-V Curve correction using assumed values for various coefficients (alpha = 0.12% per C, beta = -0.2% per C, Rs=0 & k=0) and assuming linear rate of degradation with time.					
<b>Key Observations:</b>					
<ul style="list-style-type: none"> <li>Light discoloration on some of the solar cells but no delamination</li> <li>Mild corrosion of the metallization in a few cells</li> <li>Output terminals are corroded and soiled</li> <li>Tilt angle of Module is 35 deg. whereas Latitude is 28.5 deg.</li> <li>(Non-optimum tilt)</li> </ul>					
<b>Recommendations:</b>					
Since the modules have been installed for research purpose and not for power generation, the research project's requirements need to be followed.					
<b>Light discoloration on some solar cells</b>		<b>Mild corrosion of the metallization</b>		<b>Corrosion of output terminals</b>	
					



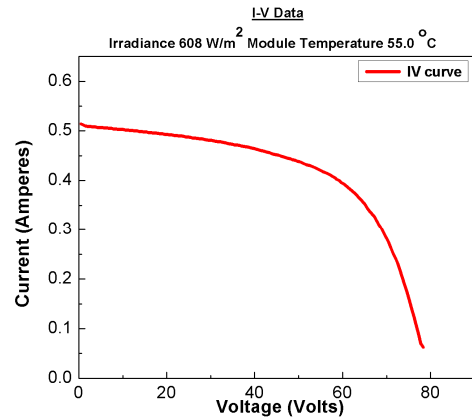

## ALL INDIA SURVEY OF PV MODULE DEGRADATION: 2013

<b>SITE-WISE DATA &amp; ANALYSIS</b>					
<b>Site No.:</b> 22	<b>Location:</b> Gurgaon	<b>Climatic Zone:</b> Composite			
<b>Module No. :</b> F	<b>Type:</b> a-Si (double tandem)	<b>Power Rating:</b> 43 Wp	<b>Age:</b> 13 years		
	<b>Encapsulant</b>	<b>Backsheet</b>	<b>Metallization</b>	<b>Junction Box</b>	<b>Frame</b>
<b>Degradation Present</b>	Yes	NA	NA	NA	No
<b>Details</b>	Dark Discoloration, Delamination on bottom half	NA	NA	NA	Like new
<b>Module Soiling:</b> Lightly Soiled	<b>Shaded Area:</b> 0 %	<b>Maintenance:</b> Preventive	<b>End Use:</b> Research purpose		
<b>Electrical Performance:</b>					
Degradation in Pmax (% per year *)	0.19				
Degradation in Isc (% per year *)	0.57				
Degradation in Voc (% per year *)	-0.06				
* Based on I-V Curve correction using assumed values for various coefficients (alpha = 0.12% per C, beta = -0.2% per C, Rs=0 & k=0) and assuming linear rate of degradation with time.					
<b>Key Observations:</b>					
<ul style="list-style-type: none"> <li>Major bar graph corrosion is found at the lower part of the module</li> <li>Bar graph corrosion is also found in the top edge of the module, near the electrodes.</li> <li>The module is broken at the two bottom corners.</li> </ul>					
<b>Recommendations:</b>					
Since the modules have been installed for research purpose and not for power generation, the research project's requirements need to be followed.					
<b>Module having major corrosion in the bottom part</b>		<b>Bar Graph Corrosion</b>		<b>Breakage in Module</b>	
					



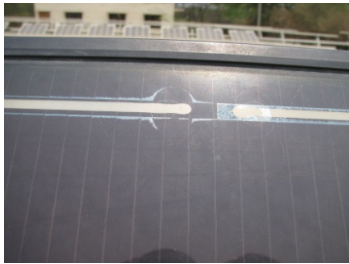

## ALL INDIA SURVEY OF PV MODULE DEGRADATION: 2013

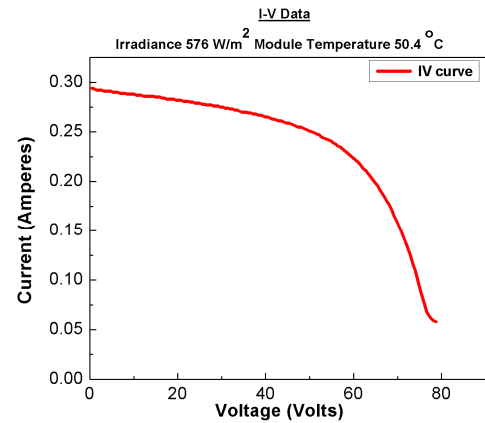
<b>SITE-WISE DATA &amp; ANALYSIS</b>					
<b>Site No.:</b>	22	<b>Location:</b>	Gurgaon	<b>Climatic Zone:</b>	Composite
<b>Module No. :</b>	G	<b>Type:</b>	a-Si(double tandem)	<b>Power Rating:</b>	43 Wp <b>Age:</b> 13 years
	<b>Encapsulant</b>	<b>Backsheet</b>	<b>Metallization</b>	<b>Junction Box</b>	<b>Frame</b>
<b>Degradation Present</b>	Yes	NA	NA	NA	No
<b>Details</b>	Dark Discoloration, Delamination on bottom half	NA	NA	NA	Like new
<b>Module Soiling:</b>	Lightly Soiled	<b>Shaded Area:</b>	0 %	<b>Maintenance:</b>	Preventive <b>End Use:</b> Research purpose
<b>Electrical Performance:</b>					
Degradation in Pmax (% per year *)	3.62				
Degradation in Isc (% per year *)	3.87				
Degradation in Voc (% per year *)	-5.06				
* Based on I-V Curve correction using assumed values for various coefficients (alpha = 0.12% per C, beta = -0.2% per C, Rs=0 & k=0) and assuming linear rate of degradation with time.					
<b>Key Observations:</b>					
<ul style="list-style-type: none"> <li>Small scratch has been found on the glass cover of the module</li> <li>Bar Graph corrosion has started at the top edge of the module, near the electrodes.</li> <li>Tilt angle of Module is 45 deg. whereas Latitude is 28.5 deg.</li> <li>(Non-optimum tilt)</li> </ul>					
<b>Recommendations:</b>					
Since the modules have been installed for research purpose and not for power generation, the research project's requirements need to be followed.					
<b>Amorphous Silicon module</b>		<b>Small scratch in the Glass</b>		<b>Bar graph corrosion near the electrodes</b>	
					



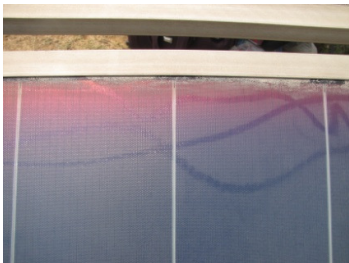

## ALL INDIA SURVEY OF PV MODULE DEGRADATION: 2013

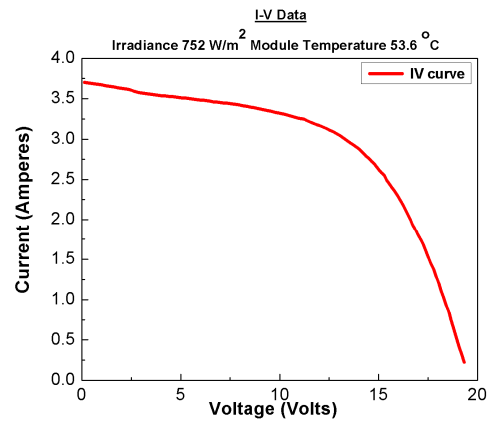
<b>SITE-WISE DATA &amp; ANALYSIS</b>						
<b>Site No.:</b> 22	<b>Location:</b> Gurgaon	<b>Climatic Zone:</b> Composite				
<b>Module No. :</b> H	<b>Type:</b> a-Si(triple tandem)	<b>Power Rating:</b> 64 Wp	<b>Age:</b> 13 years			
	<b>Encapsulant</b>	<b>Backsheet</b>	<b>Metallization</b>	<b>Junction Box</b>	<b>Frame</b>	
<b>Degradation Present</b>	Yes	No	NA	No	No	
<b>Details</b>	Dark Discoloration, Delamination on module center half	Like New	NA	Intact & Good Seal	Like New	
<b>Module Soiling:</b>	Lightly Soiled	<b>Shaded Area:</b>	0 %	<b>Maintenance:</b>	Preventive	<b>End Use:</b> Research purpose
<b>Electrical Performance:</b>						
Degradation in Pmax (% per year *)	0.53					
Degradation in Isc (% per year *)	0.16					
Degradation in Voc (% per year *)	0.68					
* Based on I-V Curve correction using assumed values for various coefficients (alpha = 0.12% per C, beta = -0.2% per C, Rs=0 & k=0) and assuming linear rate of degradation with time.						
<b>Key Observations:</b>						
<ul style="list-style-type: none"> <li>• “Snail tracks” are visible on the surface of the module, both through naked eye, and also in Infra-red images.</li> <li>• The output terminals are corroded, and soiled.</li> <li>• Tilt angle of Module is 45 deg. whereas Latitude is 28.5 deg.</li> <li>• (Non-optimum tilt)</li> </ul>						
<b>Recommendations:</b>						
Since the modules have been installed for research purpose and not for power generation, the research project’s requirements need to be followed.						
<b>Amorphous silicon module</b>		<b>“snail-trail”-like feature</b>		<b>Corrosion in output terminals</b>		
						



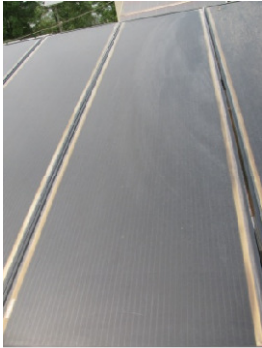

ALL INDIA SURVEY OF PV MODULE DEGRADATION: 2013

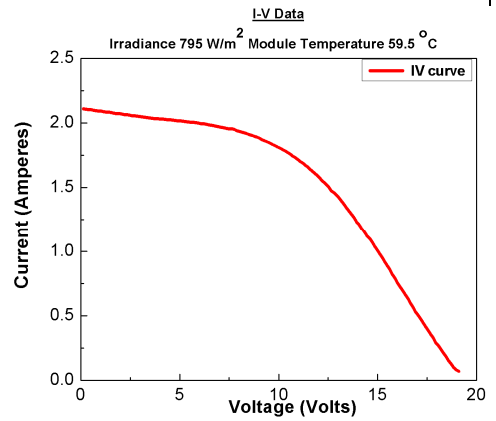
SITE-WISE DATA & ANALYSIS					
<b>Site No.:</b> 22	<b>Location:</b> Gurgaon	<b>Climatic Zone:</b> Composite			
<b>Module No. :</b> I	<b>Type:</b> CIGS	<b>Power Rating:</b> 40 Wp		<b>Age:</b> 13 years	
	<b>Encapsulant</b>	<b>Backsheet</b>	<b>Metallization</b>	<b>Junction Box</b>	<b>Frame</b>
<b>Degradation Present</b>	No	No	NA	Yes	Yes
<b>Details</b>	No Discoloration, No Delamination	Like New	NA	unsound structure	Minor damage & corrosion
<b>Module Soiling:</b> Lightly Soiled	<b>Shaded Area:</b> 0 %	<b>Maintenance:</b> Preventive	<b>End Use:</b> Research purpose		
<b>Electrical Performance:</b>					
Degradation in Pmax (% per year *)	3.96				
Degradation in Isc (% per year *)	0.50				
Degradation in Voc (% per year *)	-0.51				
* Based on I-V Curve correction using assumed values for various coefficients (alpha = 0.12% per C, beta =-0.2% per C, Rs=0 & k=0) and assuming linear rate of degradation with time.					
<b>Key Observations:</b>					
<ul style="list-style-type: none"> <li>• Dark patches were observed near the electrodes.</li> <li>• White powdery deposits were present at the edges of the module.</li> <li>• Puncture in the backsheet of the module.</li> <li>• Tilt angle of Module is 45 deg. whereas Latitude is 28.5 deg.</li> <li>• (Non-optimum tilt)</li> </ul>					
<b>Recommendations:</b>					
Since the modules have been installed for research purpose and not for power generation, the research project's requirements need to be followed.					
<b>CIGS Module</b>		<b>Hard-to-remove deposits on module surface and blackening of electrodes</b>		<b>Corrosion in output terminals</b>	
					

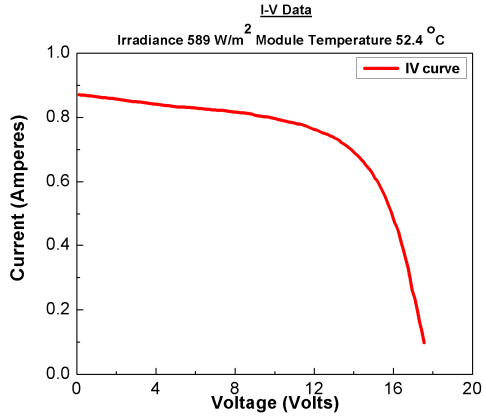
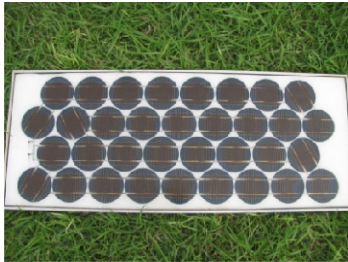
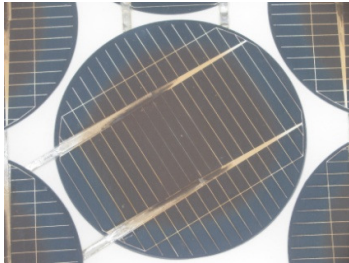

## ALL INDIA SURVEY OF PV MODULE DEGRADATION: 2013

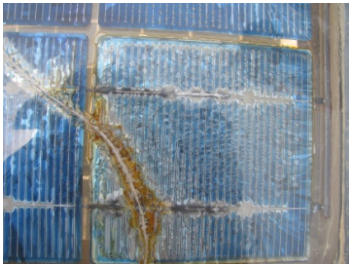
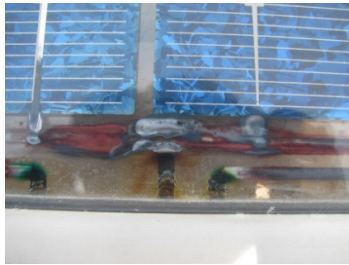

<b>SITE-WISE DATA &amp; ANALYSIS</b>					
<b>Site No.:</b> 23	<b>Location:</b> Gurgaon	<b>Climatic Zone:</b> Composite			
<b>Module No. :</b> A	<b>Type:</b> Mono Crystalline Silicon	<b>Power Rating:</b> 30 Wp	<b>Age:</b> 25 years		
	<b>Encapsulant</b>	<b>Backsheet</b>	<b>Metallization</b>	<b>Junction Box</b>	<b>Frame</b>
<b>Degradation Present</b>	Yes	Yes	Yes	Yes	Yes
<b>Details</b>	Dark Discoloration, No Delamination	Extensive, discolored	Dark Corrosion	loose/brittle	Minor damage & corrosion
<b>Module Soiling:</b>	Heavily Soiled	<b>Shaded Area:</b>	0 – 25 %	<b>Maintenance:</b>	NA
<b>Electrical Performance:</b>					
Degradation in Pmax (% per year *)	0.51				
Degradation in Isc (% per year *)	0.45				
Degradation in Voc (% per year *)	-0.23				
* Based on I-V Curve correction using assumed values for various coefficients (alpha = 0.12% per C, beta = -0.2% per C, Rs=0 & k=0) and assuming linear rate of degradation with time.					
<b>Key Observations:</b>					
<ul style="list-style-type: none"> <li>• Dark discoloration in all the solar cells but no delamination</li> <li>• Corrosion in some portion of the Metallization</li> <li>• Corrosion in output terminals</li> </ul>					
<div style="display: flex; align-items: center;"> <div style="flex: 1;"> <p><b>Recommendations:</b></p> <p>Modules should be cleaned at least once a week since dust on the modules can reduce the power generation. The module junction box should be properly covered so as to prevent entry of water into the junction box.</p> </div> <div style="flex: 1;">  </div> </div>					
<b>Dark Discoloration in middle of all solar cells</b>		<b>Corrosion in cell interconnects</b>		<b>Corrosion in output terminals</b>	
					

## ALL INDIA SURVEY OF PV MODULE DEGRADATION: 2013

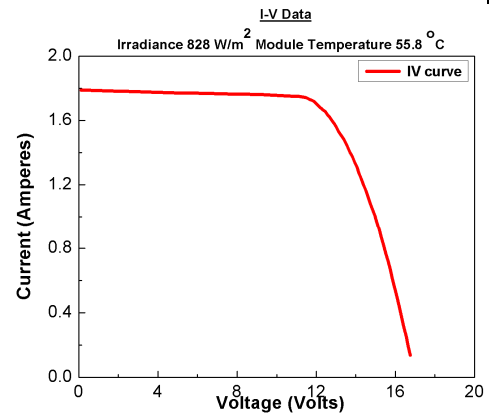
<b>SITE-WISE DATA &amp; ANALYSIS</b>					
<b>Site No.:</b>	24	<b>Location:</b>	Tilonia	<b>Climatic Zone:</b>	Hot & Dry
<b>Module No. :</b>	A	<b>Type:</b>	Multi Crystalline Silicon	<b>Power Rating:</b>	45 Wp <b>Age:</b> 25 years
	<b>Encapsulant</b>	<b>Backsheet</b>	<b>Metallization</b>	<b>Junction Box</b>	<b>Frame</b>
<b>Degradation Present</b>	Yes	NA	Yes	Yes	No
<b>Details</b>	Light Discoloration, Delamination between cells	NA	Dark Corrosion	loose/brittle	Like new
<b>Module Soiling:</b>	Heavily soiled	<b>Shaded Area:</b>	25 – 75%	<b>Maintenance:</b>	Preventive <b>End Use:</b> light, fan
<b>Electrical Performance:</b>					
Degradation in Pmax (% per year *)	1.67				
Degradation in Isc (% per year *)	0.78				
Degradation in Voc (% per year *)	0.52				
* Based on I-V Curve correction using assumed values for various coefficients (alpha = 0.12% per C, beta = -0.2% per C, Rs=0 & k=0) and assuming linear rate of degradation with time.					
<b>Key Observations:</b>					
<ul style="list-style-type: none"> <li>Light discoloration and delamination in cell</li> <li>Discoloration in the Metallization (fingers)</li> <li>Tilt angle of Module is 16 deg. whereas Latitude is 26 deg.</li> <li>(Non-optimum tilt)</li> <li>Heavily soiled</li> <li>Front glass broken</li> </ul>					
<b>Recommendations:</b>					
Tilt Angle should be rectified to get higher energy generation. Modules should be cleaned at least once a week since dust on the modules can reduce the power generation.					
<b>Module having a crack in the glass</b>		<b>Delamination in one of the solar cells through which the crack passes</b>		<b>Major corrosion in the string interconnects</b>	
					



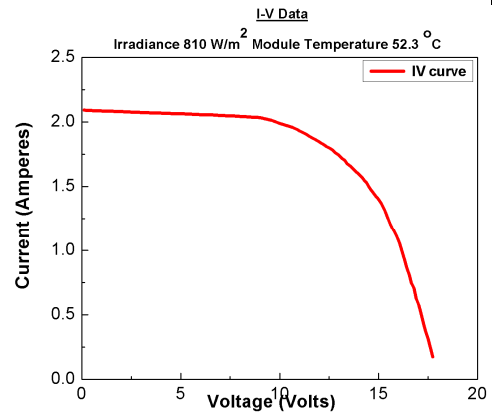

## ALL INDIA SURVEY OF PV MODULE DEGRADATION: 2013

<b>SITE-WISE DATA &amp; ANALYSIS</b>					
<b>Site No.:</b> 24	<b>Location:</b> Tilonia	<b>Climatic Zone:</b> Hot & Dry			
<b>Module No. :</b> B	<b>Type:</b> Multi Crystalline Silicon	<b>Power Rating:</b> 45 Wp	<b>Age:</b> 13 years		
	<b>Encapsulant</b>	<b>Backsheet</b>	<b>Metallization</b>	<b>Junction Box</b>	<b>Frame</b>
<b>Degradation Present</b>	Yes	No	Yes	Yes	Yes
<b>Details</b>	Light Discoloration, Delamination between cells	Like New	Dark Corrosion	loose/brittle	Minor damage & corrosion
<b>Module Soiling:</b>	Heavily soiled	<b>Shaded Area:</b>	25 – 75%	<b>Maintenance:</b>	Preventive <b>End Use:</b> light, fan
<b>Electrical Performance:</b>					
Degradation in Pmax (% per year *)	1.33				
Degradation in Isc (% per year *)	0.13				
Degradation in Voc (% per year *)	0.33				
* Based on I-V Curve correction using assumed values for various coefficients (alpha = 0.12% per C, beta =-0.2% per C, Rs=0 & k=0) and assuming linear rate of degradation with time.					
<b>Key Observations:</b>					
<ul style="list-style-type: none"> <li>• Light discoloration and delamination in 1 cell</li> <li>• Corrosion in the string interconnects</li> <li>• Tilt angle of Module is 16 deg. whereas Latitude is 26 deg.</li> <li>• (Non-optimum tilt)</li> </ul>					
<b>Recommendations:</b>					
Modules should be cleaned at least once a week since dust on the modules can reduce the power generation. The tilt angle should be adjusted close to the latitude tilt to maximize the annual energy generation.					
<b>Multi crystalline silicon module with glass at both top and bottom</b>		<b>Corrosion in String Interconnects</b>		<b>Delamination (bubbles) in a solar cell</b>	
					



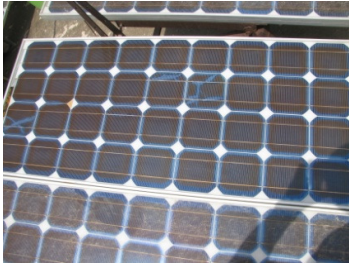
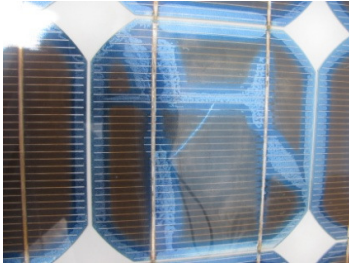

## ALL INDIA SURVEY OF PV MODULE DEGRADATION: 2013

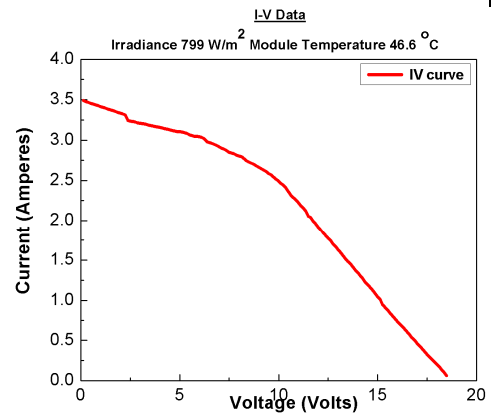

<b>SITE-WISE DATA &amp; ANALYSIS</b>					
<b>Site No.:</b>	24	<b>Location:</b>	Tilonia	<b>Climatic Zone:</b>	Hot & Dry
<b>Module No. :</b>	C	<b>Type:</b>	Multi Crystalline Silicon	<b>Power Rating:</b>	75 Wp
				<b>Age:</b>	13 years
	<b>Encapsulant</b>	<b>Backsheet</b>	<b>Metallization</b>	<b>Junction Box</b>	<b>Frame</b>
<b>Degradation Present</b>	Yes	No	Yes	No	Yes
<b>Details</b>	Dark Discoloration, Delamination from edges	Like New	Dark Corrosion	Intact & Good Seal	Minor damage & corrosion
<b>Module Soiling:</b>	Heavily soiled	<b>Shaded Area:</b>	25 – 75%	<b>Maintenance:</b>	Preventive
				<b>End Use:</b>	light, fan
<b>Electrical Performance:</b>					
Degradation in Pmax (% per year *)	3.95				
Degradation in Isc (% per year *)	1.15				
Degradation in Voc (% per year *)	0.08				
* Based on I-V Curve correction using assumed values for various coefficients (alpha = 0.12% per C, beta = -0.2% per C, Rs=0 & k=0) and assuming linear rate of degradation with time.					
<b>Key Observations:</b>					
<ul style="list-style-type: none"> <li>Dark discoloration in all of the solar cells</li> <li>Delamination in most of the cells along the cell periphery</li> <li>Minor corrosion in the output terminals</li> <li>Tilt angle of Module is 16 deg. whereas Latitude is 26 deg.</li> <li>(Non-optimum tilt)</li> </ul>					
<b>Recommendations:</b>					
Modules should be cleaned at least once a week since dust on the modules can reduce the power generation.					
<b>Dark discoloration in all solar cells</b>		<b>Delamination in a Solar cell</b>		<b>Corrosion in output terminals</b>	
					

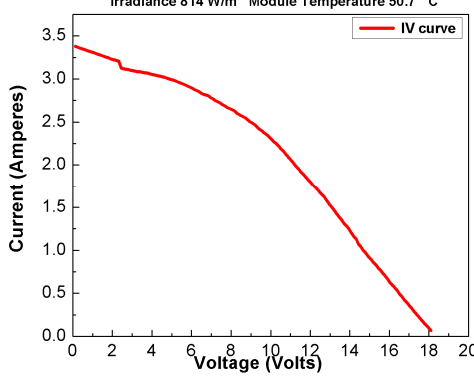

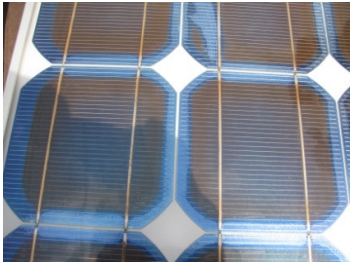
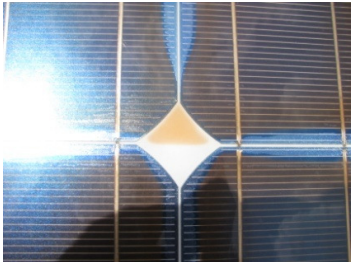

## ALL INDIA SURVEY OF PV MODULE DEGRADATION: 2013

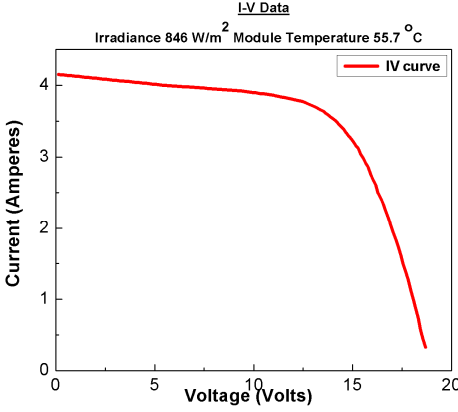
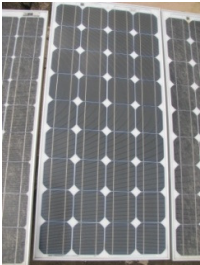
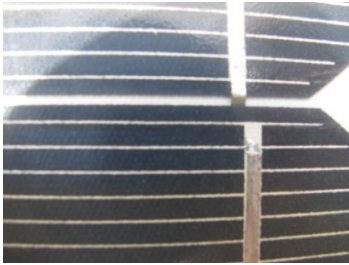
<b>SITE-WISE DATA &amp; ANALYSIS</b>					
<b>Site No.:</b> 24	<b>Location:</b> Tilonia	<b>Climatic Zone:</b> Hot & Dry			
<b>Module No. :</b> D	<b>Type:</b> Multi Crystalline Silicon	<b>Power Rating:</b> 75 Wp	<b>Age:</b> 13 years		
<b>Degradation Present</b>	<b>Encapsulant</b>	<b>Backsheet</b>	<b>Metallization</b>	<b>Junction Box</b>	<b>Frame</b>
	Yes	No	Yes	No	Yes
<b>Details</b>	Dark Discoloration, Delamination from edges	Like New	Dark Corrosion	Intact & Good Seal	Minor damage & corrosion
<b>Module Soiling:</b>	Heavily soiled	<b>Shaded Area:</b>	25 – 75%	<b>Maintenance:</b>	Preventive
		<b>End Use:</b>	light, fan		
<b>Electrical Performance:</b>					
Degradation in Pmax (% per year *)	4.24				
Degradation in Isc (% per year *)	1.50				
Degradation in Voc (% per year *)	0.15				
* Based on I-V Curve correction using assumed values for various coefficients (alpha = 0.12% per C, beta =-0.2% per C, Rs=0 & k=0) and assuming linear rate of degradation with time.					
<b>Key Observations:</b>					
<ul style="list-style-type: none"> <li>Dark discoloration in all solar cells</li> <li>Delamination along the periphery of most of the solar cells</li> <li>Major corrosion at some portions of the busbars and cell interconnects.</li> <li>Tilt angle of Module is close to the Latitude of the site.</li> </ul>					
<div style="display: flex; align-items: flex-start;"> <div style="flex: 1;"> <p style="text-align: center; margin-bottom: 5px;"><b>I-V Data</b></p> <p style="text-align: center; margin-bottom: 5px;">Irradiance 814 W/m<sup>2</sup> Module Temperature 50.7 °C</p>  </div> </div>					
<b>Recommendations:</b>					
Modules should be cleaned at least once a week since dust on the modules can reduce the power generation.					
<b>Dark discoloration in all solar cells</b>		<b>Delamination along the periphery of the solar cells</b>		<b>Discoloration just above the junction box area</b>	
					

## ALL INDIA SURVEY OF PV MODULE DEGRADATION: 2013

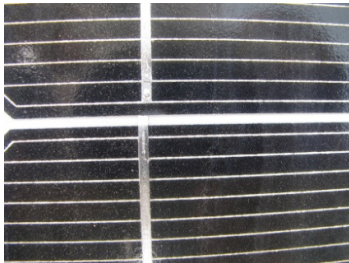

<b>SITE-WISE DATA &amp; ANALYSIS</b>					
<b>Site No.:</b>	24	<b>Location:</b>	Tilonia	<b>Climatic Zone:</b>	Hot & Dry
<b>Module No. :</b>	E	<b>Type:</b>	Mono Crystalline Silicon	<b>Power Rating:</b>	75 Wp <b>Age:</b> 13 years
	<b>Encapsulant</b>	<b>Backsheet</b>	<b>Metallization</b>	<b>Junction Box</b>	<b>Frame</b>
<b>Degradation Present</b>	Yes	No	Yes	No	Yes
<b>Details</b>	Light Discoloration, No Delamination	Like New	Corrosion	Intact & Good Seal	Minor damage & corrosion
<b>Module Soiling:</b>	Heavily soiled	<b>Shaded Area:</b>	25 – 75%	<b>Maintenance:</b>	Preventive <b>End Use:</b> light, fan
<b>Electrical Performance:</b>					
Degradation in Pmax (% per year *)	1.08				
Degradation in Isc (% per year *)	0.36				
Degradation in Voc (% per year *)	0.19				
* Based on I-V Curve correction using assumed values for various coefficients (alpha = 0.12% per C, beta = -0.2% per C, Rs=0 & k=0) and assuming linear rate of degradation with time.					
<b>Key Observations:</b>					
<ul style="list-style-type: none"> <li>Light discoloration in all cells</li> <li>Discoloration in the cell interconnects</li> <li>Output terminals are free from corrosion but lightly soiled.</li> <li>Tilt angle of Module is close to the Latitude of the site.</li> </ul>					
					
<b>Recommendations:</b>					
Modules should be cleaned at least once a week since dust on the modules can reduce the power generation.					
<b>Light Discoloration in all cells</b>		<b>corrosion in metallization</b>		<b>Output terminals are soiled but free from corrosion</b>	
					

## ALL INDIA SURVEY OF PV MODULE DEGRADATION: 2013

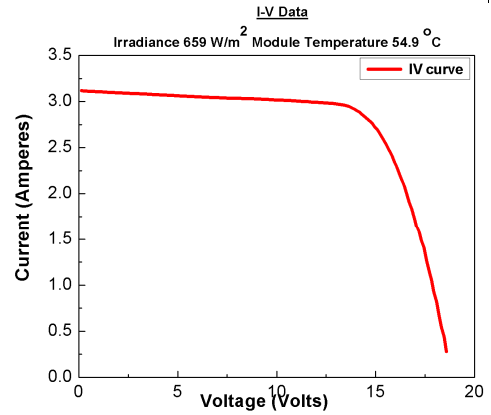
<b>SITE-WISE DATA &amp; ANALYSIS</b>					
<b>Site No.:</b> 24	<b>Location:</b> Tilonia	<b>Climatic Zone:</b> Hot & Dry			
<b>Module No. :</b> F	<b>Type:</b> Mono Crystalline Silicon	<b>Power Rating:</b> 80 Wp	<b>Age:</b> 6 years		
	<b>Encapsulant</b>	<b>Backsheet</b>	<b>Metallization</b>	<b>Junction Box</b>	<b>Frame</b>
<b>Degradation Present</b>	Yes	No	Yes	No	Yes
<b>Details</b>	Light Discoloration, Delamination	Like New	Light Corrosion	Intact & Good Seal	Minor damage & corrosion
<b>Module Soiling:</b>	Heavily soiled	<b>Shaded Area:</b>	25 – 75%	<b>Maintenance:</b>	Preventive
		<b>End Use:</b>	light, fan		
<b>Electrical Performance:</b>					
Degradation in Pmax (% per year *)	2.18				
Degradation in Isc (% per year *)	1.36				
Degradation in Voc (% per year *)	0.43				
* Based on I-V Curve correction using assumed values for various coefficients (alpha = 0.12% per C, beta =-0.2% per C, Rs=0 & k=0) and assuming linear rate of degradation with time.					
<b>Key Observations:</b>					
<ul style="list-style-type: none"> <li>Light discoloration and delamination in 1 cell</li> <li>Discoloration in the Metallization (fingers)</li> <li>Corrosion in output terminals</li> <li>Tilt angle of Module is close to Latitude angle of site</li> </ul>					
<b>Recommendations:</b>					
Modules should be cleaned at least once a week since dust on the modules can reduce the power generation.					
<b>Light Discoloration</b>		<b>Front Glass has become grainy (coarse to touch)</b>		<b>Corrosion in output terminals</b>	
					



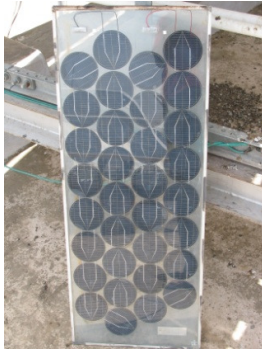

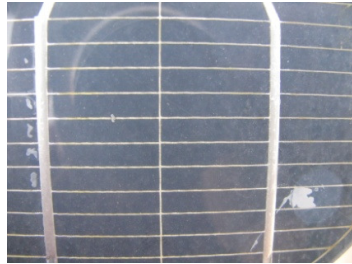
## ALL INDIA SURVEY OF PV MODULE DEGRADATION: 2013

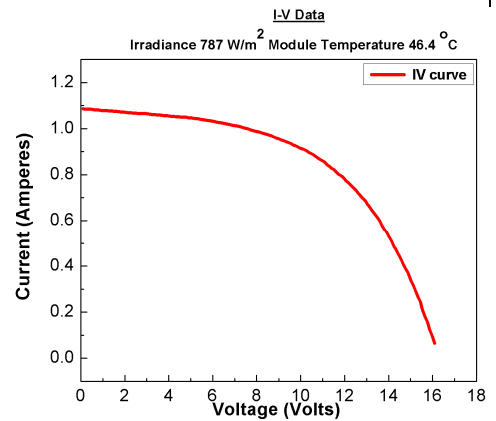
<b>SITE-WISE DATA &amp; ANALYSIS</b>					
<b>Site No.:</b>	25	<b>Location:</b>	Tilonia	<b>Climatic Zone:</b>	Hot & Dry
<b>Module No. :</b>	A	<b>Type:</b>	Mono Crystalline Silicon	<b>Power Rating:</b>	32 Wp <b>Age:</b> 28 years
	<b>Encapsulant</b>	<b>Backsheet</b>	<b>Metallization</b>	<b>Junction Box</b>	<b>Frame</b>
<b>Degradation Present</b>	Yes	NA	Yes	NA	Yes
<b>Details</b>	Light Discoloration, Delamination between cells	NA	Light Corrosion	NA	Minor damage & corrosion
<b>Module Soiling:</b>	Heavily soiled	<b>Shaded Area:</b>	25 – 75%	<b>Maintenance:</b>	Preventive <b>End Use:</b> light, fan
<b>Electrical Performance:</b>					
Degradation in Pmax (% per year *)	2.06				
Degradation in Isc (% per year *)	1.63				
Degradation in Voc (% per year *)	0.55				
* Based on I-V Curve correction using assumed values for various coefficients (alpha = 0.12% per C, beta = -0.2% per C, Rs=0 & k=0) and assuming linear rate of degradation with time.					
<b>Key Observations:</b>					
<ul style="list-style-type: none"> <li>Very light discoloration in some cells</li> <li>Delamination in a few cells</li> <li>Delamination (air pockets or void) at some positions between solar cells.</li> <li>Minor corrosion in the fingers in some cells</li> <li>Tilt angle of Module is close to the Latitude angle.</li> </ul>					
<b>Recommendations:</b>					
Modules should be cleaned at least once a week since dust on the modules can reduce the power generation.					
<b>Mono Crystalline silicon module with Glass on top (and bottom)</b>		<b>Back side of the Module</b>		<b>Delamination</b>	
					



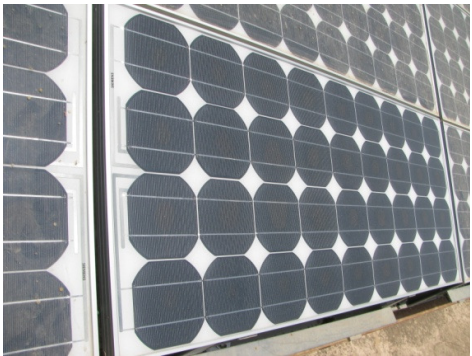
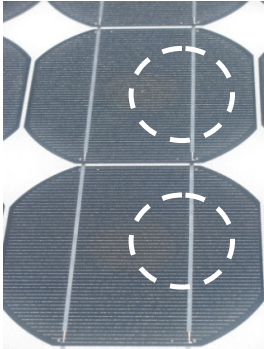

ALL INDIA SURVEY OF PV MODULE DEGRADATION: 2013

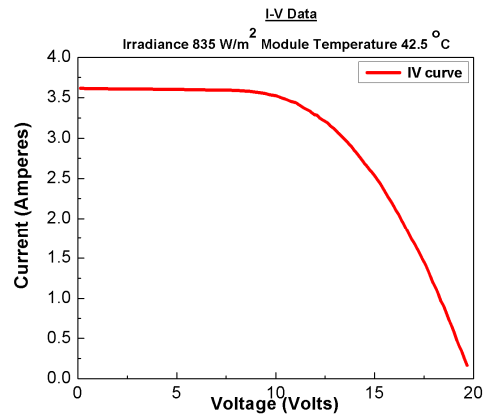
SITE-WISE DATA & ANALYSIS					
<b>Site No.:</b> 25	<b>Location:</b> Tilonia	<b>Climatic Zone:</b> Hot & Dry			
<b>Module No. :</b> B	<b>Type:</b> Mono Crystalline Silicon	<b>Power Rating:</b> 75 Wp	<b>Age:</b> 13 years		
	<b>Encapsulant</b>	<b>Backsheet</b>	<b>Metallization</b>	<b>Junction Box</b>	<b>Frame</b>
<b>Degradation Present</b>	Yes	No	No	No	No
<b>Details</b>	Light Discoloration, No Delamination	Like New	Like New	Intact & Good Seal	Like New
<b>Module Soiling:</b>	Heavily soiled	<b>Shaded Area:</b>	25 – 75%	<b>Maintenance:</b>	Preventive <b>End Use:</b> light, fan
<b>Electrical Performance:</b>					
Degradation in Pmax (% per year *)	2.33				
Degradation in Isc (% per year *)	0.85				
Degradation in Voc (% per year *)	0.12				
* Based on I-V Curve correction using assumed values for various coefficients (alpha = 0.12% per C, beta =-0.2% per C, Rs=0 & k=0) and assuming linear rate of degradation with time.					
<b>Key Observations:</b>					
<ul style="list-style-type: none"> <li>• Light discoloration in the middle of each cell</li> <li>• No delamination in any of the cells</li> <li>• No corrosion in the metallization and output terminals</li> <li>• Tilt angle of Module is 18 deg. whereas Latitude is 9 deg.</li> <li>• (Non-optimum tilt)</li> <li>• Chalking (white powder) from the backsheet</li> </ul>					
<b>Recommendations:</b>					
Modules should be cleaned at least once a week since dust on the modules can reduce the power generation.					
<b>Module is free from delamination</b>		<b>Light discoloration in centre of each solar cell</b>		<b>Chalking (white powder) from backsheet</b>	
					



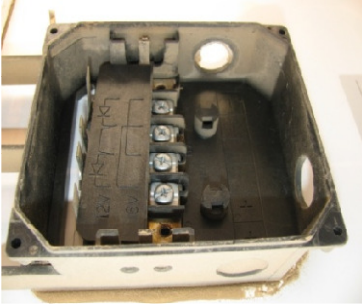

## ALL INDIA SURVEY OF PV MODULE DEGRADATION: 2013

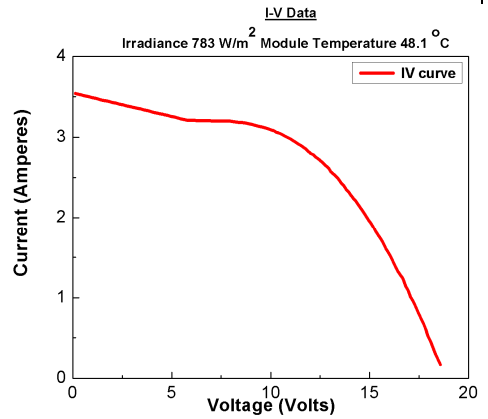

<b>SITE-WISE DATA &amp; ANALYSIS</b>					
<b>Site No.:</b> 25	<b>Location:</b> Tilonia	<b>Climatic Zone:</b> Hot & Dry			
<b>Module No. :</b> C	<b>Type:</b> Mono Crystalline Silicon	<b>Power Rating:</b> 75 Wp	<b>Age:</b> 13 years		
	<b>Encapsulant</b>	<b>Backsheet</b>	<b>Metallization</b>	<b>Junction Box</b>	<b>Frame</b>
<b>Degradation Present</b>	No	No	No	No	No
<b>Details</b>	No Discoloration, No Delamination	Like New	Like New	Intact & Good Seal	Like New
<b>Module Soiling:</b>	Heavily soiled	<b>Shaded Area:</b>	25 – 75%	<b>Maintenance:</b>	Preventive
		<b>End Use:</b>	light, fan		
<b>Electrical Performance:</b>					
Degradation in Pmax (% per year *)	2.64				
Degradation in Isc (% per year *)	0.58				
Degradation in Voc (% per year *)	0.19				
* Based on I-V Curve correction using assumed values for various coefficients (alpha = 0.12% per C, beta = -0.2% per C, Rs=0 & k=0) and assuming linear rate of degradation with time.					
<b>Key Observations:</b>					
<ul style="list-style-type: none"> <li>No discoloration in the middle of each cell</li> <li>No delamination in any of the cells</li> <li>No corrosion in the metallization and output terminals</li> <li>Tilt angle of Module is 18 deg. whereas Latitude is 9 deg.</li> <li>(Non-optimum tilt)</li> </ul>					
<b>Recommendations:</b>					
Modules should be cleaned at least once a week since dust on the modules can reduce the power generation.					
<b>No Discoloration</b>		<b>No Discoloration in Metallization</b>		<b>Junction box intact and good seal</b>	
					

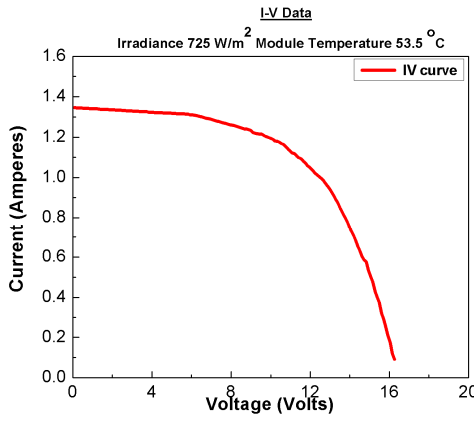
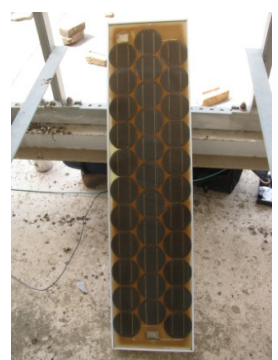

## ALL INDIA SURVEY OF PV MODULE DEGRADATION: 2013

<b>SITE-WISE DATA &amp; ANALYSIS</b>					
<b>Site No.:</b> 25	<b>Location:</b> Tilonia	<b>Climatic Zone:</b> Hot & Dry			
<b>Module No. :</b> D	<b>Type:</b> Multi Crystalline Silicon	<b>Power Rating:</b> 33 Wp	<b>Age:</b> 27 years		
	<b>Encapsulant</b>	<b>Backsheet</b>	<b>Metallization</b>	<b>Junction Box</b>	<b>Frame</b>
<b>Degradation Present</b>	Yes	No	Yes	NA	No
<b>Details</b>	Dark Discoloration, Delamination from cell edges	Like New	Light Corrosion	NA	Like New
<b>Module Soiling:</b>	Heavily soiled	<b>Shaded Area:</b> 25 – 75%	<b>Maintenance:</b> Preventive	<b>End Use:</b> light, fan	
<b>Electrical Performance:</b>					
Degradation in Pmax (% per year *)	1.44				
Degradation in Isc (% per year *)	0.78				
Degradation in Voc (% per year *)	0.37				
* Based on I-V Curve correction using assumed values for various coefficients (alpha = 0.12% per C, beta = -0.2% per C, Rs=0 & k=0) and assuming linear rate of degradation with time.					
<b>Key Observations:</b>					
<ul style="list-style-type: none"> <li>• Dark discoloration not only above the solar cells but also in between the solar cells</li> <li>• Discoloration in the Metallization (fingers)</li> <li>• Puncture in the backsheet just below a solar cell</li> </ul>					
					
<b>Recommendations:</b>					
Modules should be cleaned at least once a week since dust on the modules can reduce the power generation. Module should be handled with care during installation so as to prevent any scratches or puncture in the modules.					
<b>Dark discoloration over almost the entire module</b>		<b>Corrosion in Metallization</b>		<b>Puncture/scratch in the backsheet, just below a solar cell</b>	
					

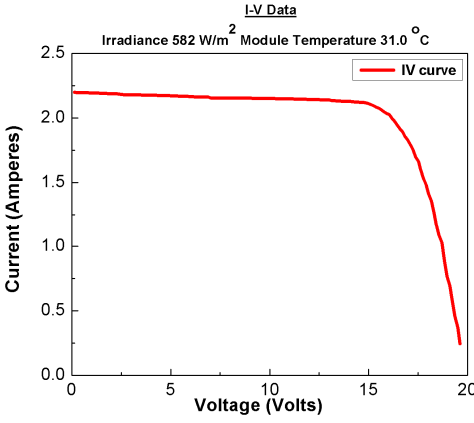
## ALL INDIA SURVEY OF PV MODULE DEGRADATION: 2013

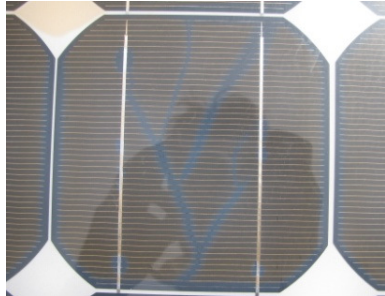
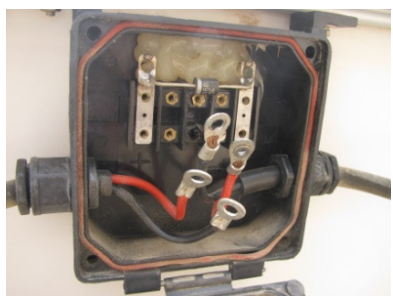
<b>SITE-WISE DATA &amp; ANALYSIS</b>					
<b>Site No.:</b>	26	<b>Location:</b>	Hanle	<b>Climatic Zone:</b>	Cold
<b>Module No. :</b>	A	<b>Type:</b>	Mono Crystalline Silicon	<b>Power Rating:</b>	75 Wp <b>Age:</b> 15 years
	<b>Encapsulant</b>	<b>Backsheet</b>	<b>Metallization</b>	<b>Junction Box</b>	<b>Frame</b>
<b>Degradation Present</b>	Yes	No	Yes	No	No
<b>Details</b>	Dark Discoloration, Delamination	Like New	Light Corrosion	Intact & Good Seal	Like New
<b>Module Soiling:</b>	Lightly Soiled	<b>Shaded Area:</b>	0 %	<b>Maintenance:</b>	Preventive <b>End Use:</b> Motor of telescope
<b>Electrical Performance:</b>					
Degradation in Pmax (% per year *)	0.15				
Degradation in Isc (% per year *)	0.78				
Degradation in Voc (% per year *)	-0.58				
* Based on I-V Curve correction using assumed values for various coefficients (alpha = 0.12% per C, beta = -0.2% per C, Rs=0 & k=0) and assuming linear rate of degradation with time.					
<b>Key Observations:</b>					
<ul style="list-style-type: none"> <li>Dark discoloration in all solar cells in the module</li> <li>Cracks in some solar cells (made visible by photo-oxidative bleaching)</li> <li>No corrosion in the output terminals</li> <li>Tilt angle of Module is equal to the latitude of the place</li> </ul>					
<div style="display: flex; align-items: center;"> <div style="flex: 1;"> <p style="font-size: small; margin: 0;">I-V Data Irradiance 582 W/m<sup>2</sup>    Module Temperature 31.0 °C</p>  </div> </div>					
<b>Recommendations:</b>					
Modules should be cleaned at least once a week since dust on the modules can reduce the power generation. Module should be handled with care during installation so as to prevent any scratches or puncture in the modules. Module junction boxes should be properly covered to prevent moisture ingress (which can corrode the output terminals) and the cables should be regularly checked for any breakage, animal bites etc.					
<b>Module having discoloration in all solar cells</b>		<b>Crack in the solar cell made visible by the photo-oxidation process</b>		<b>Output terminals are intact</b>	
					

## ALL INDIA SURVEY OF PV MODULE DEGRADATION: 2013

<b>SITE-WISE DATA &amp; ANALYSIS</b>					
<b>Site No.:</b> 26	<b>Location:</b> Hanle	<b>Climatic Zone:</b> Cold			
<b>Module No. :</b> B	<b>Type:</b> Mono Crystalline Silicon	<b>Power Rating:</b> 75 Wp	<b>Age:</b> 15 years		
	<b>Encapsulant</b>	<b>Backsheet</b>	<b>Metallization</b>	<b>Junction Box</b>	<b>Frame</b>
<b>Degradation Present</b>	Yes	No	Yes	No	No
<b>Details</b>	Dark Discoloration, Delamination	Like New	Light Corrosion	Intact & Good Seal	Like New
<b>Module Soiling:</b>	Lightly Soiled	<b>Shaded Area:</b>	0 %	<b>Maintenance:</b>	Preventive
		<b>End Use:</b>	Motor of telescope		
<b>Electrical Performance:</b>					
Degradation in Pmax (% per year *)	1.12				
Degradation in Isc (% per year *)	0.82				
Degradation in Voc (% per year *)	0.15				
* Based on I-V Curve correction using assumed values for various coefficients (alpha = 0.12% per C, beta = -0.2% per C, Rs=0 & k=0) and assuming linear rate of degradation with time.					
<b>Key Observations:</b>					
<ul style="list-style-type: none"> <li>• Dark discoloration in all cells but delamination in just 1 cell</li> <li>• Minor corrosion in the metallization</li> <li>• Tilt angle of Module is equal to the latitude of the place.</li> </ul>					
<div style="display: flex; align-items: flex-start;"> <div style="flex: 1;"> <p style="text-align: center; font-size: small;">I-V Data Irradiance 871 W/m<sup>2</sup> Module Temperature 45.8 °C</p> </div> </div>					
<b>Recommendations:</b>					
Modules should be cleaned at least once a week since dust on the modules can reduce the power generation. Module should be handled with care during installation so as to prevent any scratches or puncture in the modules. Module junction boxes should be properly covered to prevent moisture ingress (which can corrode the output terminals) and the cables should be regularly checked for any breakage, animal bites etc.					
<b>Dark discoloration in all solar cells</b>		<b>Discoloration in encapsulant between 2 cells</b>		<b>Output terminals are intact</b>	

## ALL INDIA SURVEY OF PV MODULE DEGRADATION: 2013

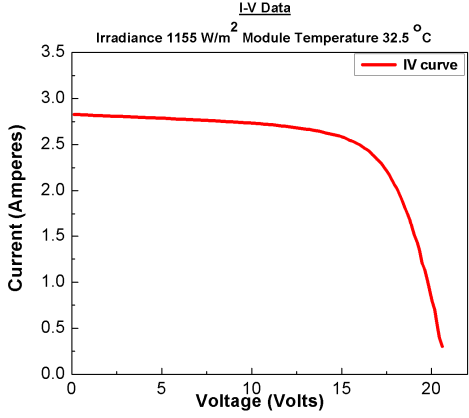
<b>SITE-WISE DATA &amp; ANALYSIS</b>					
<b>Site No.:</b> 26	<b>Location:</b> Hanle	<b>Climatic Zone:</b> Cold			
<b>Module No. :</b> C	<b>Type:</b> Mono Crystalline Silicon	<b>Power Rating:</b> 35 Wp	<b>Age:</b> 15 years		
	<b>Encapsulant</b>	<b>Backsheet</b>	<b>Metallization</b>	<b>Junction Box</b>	<b>Frame</b>
<b>Degradation Present</b>	No	Yes	Yes	No	No
<b>Details</b>	No Discoloration, No Delamination	Puncture	Light Corrosion	Intact & Good Seal	Like new
<b>Module Soiling:</b>	Lightly Soiled	<b>Shaded Area:</b>	0 %	<b>Maintenance:</b>	Preventive
		<b>End Use:</b>	Motor of telescope		
<b>Electrical Performance:</b>					
Degradation in Pmax (% per year *)	0.12				
Degradation in Isc (% per year *)	0.44				
Degradation in Voc (% per year *)	0.04				
* Based on I-V Curve correction using assumed values for various coefficients (alpha = 0.12% per C, beta = -0.2% per C, Rs=0 & k=0) and assuming linear rate of degradation with time.					
<b>Key Observations:</b>					
<ul style="list-style-type: none"> <li>No discoloration and delamination.</li> <li>Crack in few cells.</li> <li>Heavy corrosion in junction box terminals.</li> </ul>					
<div style="display: flex; align-items: center; justify-content: flex-end;"> <div style="margin-right: 20px;"> <p style="font-size: small; margin: 0;">I-V Data</p> <p style="font-size: x-small; margin: 0;">Irradiance 1155 W/m<sup>2</sup> Module Temperature 32.5 °C</p>  </div> </div>					
<b>Recommendations:</b>					
Modules should be cleaned at least once a week since dust on the modules can reduce the power generation. Junction box should be sealed to avoid corrosion of terminals.					
<b>No Discoloration and Delamination</b>		<b>Cracks in cell</b>		<b>Corrosion in junction box and terminals</b>	
